

Instruction Manual

Stainless Steel and Hygienic Stainless Steel Sensors for Washdown and Chemical Compatibility

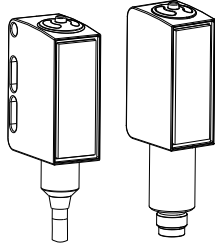

- QM26: Washdown rated with convenient 25.4 mm (1 in) mounting spacing and 3 mm (0.125 in) mounting hardware
- QMH26: Hygienic shape for superior cleaning performance
- Made from FDA compliant materials for worry-free use in food and pharmaceutical applications
- Chemically resistant, non-toxic 316L stainless steel housing
- Acrylic optical window with coating for resistance to hydrogen peroxide and alcohol
- IP69K rated for use in harsh 1500 psi washdown environments at 80° C (176° F)
- Withstands environmental temperature cycling from -30° to +60° C (-22° to +140° F)
- Sealed housing and smooth joints minimize cleaning time and reduce bacterial accumulation
- Sensor marking is chemically etched into the housing for long-lasting identification and to eliminate food contamination
- Push buttons and light pipes are over-molded to reduce crevices and provide excellent cleaning and sealing results
- High performance coaxial polarized retroreflective models for clear or transparent bottle and film detection
- Excellent background suppression performance with advanced ambient light suppression
- Bright, visible red light spot on adjustable background suppression models makes alignment easy
- Models have a hygienic design for easy cleaning and sanitizing



WARNING: Not To Be Used for Personnel **Protection**

Never use this device as a sensing device for personnel **protection**. Doing so could lead to serious injury or death. This device does not include the self-checking redundant circuitry necessary to allow its use in personnel safety applications. A sensor failure or malfunction can cause either an energized or de-energized sensor output condition.

QM26 Models

Stainless Steel Sensors for Washdown and Chemical Compatibility

Model	Mode	Range	Output	Connector	
QM26E-5M	Emitter	8.5 m (27.8 ft)	NA	5 m (16.25 ft) cable, 4 wire	
QM26EQ5				200 mm (7.5 in) PVC pigtail, M12 Euro QD connector, 4-pin	
QM26VNR-5M	Receiver		Complementary NPN	5 m (16.25 ft) cable, 4 wire	
QM26VNRQ5				200 mm (7.5 in) PVC pigtail, M12 Euro QD connector, 4-pin	
QM26VPR-5M			Complementary PNP	5 m (16.25 ft) cable, 4 wire	
QM26VPRQ5				200 mm (7.5 in) PVC pigtail, M12 Euro QD connector, 4-pin	
QM26VNLP-5M	Polarized Retroreflective	3 m (9.8 ft) with BRT-60X40C	Complementary NPN	5 m (16.25 ft) cable, 4 wire	
QM26VNLPQ5				200 mm (7.5 in) PVC pigtail, M12 Euro QD connector, 4-pin	
QM26VPLP-5M			Complementary PNP	5 m (16.25 ft) cable, 4 wire	
QM26VPLPQ5				200 mm (7.5 in) PVC pigtail, M12 Euro QD connector, 4-pin	
QM26ENX LPC-5M	Expert™ Coaxial Polarized Retroreflective		2.6 m (8.5 ft) with BRT-60X40C	NPN	5 m (16.25 ft) cable, 4 wire
QM26ENX LPCQ5					200 mm (7.5 in) PVC pigtail, M12 Euro QD connector, 4-pin
QM26EPX LPC-5M				PNP	5 m (16.25 ft) cable, 4 wire
QM26EPX LPCQ5					200 mm (7.5 in) PVC pigtail, M12 Euro QD connector, 4-pin



Model	Mode	Range	Output	Connector
QM26VNAF400-5M	Adjustable Field Background Suppression	5 to 400 mm (0.2 in to 15.7 in)	Complementary NPN	5 m (16.25 ft) cable, 4 wire
QM26VNAF400Q5				200 mm (7.5 in) PVC pigtail, M12 Euro QD connector, 4-pin
QM26VPAF400-5M			Complementary PNP	5 m (16.25 ft) cable, 4 wire
QM26VPAF400Q5				200 mm (7.5 in) PVC pigtail, M12 Euro QD connector, 4-pin
QM26VNAF200-5M	Adjustable Field Background Suppression (small light spot) And	5 to 200 mm (0.2 in to 7.85 in)	Complementary NPN	5 m (16.25 ft) cable, 4 wire
QM26VNAF200Q5				200 mm (7.5 in) PVC pigtail, M12 Euro QD connector, 4-pin
QM26VPAF200-5M			Complementary PNP	5 m (16.25 ft) cable, 4 wire
QM26VPAF200Q5				200 mm (7.5 in) PVC pigtail, M12 Euro QD connector, 4-pin

QMH26 Models

Hygienic Stainless Steel Sensors for Washdown and Chemical Compatibility

Model	Mode	Range	Output	Connector
QMH26VNLP-5M	Polarized Retroreflective	3m (9.8 ft) with BRT-60X40C	Complementary NPN	5 m (16.25 ft) cable, 4 wire
QMH26VNLPQ7				M8 Pico QD connector, 4-pin
QMH26VPLP-5M			Complementary PNP	5 m (16.25 ft) cable, 4 wire
QMH26VPLPQ7				M8 Pico QD connector, 4-pin
QMH26ENXLPC-5M	<i>Expert™</i> Coaxial Polarized Retroreflective	2.6 m (8.5 ft) with BRT-60X40C	NPN	5 m (16.25 ft) cable, 4 wire
QMH26ENXLPCQ7				M8 Pico QD connector, 4-pin
QMH26EPXLPC-5M			PNP	5 m (16.25 ft) cable, 4 wire
QMH26EPXLPCQ7				M8 Pico QD connector, 4-pin
QMH26VNAF400-5M	Adjustable Field Background Suppression	5 to 400 mm (0.2 in to 15.7 in)	Complementary NPN	5 m (16.25 ft) cable, 4 wire
QMH26VNAF400Q7				M8 Pico QD connector, 4-pin
QMH26VPAF400-5M			Complementary PNP	5 m (16.25 ft) cable, 4 wire
QMH26VPAF400Q7				M8 Pico QD connector, 4-pin
QMH26VNAF200-5M	Adjustable Field Background Suppression (small light spot)	5 to 200 mm (0.2 in to 7.85 in)	Complementary NPN	5 m (16.25 ft) cable, 4 wire
QMH26VNAF200Q7				M8 Pico QD connector, 4-pin
QMH26VPAF200-5M			Complementary PNP	5 m (16.25 ft) cable, 4 wire
QMH26VPAF200Q7				M8 Pico QD connector, 4-pin

Overview

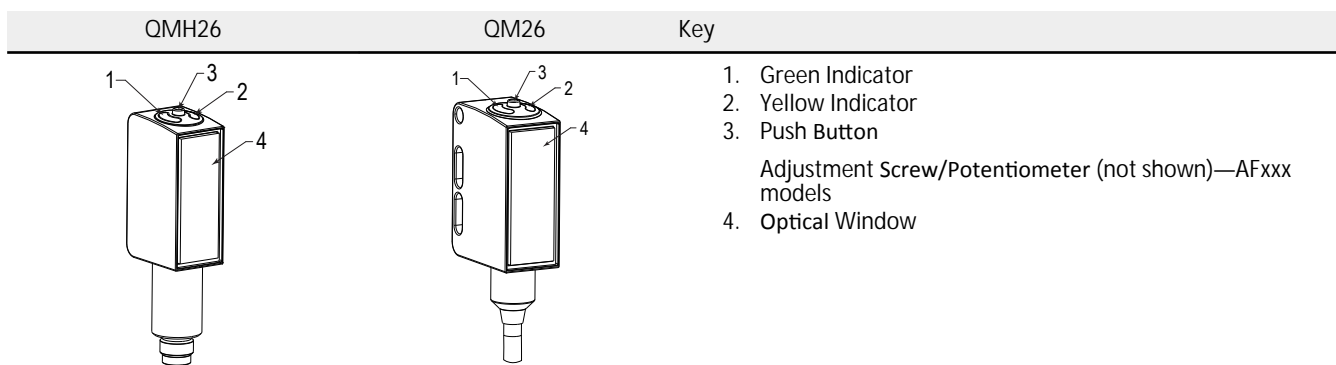

Sensor Installation

Install the sensor so that the object to be detected moves horizontally to the sensor.

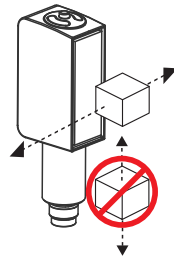

Wiring Diagrams

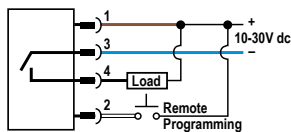

Expert™ NPN

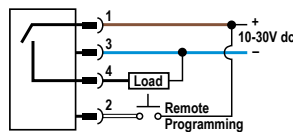

Expert™ PNP

Wiring Key
 1 = Brown
 2 = White
 3 = Blue
 4 = Black

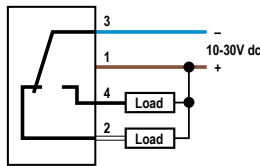

NPN

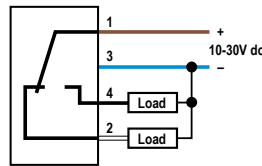

PNP

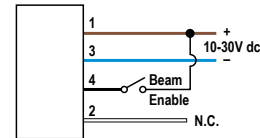

QM26—Emitters

Sensor Configuration

- Adjustable field background suppression models (AFxxx models) have an 8-turn adjustment screw (potentiometer) to set the background suppression distance.
- Expert™ coaxial polarized retroreflective models (XLPC models) are configurable using either the sealed push button or the remote input wire.
- Two-lens polarized retroreflective models (LP models) and opposed mode models require no user adjustments.

Sensor Setup - Background Suppression—AFxxx Models

Background Suppression Mode: Objects beyond the set cutoff distance will not be detected.

Background suppression mode can be used in most situations with varying object colors and positions or with varying background conditions.

To ensure reliable background suppression, a minimum separation distance between the object and the background is necessary. See [Figure 5](#) on page 10 to determine the minimum separation distance.

1. Mount the sensor with the darkest object at the longest application distance. The distance to the object must be less than shown in [Figure 5](#) on page 10 for your object color.
2. Turn the adjustment potentiometer counter-clockwise until the yellow indicator turns **off** (8 turns maximum).
3. Turn the adjustment potentiometer clockwise until the yellow indicator turns on.
4. Replace the darkest object with the brightest background at the closest application distance.
5. Turn the adjustment potentiometer clockwise, counting the revolutions, until the yellow indicator turns on.
6. Turn the adjustment potentiometer counter-clockwise half of the number of turns from step 5. This places the cutoff distance midway between the object and the background switchpoints (see [Figure 1](#) on page 4).

The sensor is ready for operation.

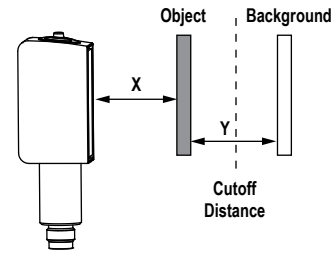

X: Distance to the Object

Y: Minimum Separation Between the Object and the Background

Figure 1.

Set the **cutoff** distance approximately midway between the farthest object and the closest background

Setup Example

An object with a reflectivity similar to black paper is set 100 mm (3.9 in) away from the AF200 sensor. A background with a reflectivity similar to white paper is set away from the sensor. According to [Figure 5](#) on page 10, the minimum separation distance between the object and the background is 24 mm (0.94 in). In this application, reliable detection is achieved when set up according to the procedure outlined in [Sensor Setup - Background Suppression—AFxxx Models](#) on page 3.

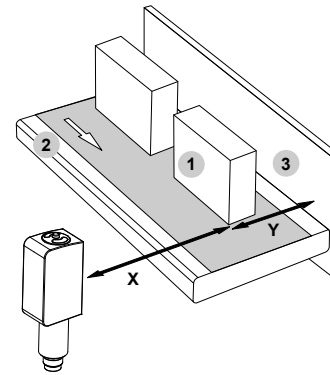

Figure 2. Background Suppression Mode Application Example

1. Object

2. Conveyor

3. Background

X: Distance to the Object = 100 mm (3.9 in)

Y: Minimum Separation Between the Object and the Background = 24 mm (0.94 in)

Remote Configuration—XLPC models

The remote input wire (pin 2/white wire) is used to lock the push button, select Light or Dark Operate, or perform the desired Light SET or Dark SET for the object. In contrast to other Banner Engineering sensors, the QM26 and QMH26 *Expert*™ coaxial polarized retroreflective sensors (XLPC models) use the duration between pull-high pulses on the remote input wire to both initiate the Light SET or Dark SET and to select the desired sensitivity simultaneously. See [Light SET for High Sensitivity](#) on page 5, [Light SET for Medium Sensitivity](#) on page 6, and [Dark SET for Maximum Operating Range](#) on page 7 for details.



Note: After the delay before startup has elapsed (≤ 300 ms), the remote input may be used.





Push Button Lockout—XLPC Models

The remote input wire (pin 2/white wire) can be used to disable the sensor push button on the XLPC models to prevent unauthorized adjustment to the sensor. Connect the remote input wire (pin 2/white wire) of the sensor to the +V dc terminal to disable configuration adjustments using the push button.

Push Button	Remote Input Wire	Result
Not available	Connect the remote input wire to +V dc for 4 ms or longer.	The push button is disabled (locked).
Not available	Disconnect the remote input wire from +V dc.	The push button is enabled (unlocked).

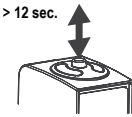
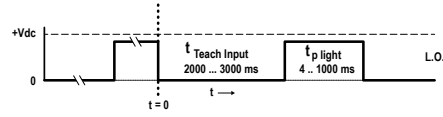
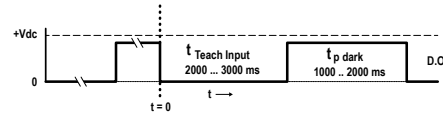
Select Light Operate/Dark Operate—XLPC models

Change the sensor operation to light operate or dark operate for the desired application. Use either the button or the remote input wire procedure to configure the sensor.

Push Button	Remote Input Wire	Result
<p>Press and hold the button for longer than 12 s.</p> <p>Continue pressing the button until the desired operation is selected, then release the button.</p> 	<p>Pulse the remote input wire to +V dc, then pull the remote input wire to ground for 2000 to 3000 ms.</p> <p>Light operate select: Pulse the remote input wire to +V dc for 4 to 1000 ms, then pull the remote input wire to ground.</p>  <p>Dark operate select: Pulse the remote input wire to +V dc for 1000 to 2000 ms, then pull the remote input wire to ground.</p> 	<p>Push button only: The green LED flashes.</p>  <p>Yellow LED ON = Light operate</p>  <p>Yellow LED OFF = Dark operate</p>  <p>The sensor is configured for the desired mode and is ready.</p>

Light SET—XLPC Models

A Light SET optimizes the sensor to provide reliable detection of various objects. For most applications, the factory default setting is appropriate. Perform the Light SET only if the desired object is not reliably detected. Stable mounting of both the sensor and the reflector is required for reliable detection.

- High sensitivity (11% offset)—suitable for highly transparent bottles, thin films, and foils. See [Light SET for High Sensitivity](#) on page 5.
- Medium sensitivity (18% offset)—suitable for standard bottle types and translucent objects. See [Light SET for Medium Sensitivity](#) on page 6.

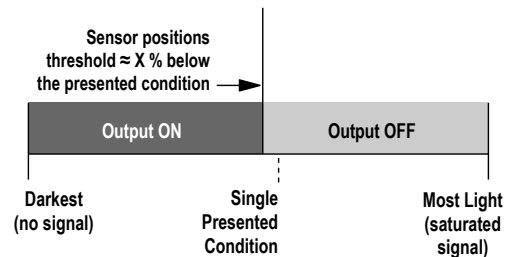
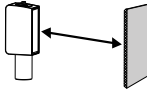
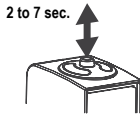
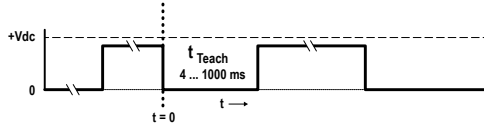
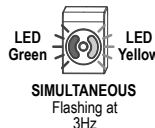

Figure 3. Light SET (Dark Operate Shown)



Light SET for High Sensitivity

Use High Sensitivity (11% sensitivity) for detecting highly transparent bottles, thin films, and foils with a thickness of more than 20 μm. Use either the button or the remote input wire procedure to configure the sensor.

Push Button	Remote Input Wire	Result
Clear the light path to the reflector.	Clear the light path to the reflector.	
Press the button for 2 to 7 seconds until the LEDs flash simultaneously, then release the button. 	Pulse the remote input wire to +V dc, then pull the remote input wire to ground for 4 to 1000 ms. Pulse the remote input wire to +V dc to complete the high sensitivity Light SET. 	Push button only: The green and yellow LEDs flash simultaneously.  SIMULTANEOUS Flashing at 3Hz The sensor is configured for High Sensitivity and is ready for use.

Light SET for Medium Sensitivity

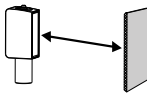
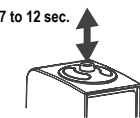
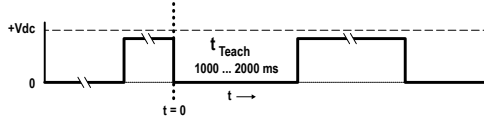
Use Medium Sensitivity (18% sensitivity) for detecting standard bottle types and translucent objects. Use either the button or the remote input wire procedure to configure the sensor.

Push Button	Remote Input Wire	Result
Clear the light path to the reflector.	Clear the light path to the reflector.	
Press the button for 7 to 12 seconds until the LEDs flash alternately, then release the button. 	Pulse the remote input wire to +V dc, then pull the remote input wire to ground for 1000 to 2000 ms. Pulse the remote input wire to +V dc to complete the medium sensitivity Light SET. 	Push button only: The green and yellow LEDs flash alternately.  ALTERNATELY Flashing at 3Hz The sensor is configured for Medium Sensitivity and is ready for use.

Dark SET—XLPC Models

Dark SET (maximum operating range) is the factory default setting and provides maximum sensing range, ease of alignment, and reliable detection of brown or green bottles and opaque objects.

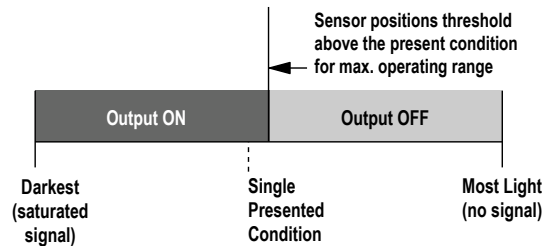
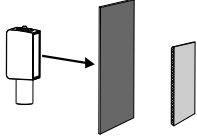
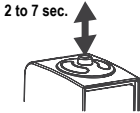
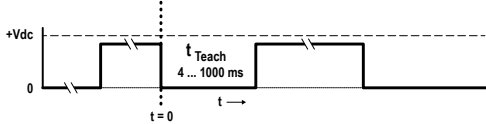
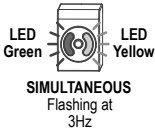
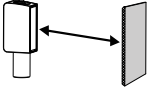

Figure 4. Dark SET (Dark Operate Shown)

Dark SET for Maximum **Operating** Range

Use either the **button** or the remote input wire procedure to configure the sensor.

Push Button	Remote Input Wire	Result
Block the light path to the reflector.	Block the light path to the reflector.	
Press the button for 2 to 7 seconds until the LEDs flash simultaneously, then release the button. 	Pulse the remote input wire to +V dc, then pull the remote input wire to ground for 4 to 1000 ms. Pulse the remote input wire to +V dc to complete the Dark SET. 	Push button only: The green and yellow LEDs flash simultaneously.  SIMULTANEOUS Flashing at 3Hz The sensor is configured for Dark SET (maximum operating range).
Clear the light path to the reflector.	Clear the light path to the reflector.	 The sensor is ready for use.

Specifications

Supply Voltage and Current

10 to 30 V dc (10% maximum ripple within specified limits); supply current (exclusive of load current) < 20 mA



Note: For UL applications: For use in class 2 circuits only.

Supply Protection Circuitry

Protected against reverse polarity and transient voltages

Output Configuration

XLPC models: Single PNP or NPN on pin 4 (black wire) with remote input on pin 2 (white wire)
All other models: Complementary PNP or NPN by model number

Delay Before Power-Up

< 300 ms

Output Rating

100 mA per output
Off-state leakage current for load = 1500 Ω:
NPN: < 200 μA
PNP: < 500 μA
ON-state **saturation** voltage: < 2 V at 100 mA

Output Protection Circuitry

Protected against false pulse at power up, and overload or short circuit of outputs

Emitter LED Wavelength

AF200 models: 660 nm
All other models: 620 nm

Required Overcurrent Protection



WARNING: Electrical connections must be made by qualified personnel in accordance with local and national electrical codes and regulations.

Overcurrent protection is required to be provided by end product application per the supplied table.

Overcurrent protection may be provided with external fusing or via Current Limiting, Class 2 Power Supply.

Supply wiring leads < 24 AWG shall not be spliced.

For additional product support, go to www.bannerengineering.com.

Supply Wiring (AWG)	Required Overcurrent Protection (Amps)
20	5.0
22	3.0
24	2.0
26	1.0
28	0.8
30	0.5

Output Response Time

500 μs

Repeatability

QM26—Opposed Models: 110 μs
All other models: 150 μs

Indicators

Green on: Power ON and sensor ready
Yellow on: Light sensed
XLPC models—Yellow **flashing**: Light sensed but marginal signal

Construction

Housing: 316L stainless steel
Optical Window: Coated acrylic (PMMA)
Indicator and buttons: TPV - PE

Connection

4-wire 5 m (16.25 ft) cable or 4-pin M12 Euro-style quick disconnect connector with 200 mm (7.5 in) PVC pigtail, depending on model
Banner recommends using the 4-Pin Threaded M12/Euro-Style Cordsets—Washdown, Stainless Steel cordsets listed in the *Accessories* section.



Note: These proximity switches shall be used with UL Listed Cable assemblies rated 30 V, 0.24 A minimum, in the field installation.

Adjustments

QM26 **Emitter**—Beam Enable: Connect black wire to +V dc to activate emitter LED
AFxxx models—Adjustment Screw: Sets background suppression distance
XLPC models—Push **Button**: User set up
XLPC models—Remote Input Wire: Remote PLC set up and push button lock out

Environmental Rating

IEC IP67 and IEC IP69K

Chemical Compatibility

ECOLAB® certified

Operating Conditions

Operating Temperature and Storage Temperature: -30 °C to +70 °C (-22 °F to +158 °F)



Note: UL certified in the temperature range -30 °C to +55 °C (-22 °F to +131 °F).

Humidity: Periodic exposure to 100% humidity and washdown cleaning

Vibration and Shock

IEC60947-5-2

Certifications



with class 2 power supply

QM26 Dimensions

All measurements are listed in millimeters [inches], unless noted otherwise.

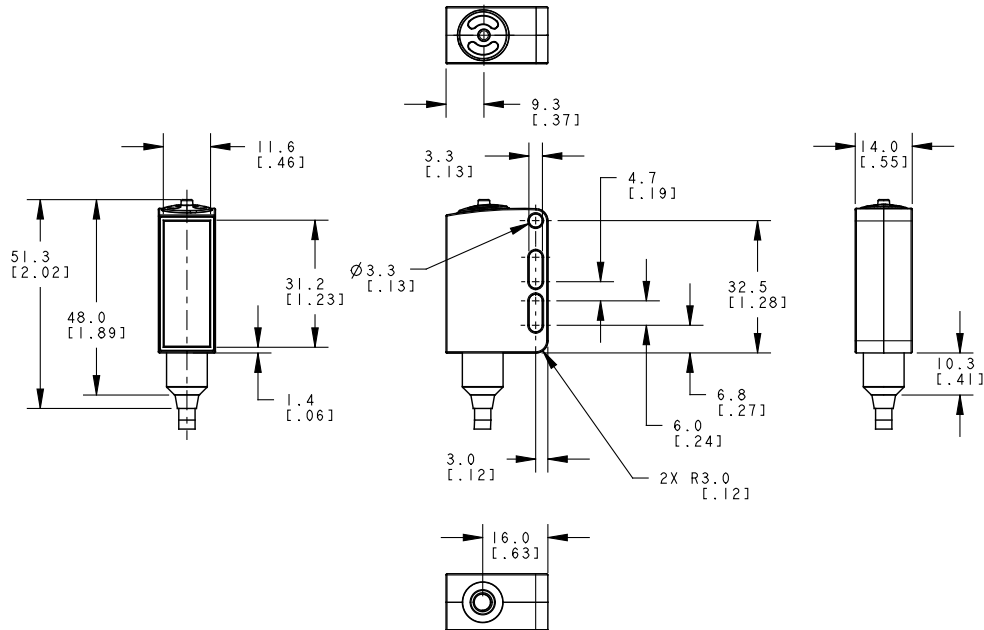

QMH26 Dimensions

All measurements are listed in millimeters [inches], unless noted otherwise.

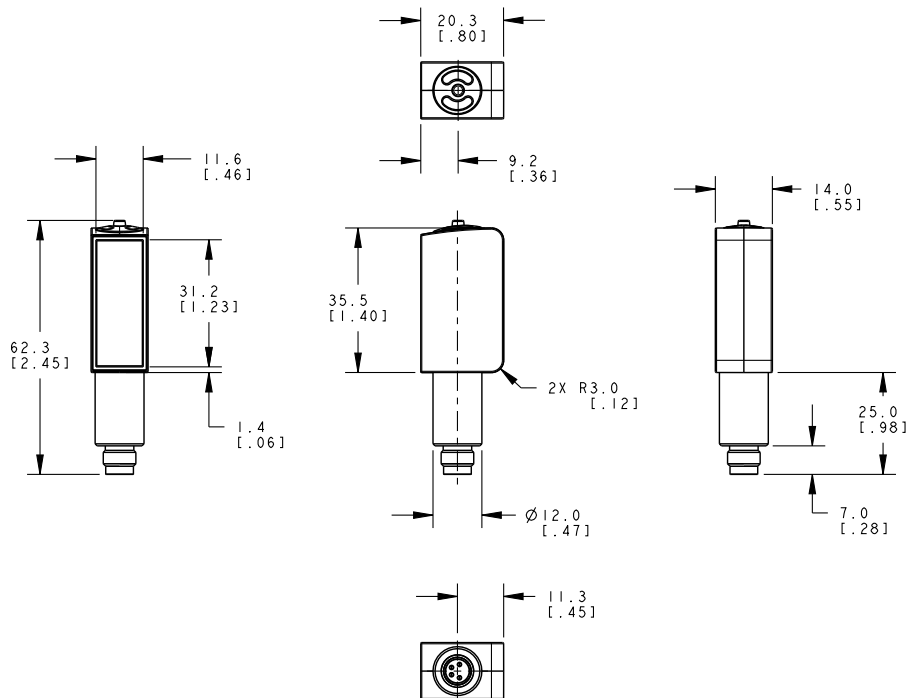

Performance Curves

Minimum Separation Distance

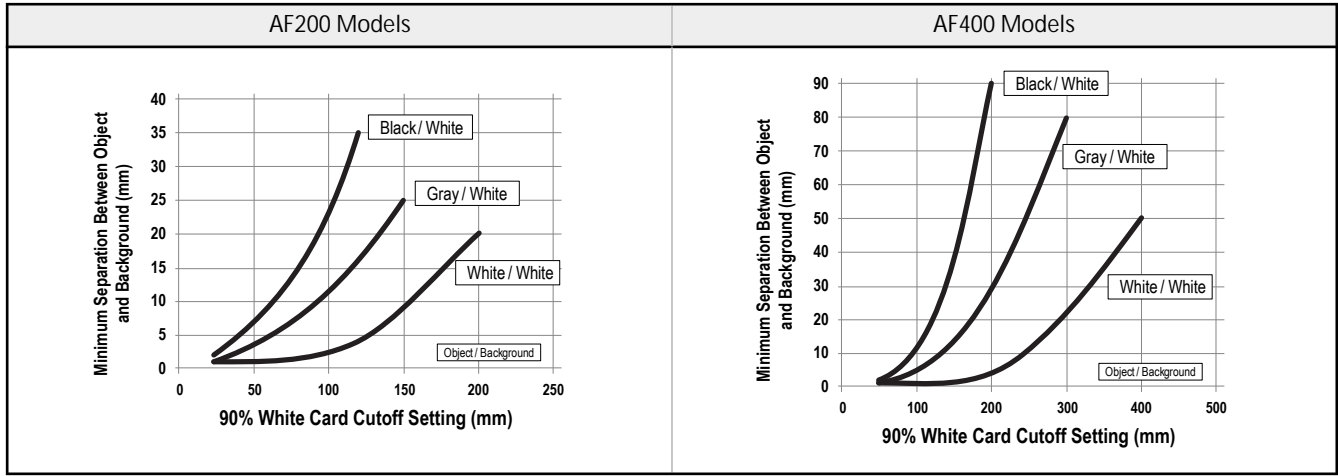

Figure 5. Minimum Separation Distance

Minimum Sensing Range

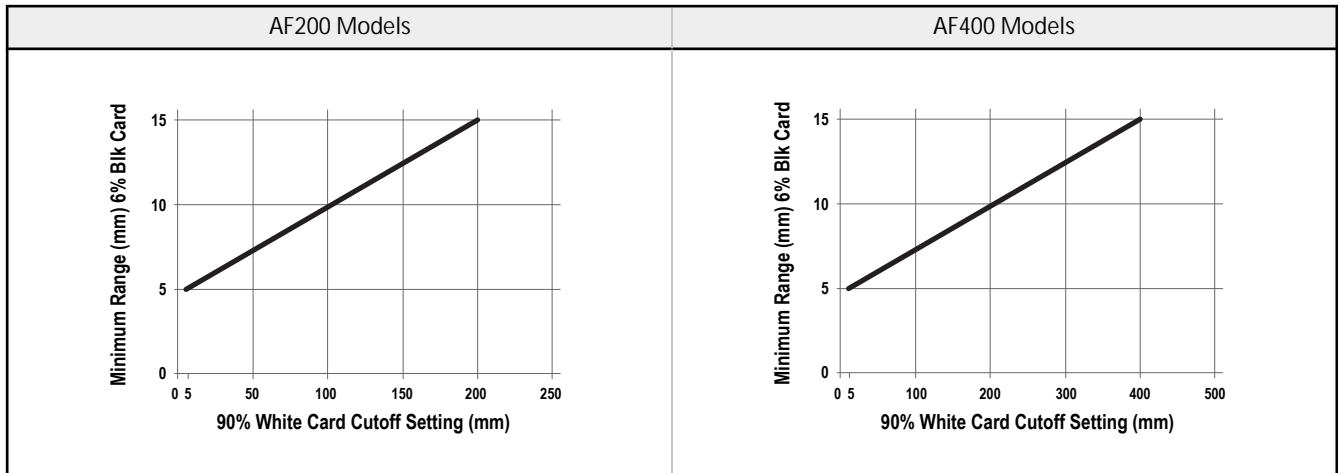

Figure 6. Minimum Sensing Range (Dead Zone)

Excess Gain

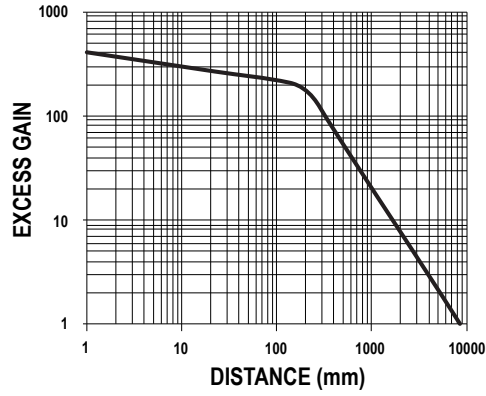

Figure 7. Opposed Mode Models

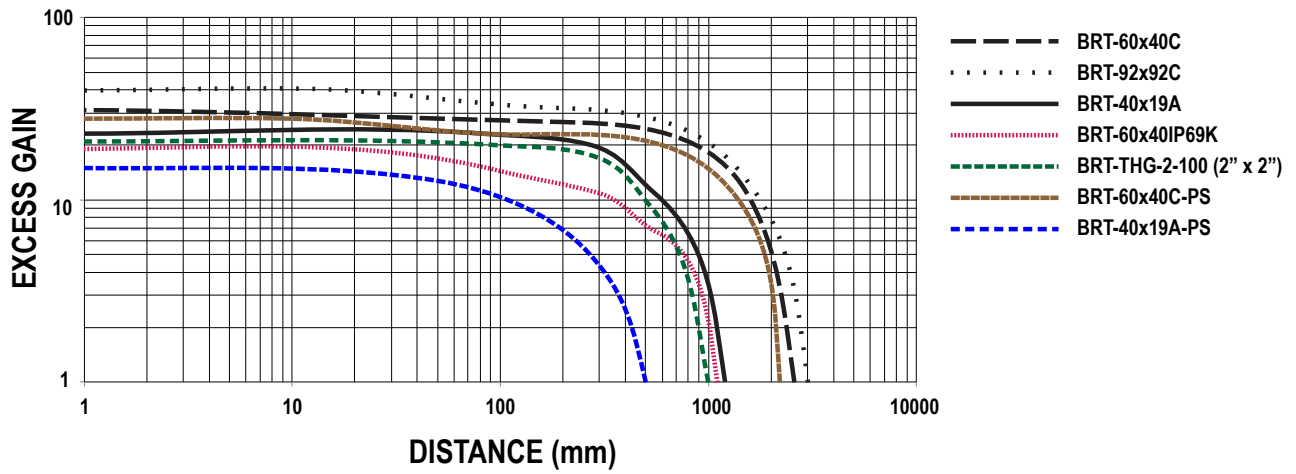

Figure 8. Expert™ Retroreflective Models (XLPC Models)

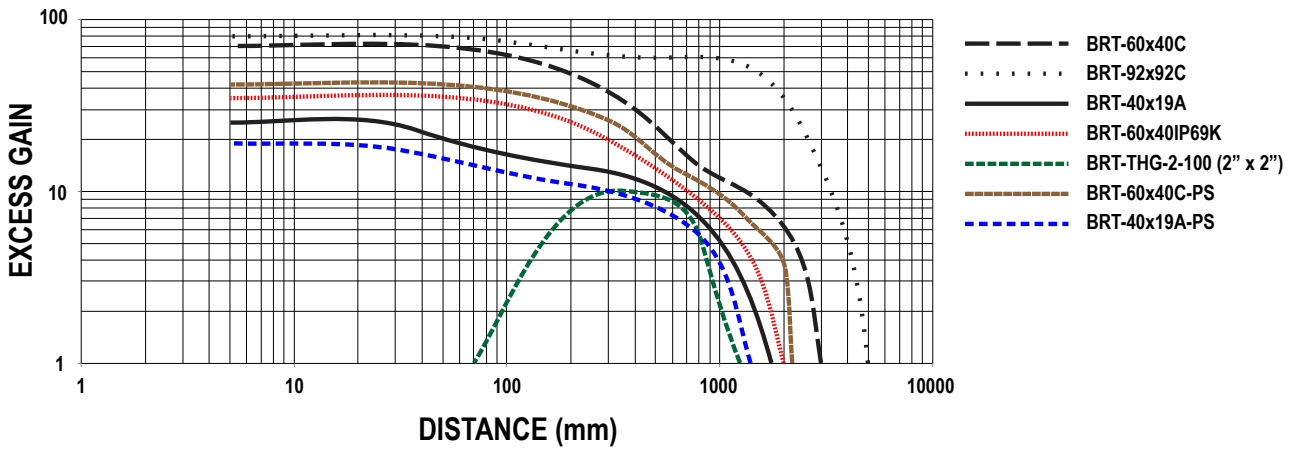

Figure 9. Fixed Gain Retroreflective Models (LP models)

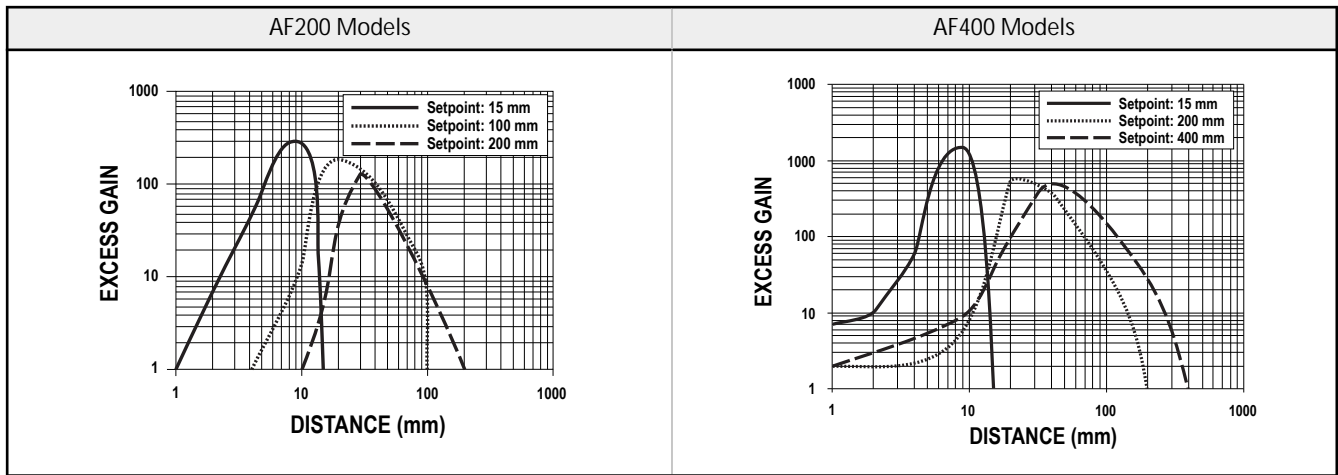
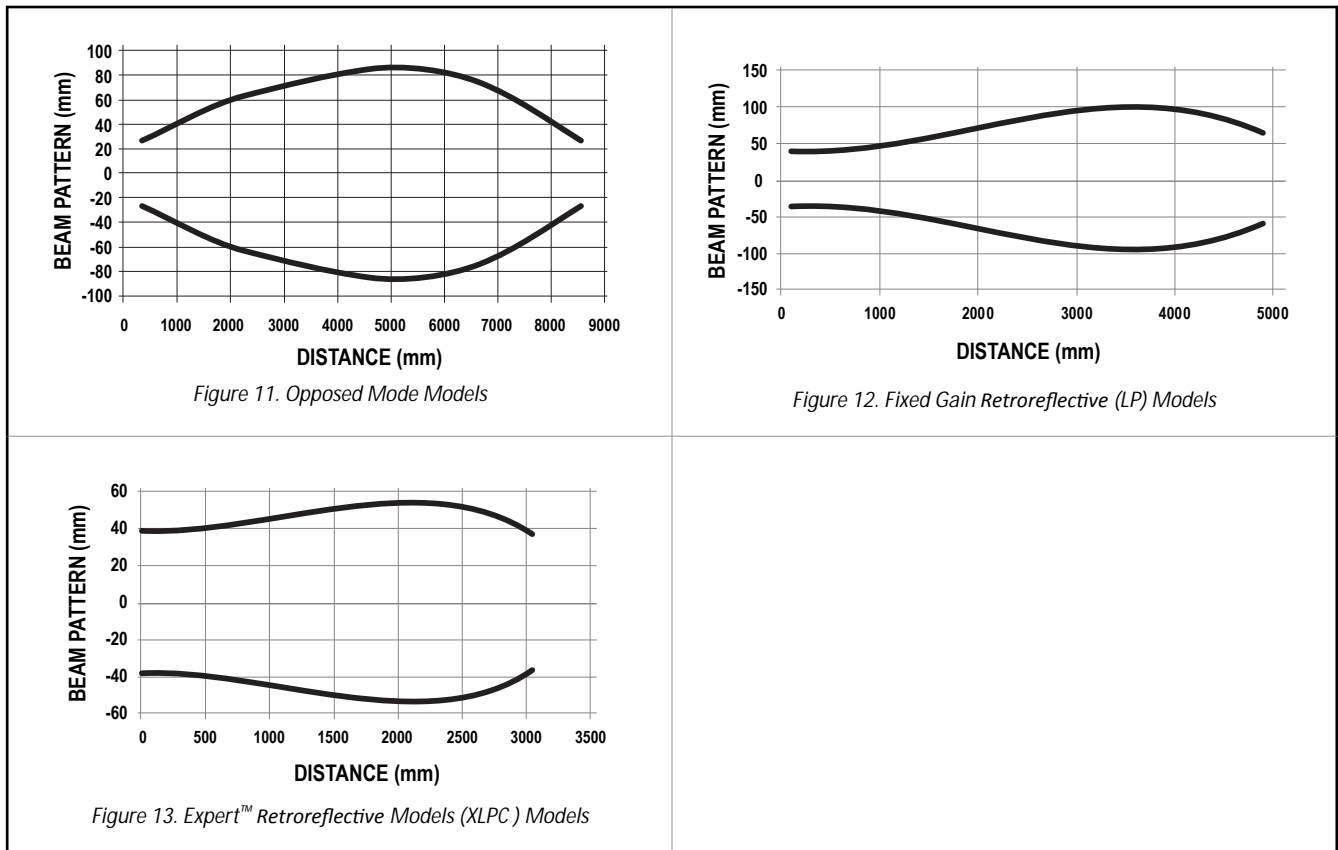

Figure 10. Adjustable Field Models (AFxxx Models)

Beam Patterns



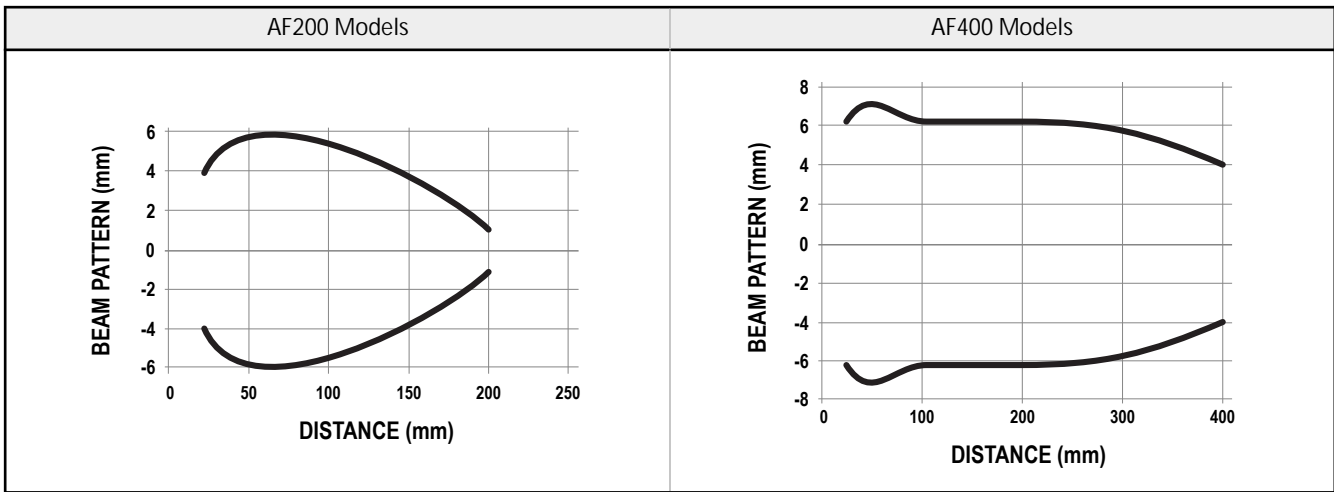
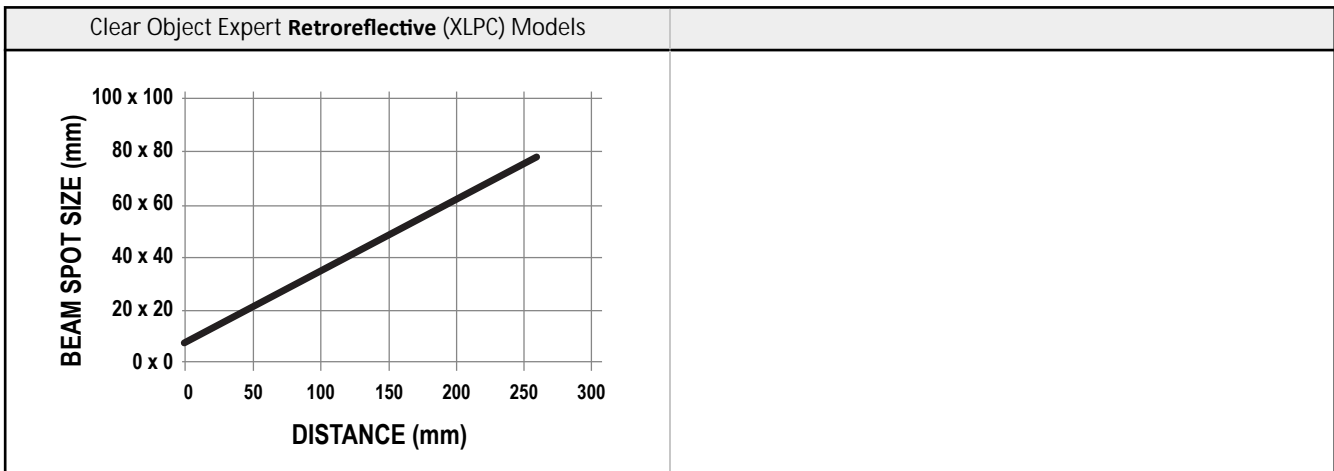

Figure 14. Adjustable Field Models (AFxxx Models)

Spot Size Versus Distance



Accessories

Cordsets for QM26 Models with Suffix Q5

All measurements are listed in millimeters, unless noted otherwise.

4-Pin Threaded M12/Euro-Style Cordsets (Washdown, Stainless Steel) (Recommended)

- Cable: PVC cable, stainless steel coupling nut, EPDM o-ring
- Conductors: 22 AWG, gold-plated contacts
- Voltage/Current **Rating:** 300 V dc, 4.0 A
- Temperature: -40 °C to +105 °C (-40 °F to +221 °F)
- Environmental **Rating:** IEC IP69K

4-Pin Threaded M12/Euro-Style Cordsets—Washdown, Stainless Steel				
Model	Length	Style	Dimensions	Pinout (Female)
MQDC-WDSS-0406	1.83 m (6 ft)	Straight		<p>1 = Brown 2 = White 3 = Blue 4 = Black</p>
MQDC-WDSS-0415	4.57 m (15 ft)			
MQDC-WDSS-0430	9.14 m (30 ft)			

4-Pin Threaded M12/Euro-Style Cordsets

Cable: PVC jacket, PUR (polyurethane) connector body, nickel-plated brass coupling nut
 Conductors: 22 AWG, gold-plated contacts
 Voltage/Current **Rating:** 250 V ac/dc, 4.0 A
 Temperature: -40 °C to +105 °C (-40 °F to +221 °F)
 Environmental **Rating:** IP67/IP69K

4-Pin Threaded M12/Euro-Style Cordsets				
Model	Length	Style	Dimensions	Pinout (Female)
MQDC-406	1.83 m (6 ft)	Straight		
MQDC-415	4.57 m (15 ft)			
MQDC-430	9.14 m (30 ft)			
MQDC-450	15.2 m (50 ft)			

Cordsets for QMH26 Models with suffix Q7

All measurements are listed in millimeters, unless noted otherwise.

4-Pin Threaded M8/Pico-Style Cordsets				
Model	Length	Style	Dimensions	Pinout (Female)
PKG4M-2	2 m (6.56 ft)	Straight		
PKG4M-5	5 m (16.4 ft)			
PKG4M-9	9 m (29.5 ft)			
PKW4M-2	2 m (6.56 ft)	Right Angle		
PKW4M-5	5 m (16.4 ft)			
PKW4M-9	9 m (29.5 ft)			

Brackets for QM26 Models

All measurements are listed in millimeters, unless noted otherwise.

<p>SMBLSTDQ26</p> <ul style="list-style-type: none"> Adjustable right-angle metal bracket 304 stainless steel 	<p>SMBLSTQ26</p> <ul style="list-style-type: none"> Right-angle bracket 304 stainless steel
---	---

Brackets for QMH26 Models

All measurements are listed in millimeters, unless noted otherwise.

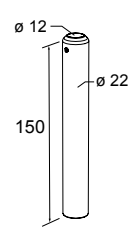
<p>SMBQM26-SS-150</p> <ul style="list-style-type: none"> • Smooth surfaces for easy cleaning • Setscrew adjustment of sensor • 316L stainless steel 	
--	---

Retroreflectors

All measurements are listed in millimeters, unless noted otherwise.

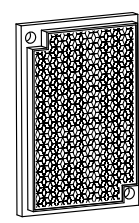
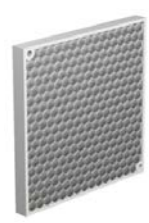
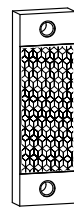
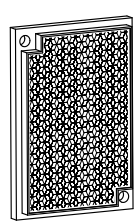
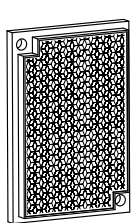
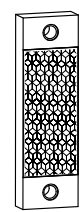
<p>BRT-60X40C</p> <ul style="list-style-type: none"> • Rectangular, acrylic target • Reflectivity Factor: 1.4 • Temperature: -20 °C to +60 °C (-4 °F to +140 °F) • Optional brackets are available • Approximate size: 40 mm × 60 mm 		<p>BRT-92X92C</p> <ul style="list-style-type: none"> • Square, acrylic target • Reflectivity Factor: 3.0 • Temperature: -20 °C to +60 °C (-4 °F to +140 °F) • Optional brackets are available • Approximate size: 92 mm × 92 mm 	
<p>BRT-40X19A</p> <ul style="list-style-type: none"> • Rectangular, acrylic target • Reflectivity Factor: 1.3 • Temperature: -20 °C to +60 °C (-4 °F to +140 °F) • Approximate size: 19 mm × 60 mm overall; 19 mm × 40 mm reflector 		<p>BRT-60X40IP69K</p> <ul style="list-style-type: none"> • Rectangular, acrylic target (color is amber) • Reflectivity Factor: 0.7 • Temperature: -20 °C to +140 °C (-4 °F to +284 °F) • Chemically resistant • IP69K washdown rated • Optional brackets are available • Approximate size: 40 mm × 60 mm 	
<p>BRT-60X40C-PS</p> <ul style="list-style-type: none"> • Rectangular, polystyrene target • Reflectivity Factor: 1.1 • Temperature: -20 °C to +60 °C (-4 °F to +140 °F) • Optional brackets are available • Chemically compatible with hydrogen peroxide • Yellow back • Approximate size: 40 mm × 60 mm 		<p>BRT-40X19A-PS</p> <ul style="list-style-type: none"> • Rectangular, polystyrene target • Reflectivity Factor: 1.0 • Temperature: -20 °C to +60 °C (-4 °F to +140 °F) • Chemically compatible with hydrogen peroxide • Yellow back • Approximate size: 19 mm × 60 mm overall; 19 mm × 40 mm reflector 	

Model	Reflectivity Factor	Maximum Temperature	Size
BRT-THG-2-100	0.7	+60 °C (+140 °F)	50 mm (2 in) wide, 2.5 m (100 in) long