



Preliminary

# QPA2962

## 2 – 20 GHz 10 Watt GaN Amplifier

### Product Overview

Qorvo's QPA2962 is a wideband power amplifier fabricated on Qorvo's QGaN15 GaN on SiC process. The QPA2962 operates from 2 to 20 GHz, providing 10 W of saturated power with 13 dB large signal gain and 22 % power-added efficiency at 22 V drain bias. RF ports are matched to 50  $\Omega$ , including integrated DC blocking capacitors and a RF choke.

Packaged in a 5 x 5 mm air cavity laminate package, QPA2962 provides designers with a convenient SMT compatible device that delivers a valuable combination of wideband power, gain and efficiency while reducing size and cost. QPA2962 is ideally suited for wideband communications systems, electronic warfare, test instrumentation and radar applications across both military and commercial markets.

QPA2962 is 100% DC and RF tested on-wafer to ensure compliance to electrical specifications.

Lead free and RoHS compliant.

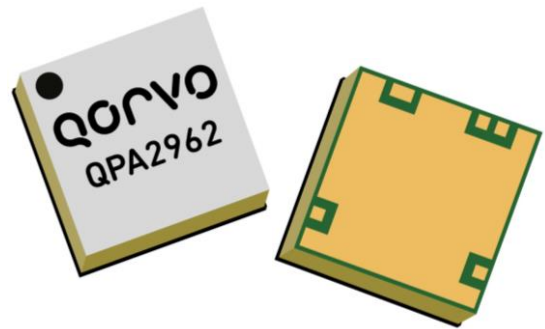

### Key Features

- Frequency Range: 2 – 20 GHz
- $P_{SAT}$  ( $P_{IN}=27$  dBm): 40 dBm
- PAE ( $P_{IN}=27$  dBm): 22 %
- Power Gain ( $P_{IN}=27$  dBm): 13 dBm
- Small Signal Gain: 19 dB
- Bias:  $V_D = 22$  V,  $I_{DQ} = 1680$  mA
- Package Dimensions: 5.0 x 5.0 x 1.455 mm

*Performance is typical across frequency. Please reference electrical specification table and data plots for more details.*

### Functional Block Diagram

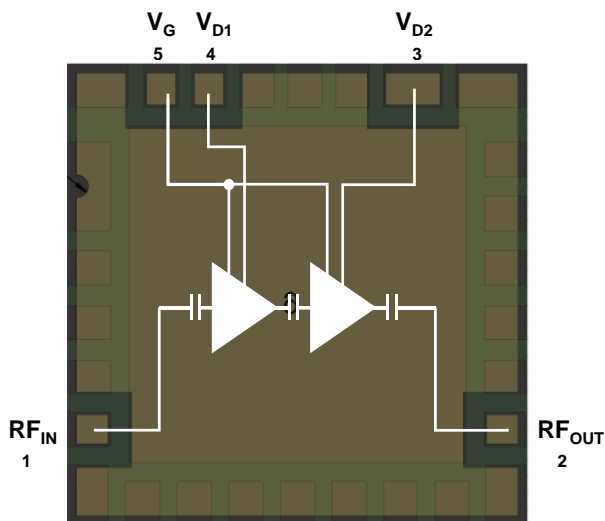

### Applications

- Communication Systems
- Electronic Warfare
- Radar
- Test Equipment

### Ordering Information

Part No.	Description
QPA2962	2 - 20 GHz 10 Watt GaN Amplifier
QPA2962TR7	250 pieces on a 7" reel (standard)
QPA2962EVB	Evaluation Board for QPA2962

### Absolute Maximum Ratings

Parameter	Value / Range
Drain Voltage ( $V_D$ )	29.5 V
Gate Voltage Range ( $V_G$ )	-4 to 0 V
Drain Current ( $I_D$ )	2848 mA
Gate Current ( $I_G$ )	10 mA
Power Dissipation ( $P_{DISS}$ ), $T_{BASE} = 85^\circ\text{C}$	40 W
Input Power ( $P_{IN}$ ), 50 $\Omega$ , $V_D = 22$ V, $I_{DQ} = 1680$ mA, $T_{BASE} = 85^\circ\text{C}$	33 dBm
Input Power ( $P_{IN}$ ), 3:1 VSWR, $V_D = 22$ V, $I_{DQ} = 1680$ mA, $T_{BASE} = 85^\circ\text{C}$	32 dBm
Mounting Temperature (30 seconds max)	260 $^\circ\text{C}$
Storage Temperature	-55 to 150 $^\circ\text{C}$

Operation of this device outside the parameter ranges given above may cause permanent damage. These are stress ratings only, and functional operation of the device at these conditions is not implied.

### Recommended Operating Conditions

Parameter	Min	Typ	Max	Units
Drain Voltage ( $V_D$ )		22		V
Drain Current, Quiescent ( $I_{DQ}$ )		1680		mA
Drain Current, RF ( $I_{D\_Drive}$ )	See charts page 6, 7, 10, 13, 16			mA
Gate Voltage Typ. Range ( $V_G$ )	-1.2 to -2.5			V
Gate Current, RF ( $I_{G\_Drive}$ )	See charts page 6 - 7			mA
Operating Temp. Range, $T_{BASE}$	-40	+25	+85	$^\circ\text{C}$

Electrical specifications are measured at specified test conditions. Specifications are not guaranteed over all recommended operating conditions.

### Electrical Specifications

Parameter	Conditions <sup>(1)</sup> <sup>(2)</sup>	Min	Typ	Max	Units
Operational Frequency Range		2		20	GHz
Output Power at Saturation, $P_{SAT}$	$P_{IN} = +27$ dBm, Frequency = 2 - 18 GHz		40		dBm
	$P_{IN} = +27$ dBm, Frequency = 19 - 20 GHz		39		
Power Added Efficiency, PAE	$P_{IN} = +27$ dBm, Frequency = 2 - 18 GHz		22		%
	$P_{IN} = +27$ dBm, Frequency = 19 - 20 GHz		15		
Small Signal Gain, $S_{21}$			19		dB
Input Return Loss, IRL			10		dB
Output Return Loss, ORL			7		dB
$P_{SAT}$ Temperature Coefficient	$T_{DIFF} = -40^\circ\text{C}$ to $+85^\circ\text{C}$ ; $P_{IN} = +27$ dBm		-0.009		dBm/ $^\circ\text{C}$
$S_{21}$ Temperature Coefficient	$T_{DIFF} = -40^\circ\text{C}$ to $+85^\circ\text{C}$		-0.04		dB/ $^\circ\text{C}$

Notes:

1. Test conditions unless otherwise noted: CW,  $V_D = 22$  V,  $I_{DQ} = 1680$  mA, adjusting  $V_G$ ,  $T_{BASE} = +25^\circ\text{C}$ ,  $Z_0 = 50 \Omega$
2.  $T_{BASE}$  is back side of package

Performance Plots – Small Signal

Test conditions unless otherwise noted: CW,  $V_D = 22\text{ V}$ ,  $I_{DQ} = 1680\text{ mA}$ ,  $T_{BASE} = +25\text{ }^\circ\text{C}$

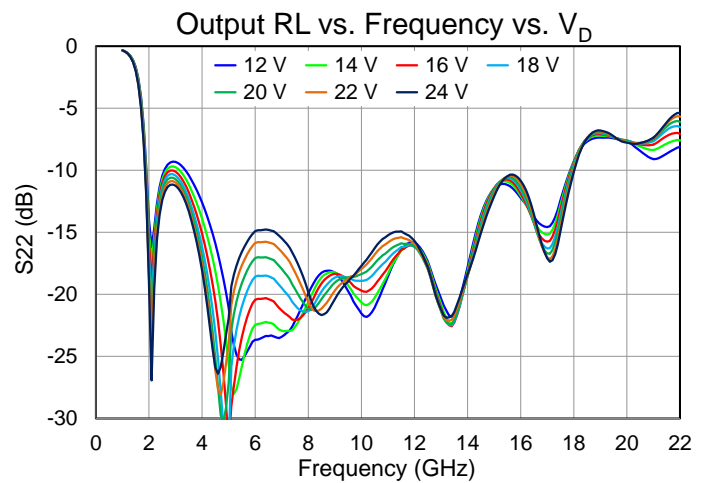
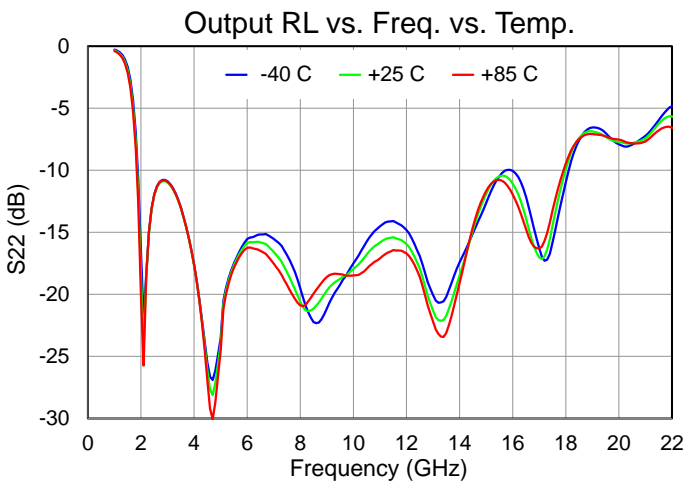
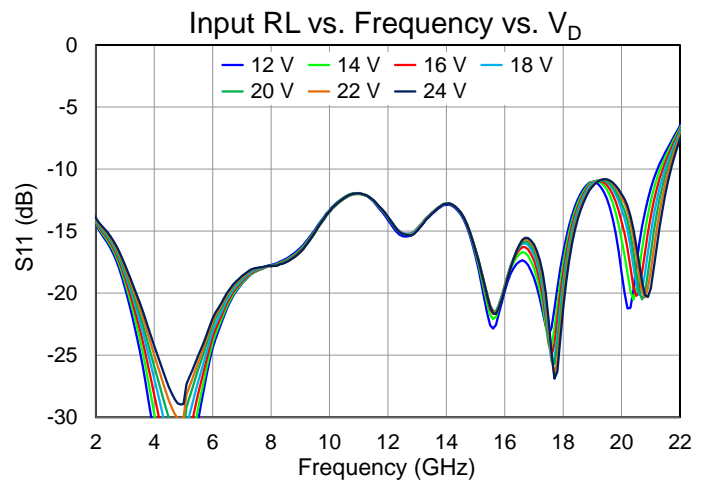
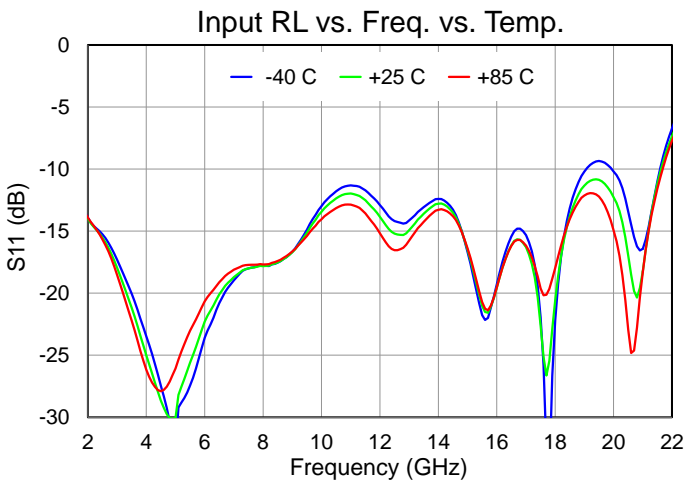
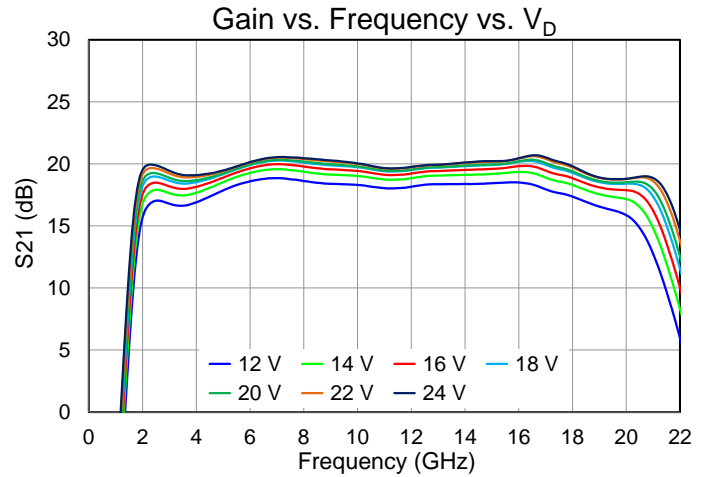
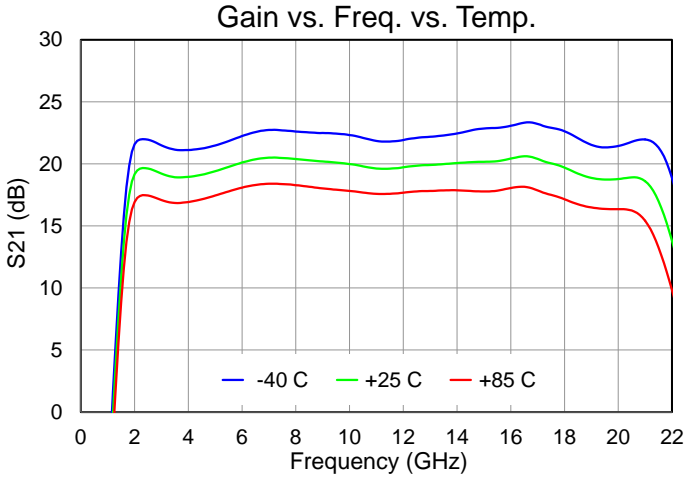

**Performance Plots – Small Signal**

Test conditions unless otherwise noted: CW,  $V_D = 22\text{ V}$ ,  $I_{DQ} = 1680\text{ mA}$ ,  $T_{BASE} = +25\text{ }^\circ\text{C}$

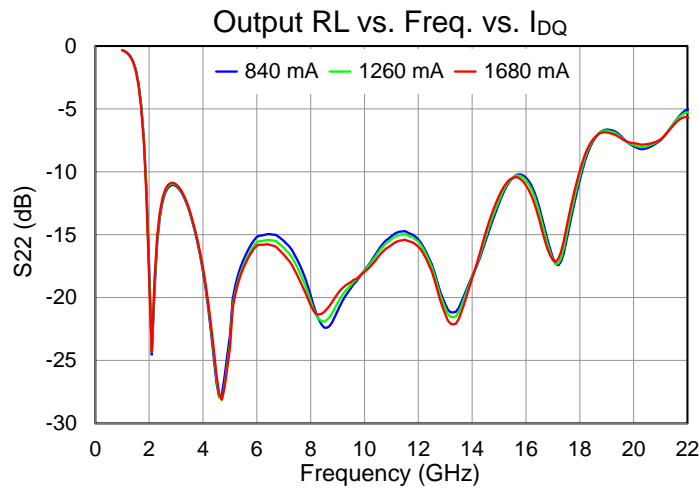
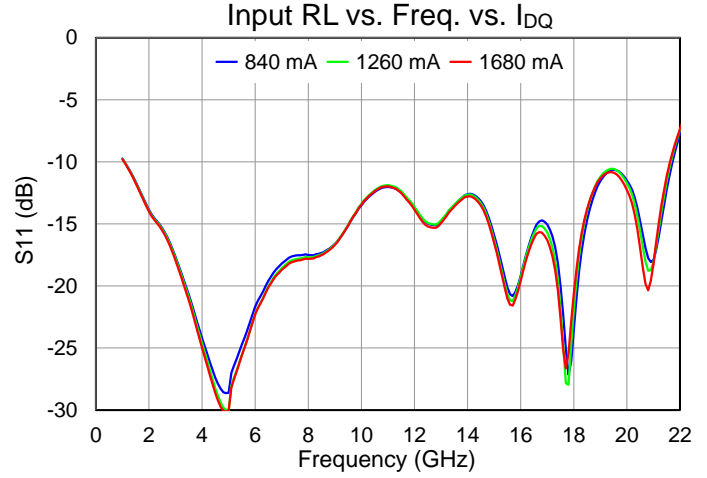
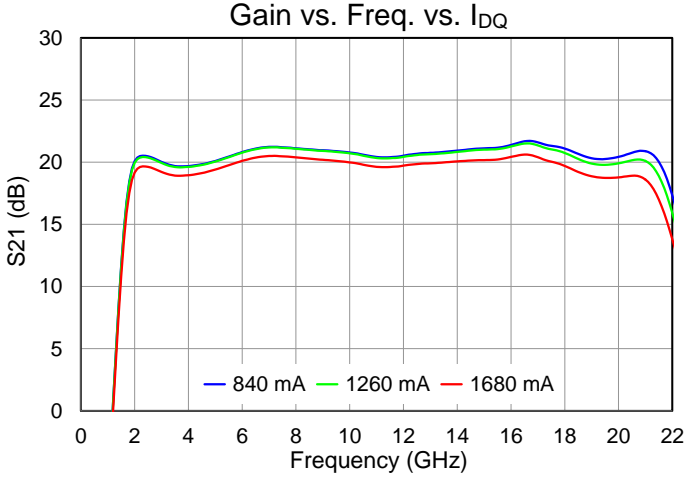

## Performance Plots – Large Signal

Test conditions unless otherwise noted: CW,  $V_D = 22\text{ V}$ ,  $I_{DQ} = 1680\text{ mA}$ ,  $P_{IN} = 27\text{ dBm}$ ,  $T_{BASE} = +25\text{ }^\circ\text{C}$

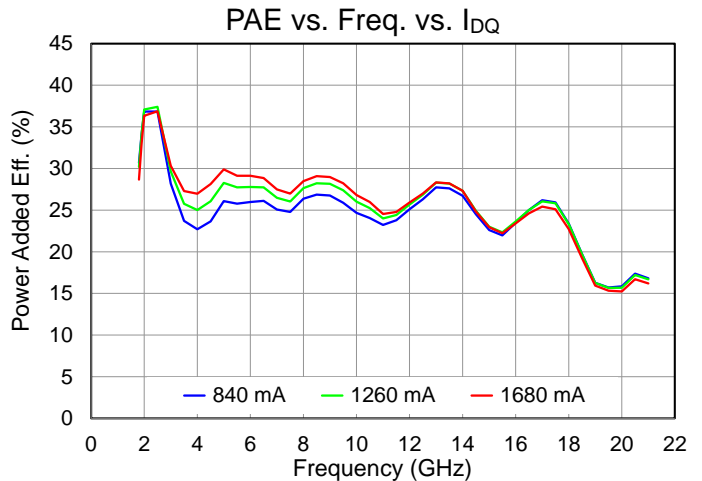
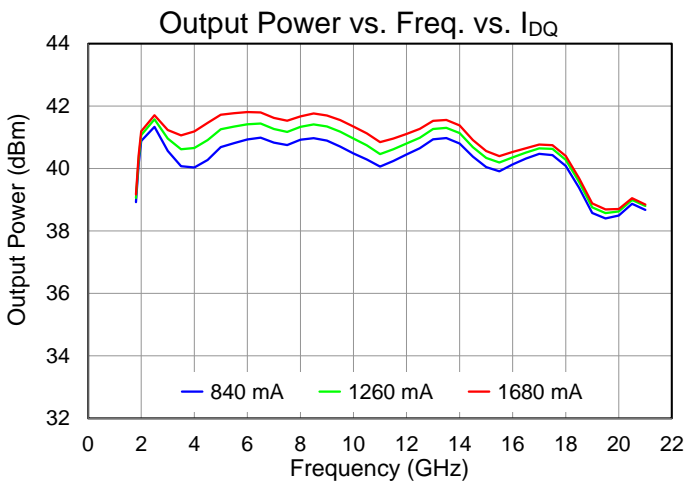
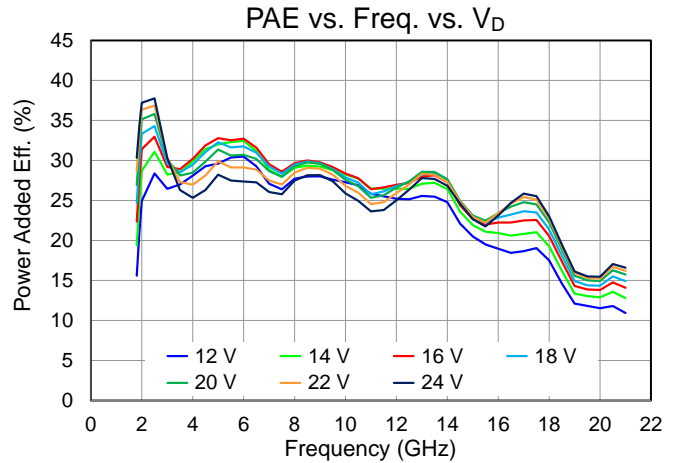
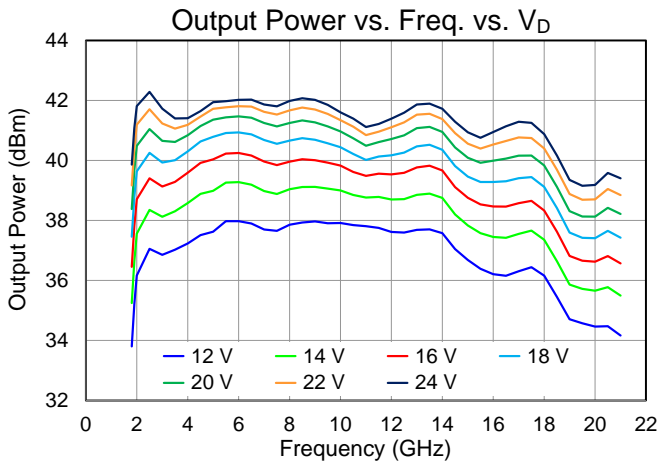
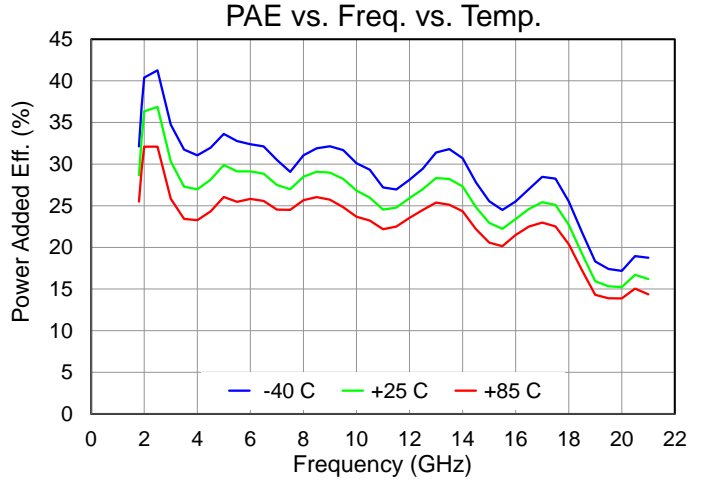
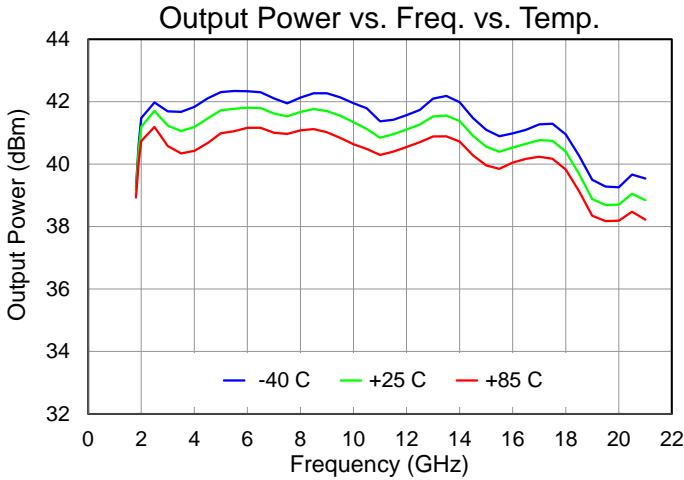

Performance Plots – Large Signal

Test conditions unless otherwise noted: CW,  $V_D = 22\text{ V}$ ,  $I_{DQ} = 1680\text{ mA}$ ,  $P_{IN} = 27\text{ dBm}$ ,  $T_{BASE} = +25\text{ }^\circ\text{C}$

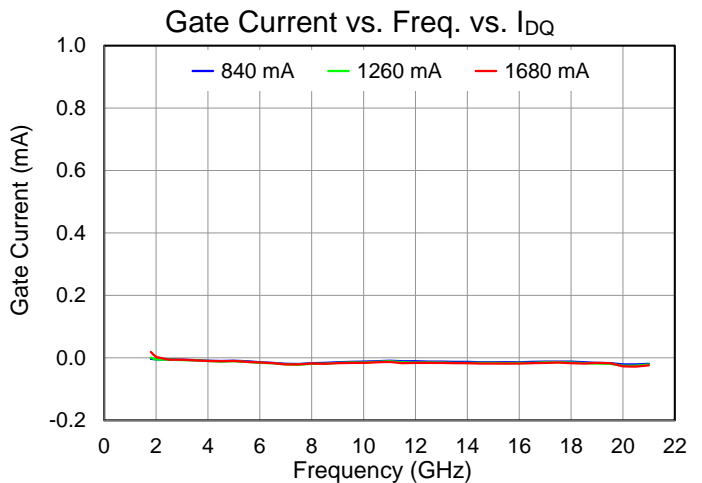
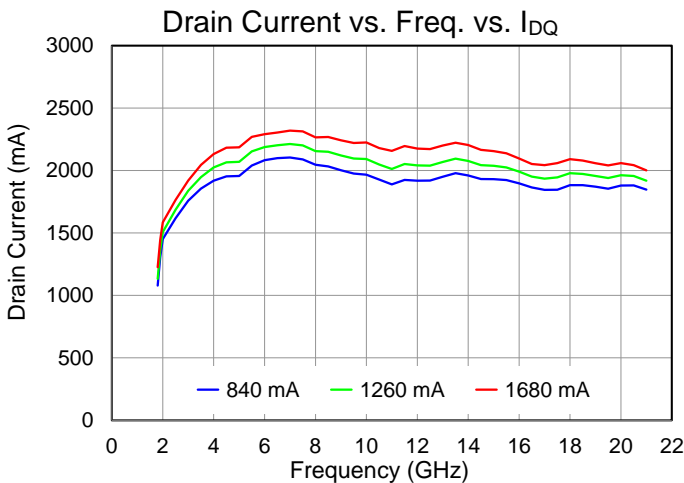
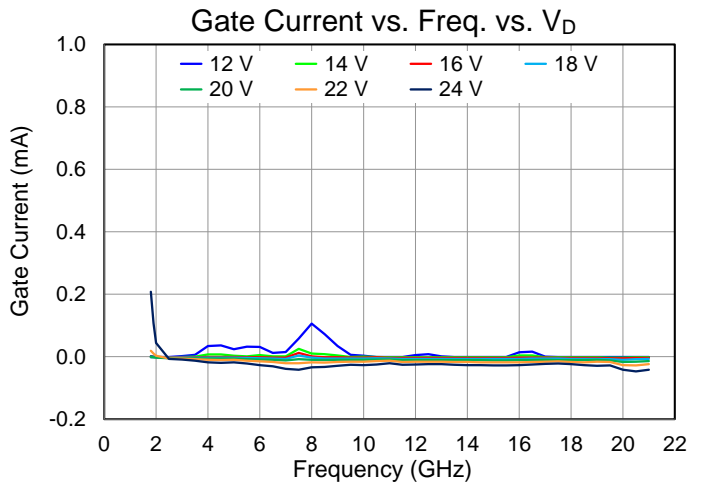
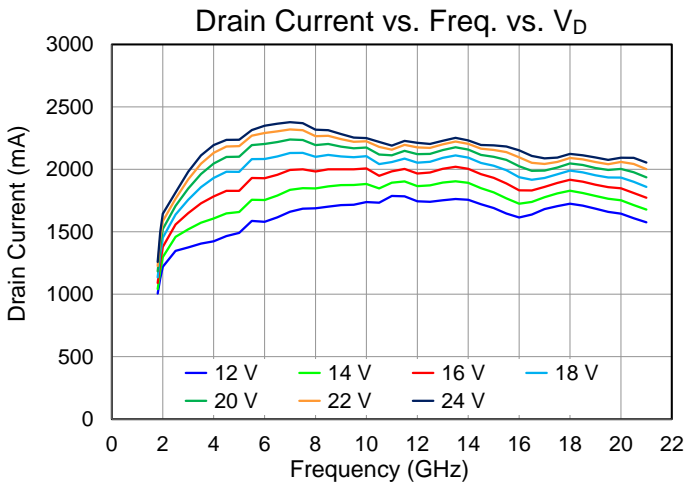
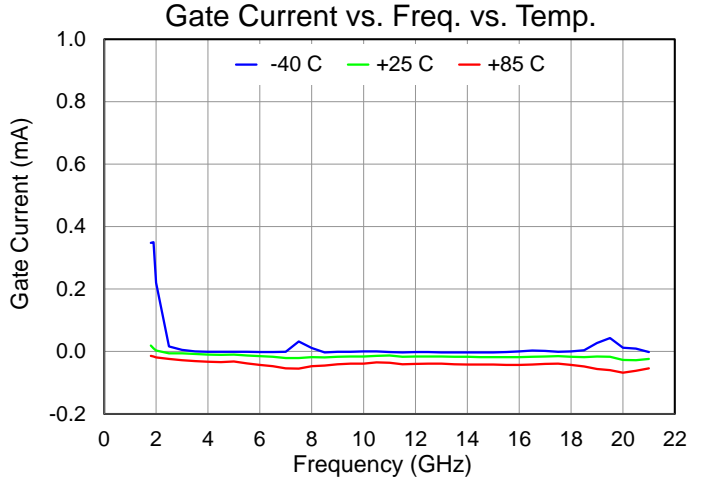
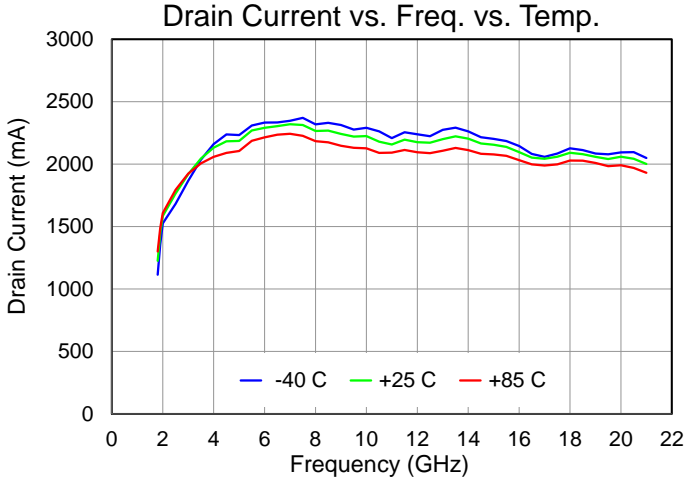

Performance Plots – Large Signal

Test conditions unless otherwise noted: CW,  $V_D = 22\text{ V}$ ,  $I_{DQ} = 1680\text{ mA}$ ,  $P_{IN} = 27\text{ dBm}$ ,  $T_{BASE} = +25\text{ }^\circ\text{C}$

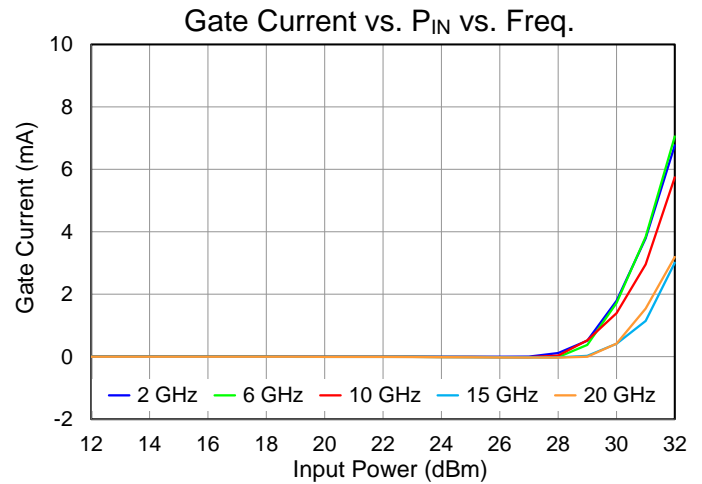
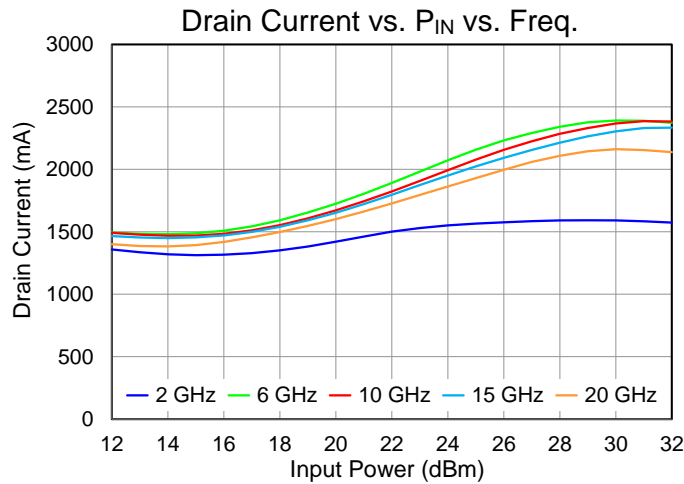
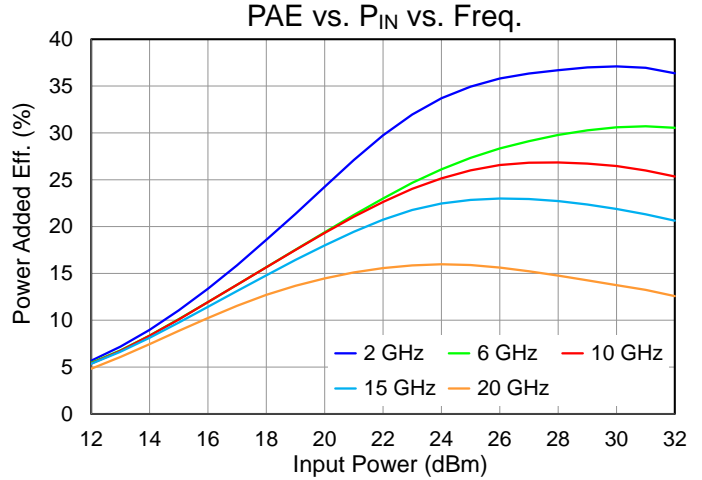
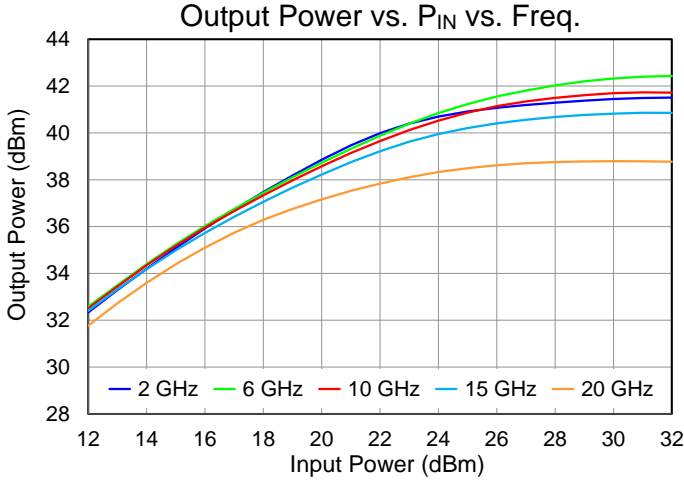

Performance Plots – Large Signal

Test conditions unless otherwise noted: CW,  $V_D = 22\text{ V}$ ,  $I_{DQ} = 1680\text{ mA}$ ,  $P_{IN} = 27\text{ dBm}$ ,  $T_{BASE} = +25\text{ }^\circ\text{C}$

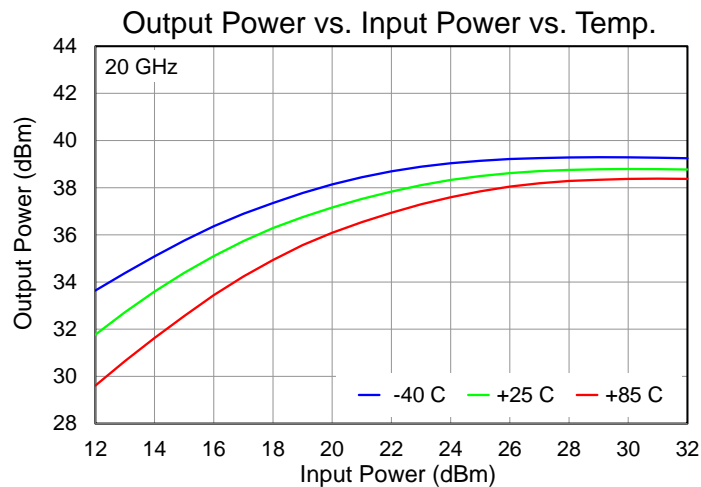
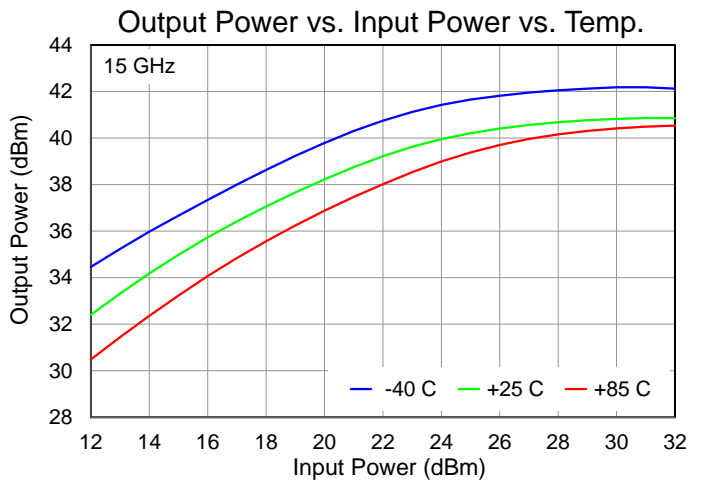
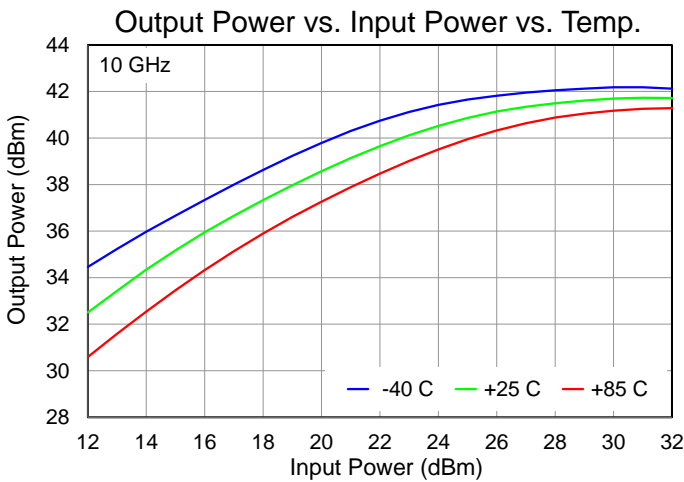
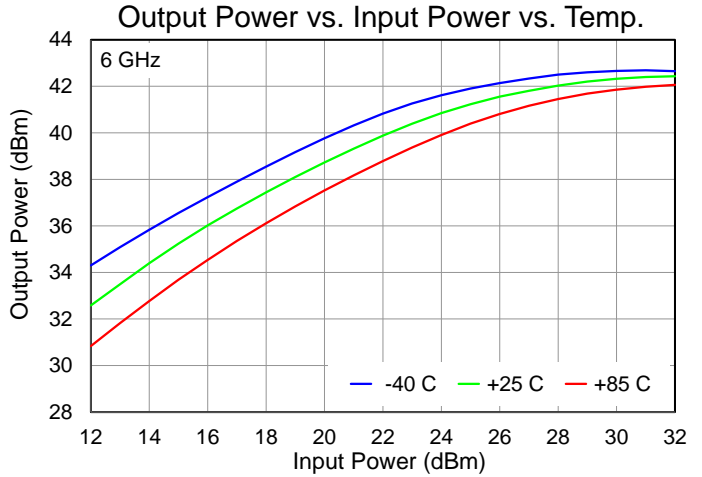
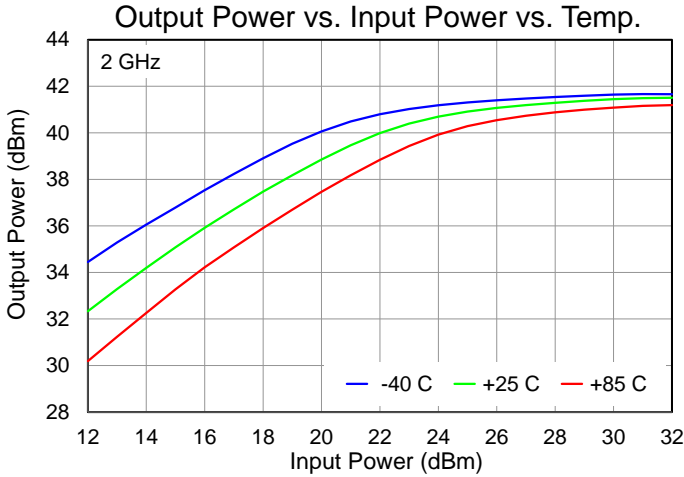



Performance Plots – Large Signal

Test conditions unless otherwise noted: CW,  $V_D = 22\text{ V}$ ,  $I_{DQ} = 1680\text{ mA}$ ,  $P_{IN} = 27\text{ dBm}$ ,  $T_{BASE} = +25\text{ }^\circ\text{C}$

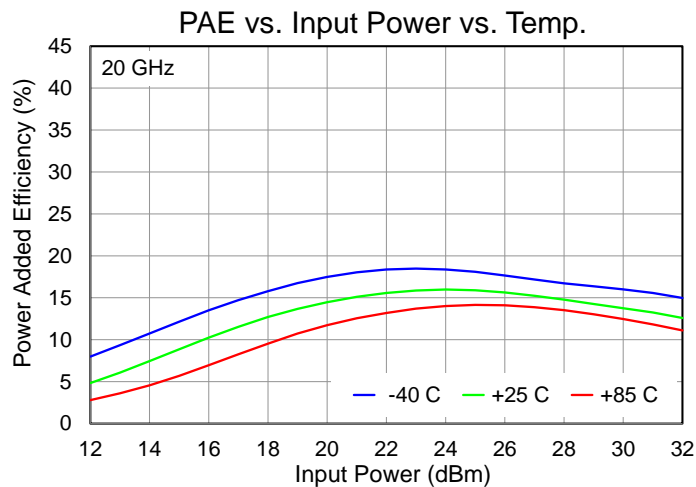
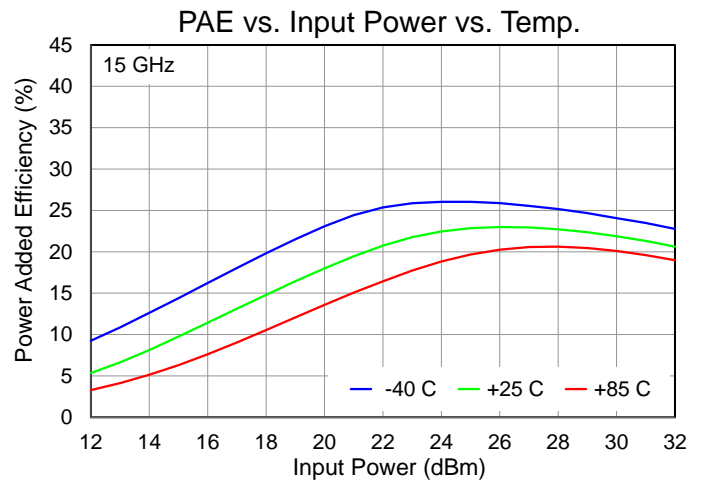
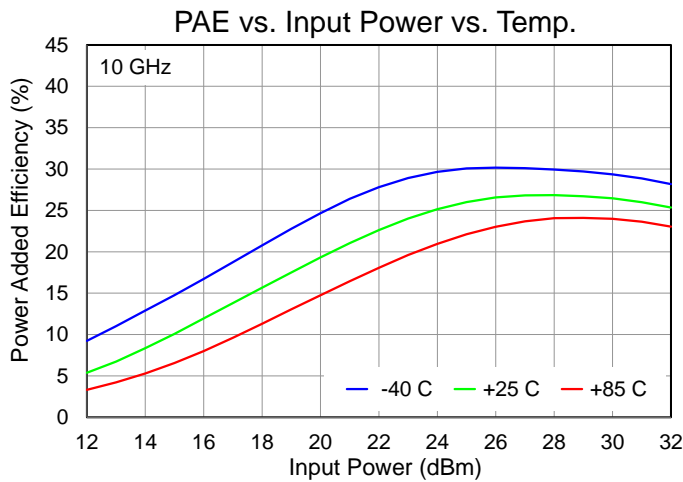
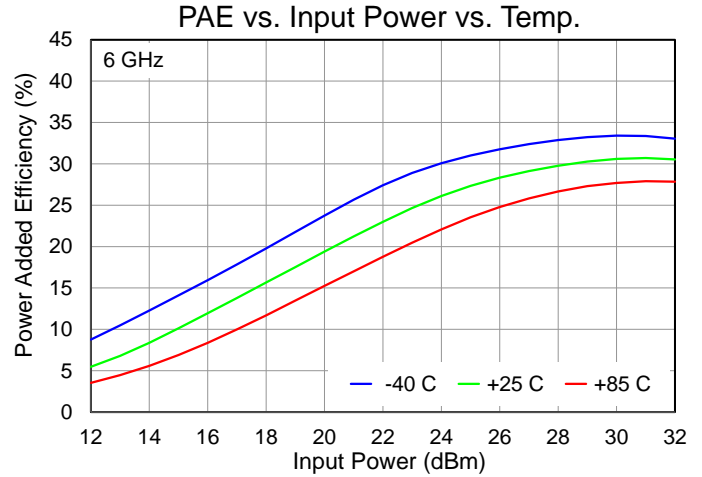
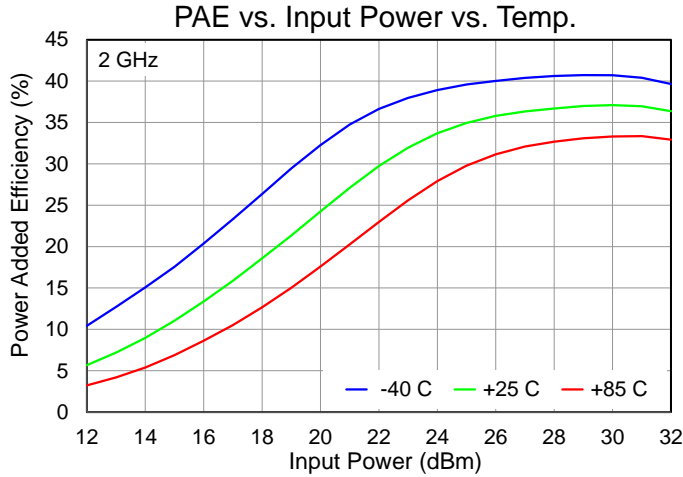

## Performance Plots – Large Signal

Test conditions unless otherwise noted: CW,  $V_D = 22\text{ V}$ ,  $I_{DQ} = 1680\text{ mA}$ ,  $P_{IN} = 27\text{ dBm}$ ,  $T_{BASE} = +25\text{ }^\circ\text{C}$

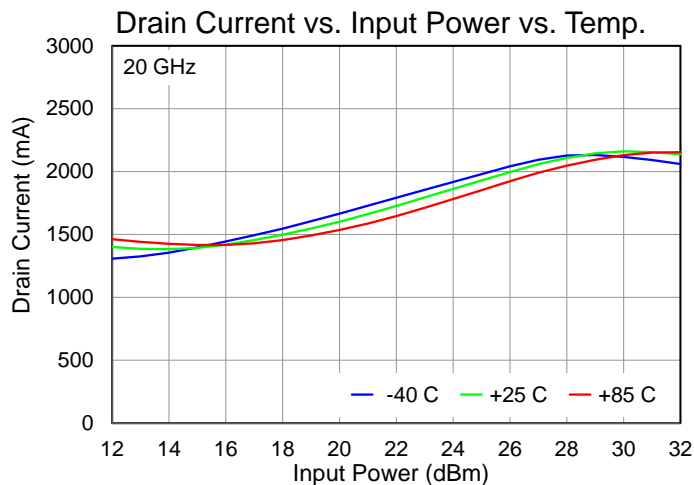
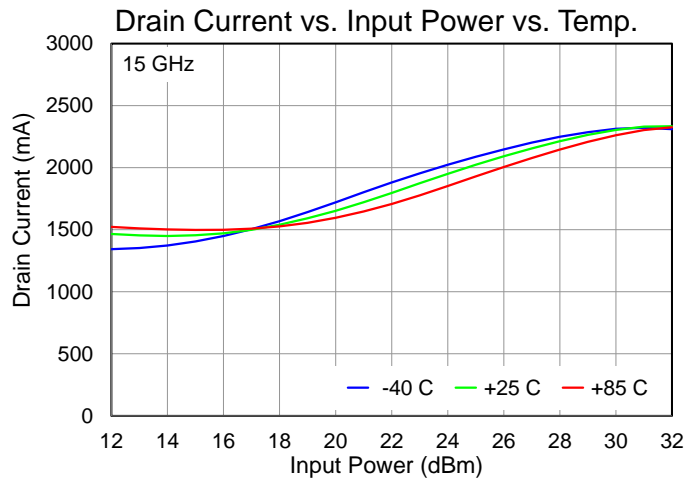
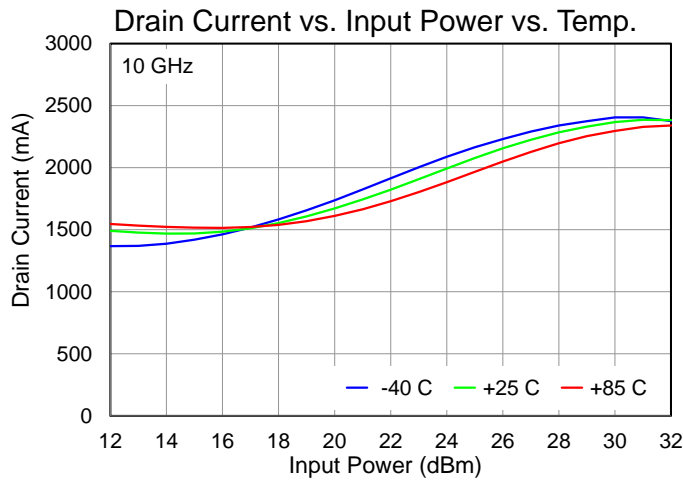
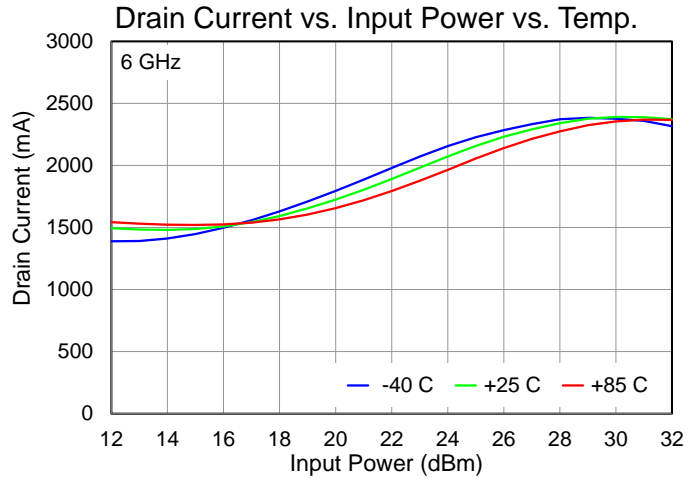
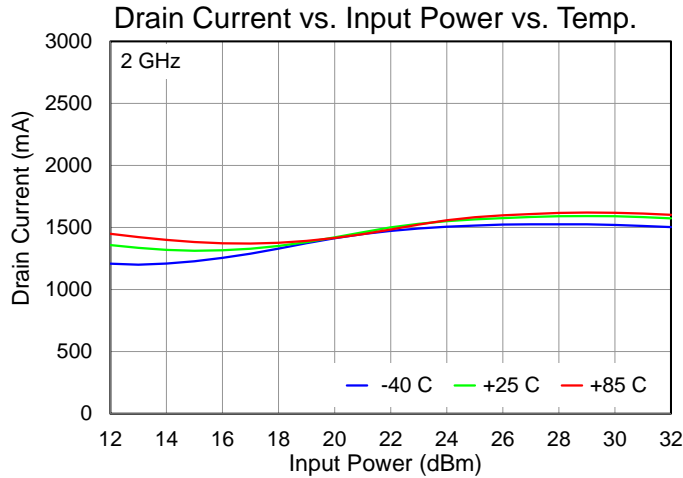

Performance Plots – Large Signal

Test conditions unless otherwise noted: CW,  $V_D = 22\text{ V}$ ,  $I_{DQ} = 1680\text{ mA}$ ,  $P_{IN} = 27\text{ dBm}$ ,  $T_{BASE} = +25\text{ }^\circ\text{C}$

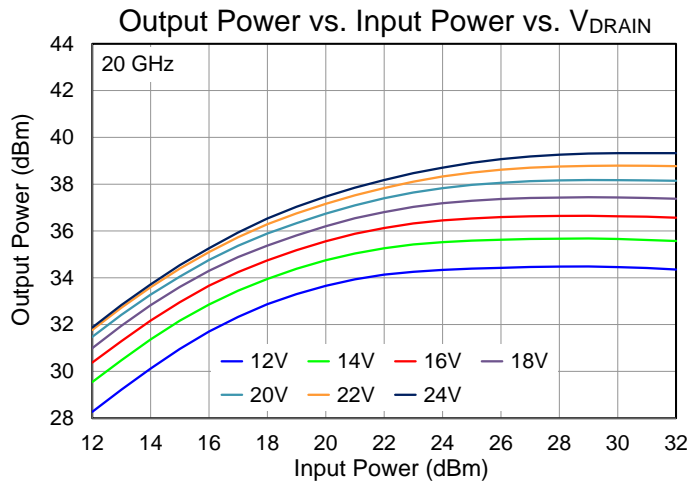
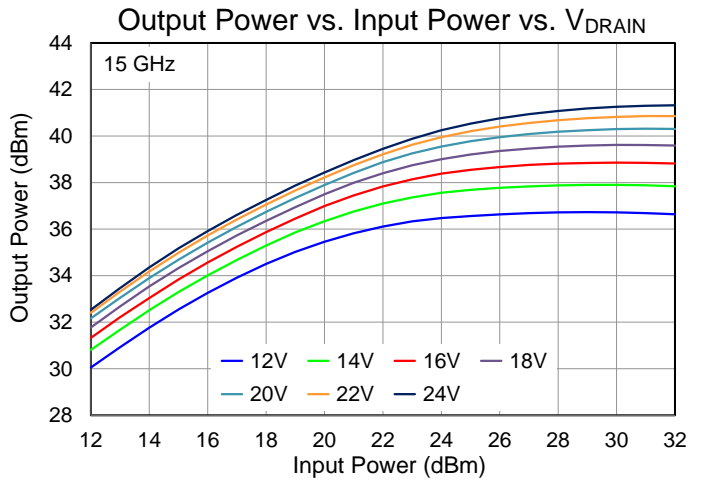
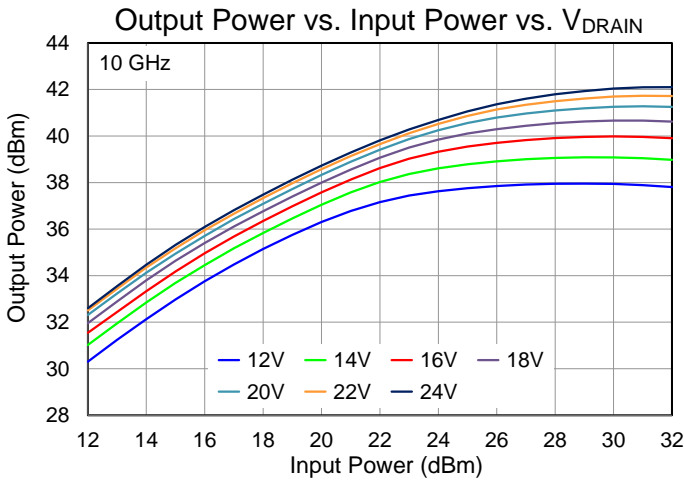
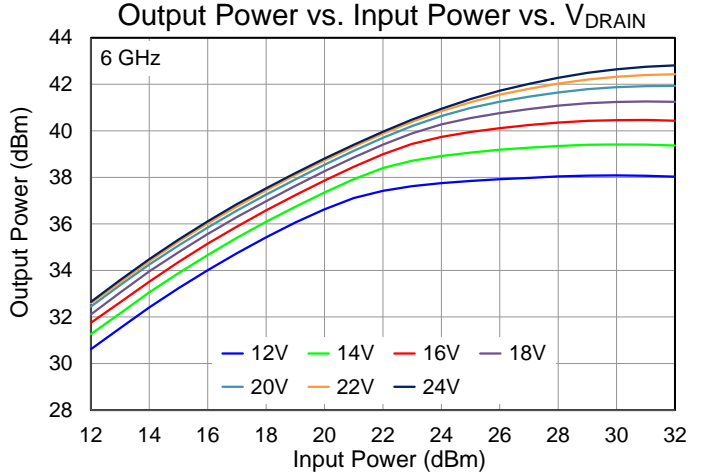
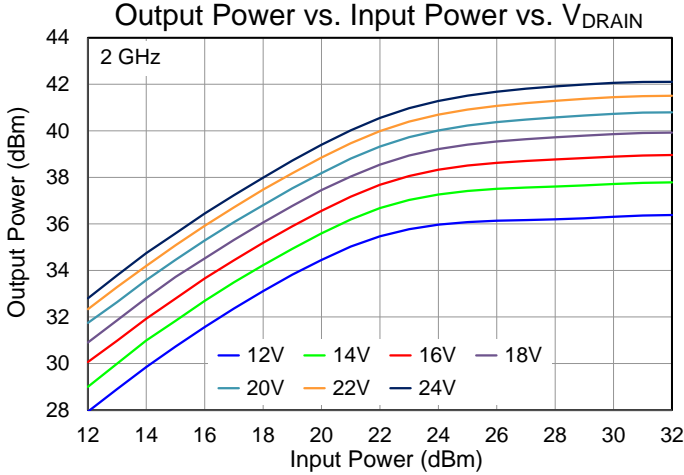

Performance Plots – Large Signal

Test conditions unless otherwise noted: CW,  $V_D = 22\text{ V}$ ,  $I_{DQ} = 1680\text{ mA}$ ,  $P_{IN} = 27\text{ dBm}$ ,  $T_{BASE} = +25\text{ }^\circ\text{C}$

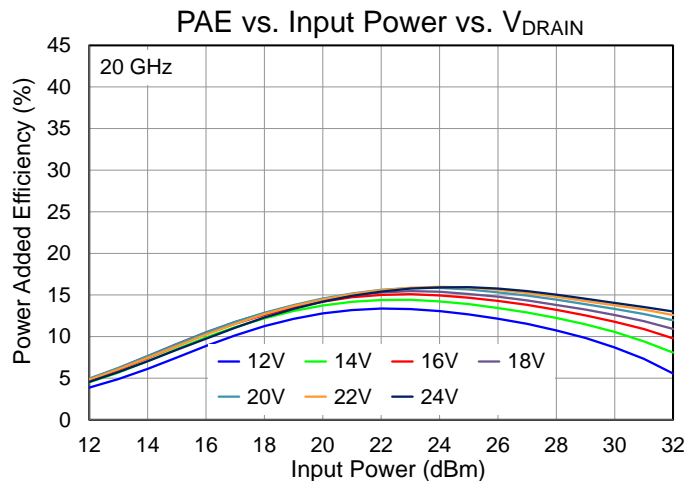
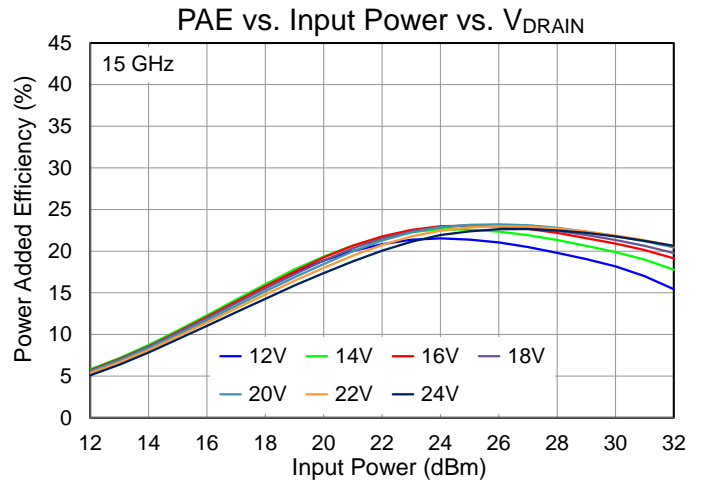
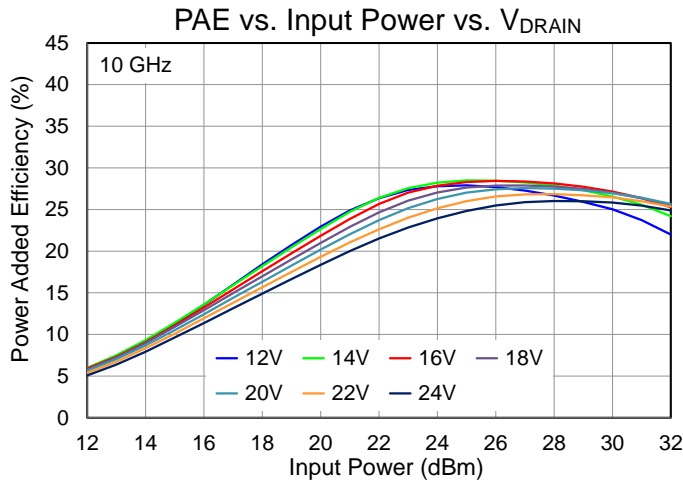
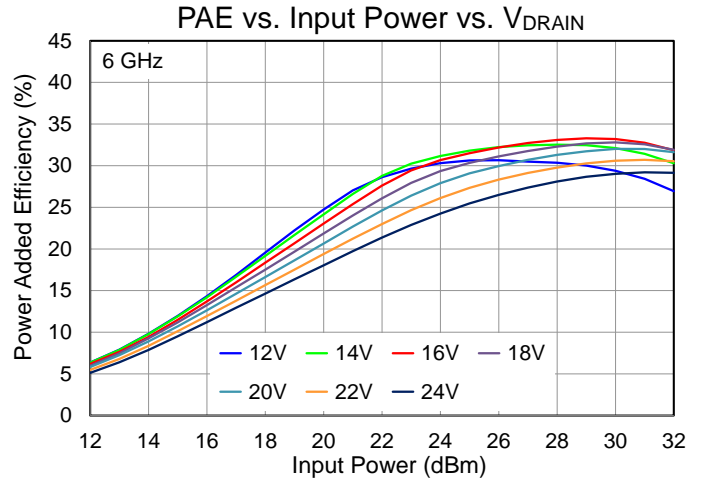
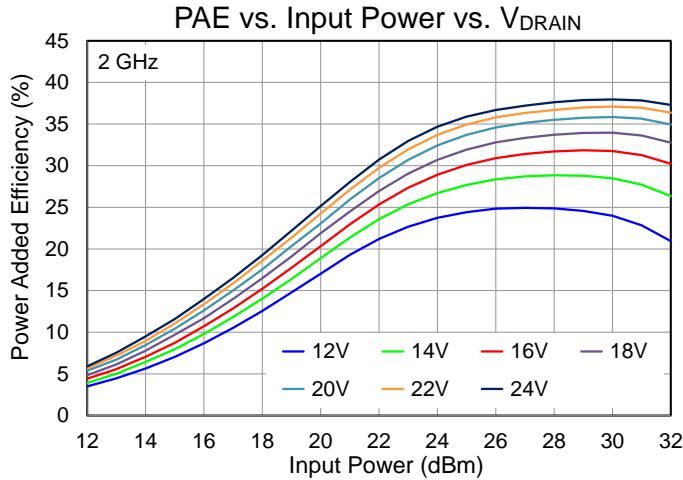

Performance Plots – Large Signal

Test conditions unless otherwise noted: CW,  $V_D = 22\text{ V}$ ,  $I_{DQ} = 1680\text{ mA}$ ,  $P_{IN} = 27\text{ dBm}$ ,  $T_{BASE} = +25\text{ }^\circ\text{C}$

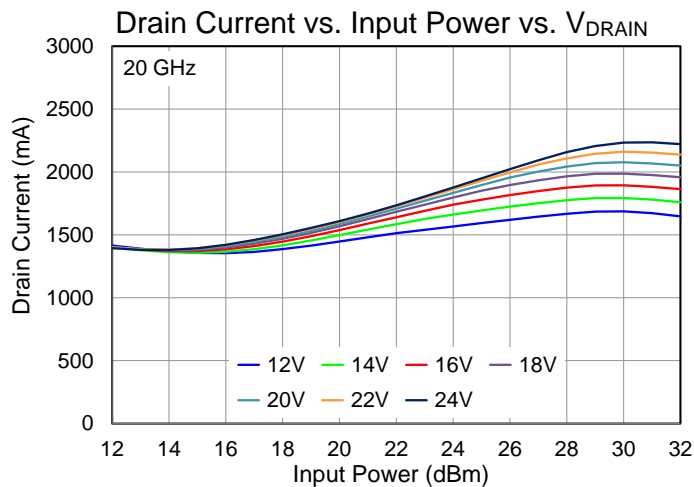
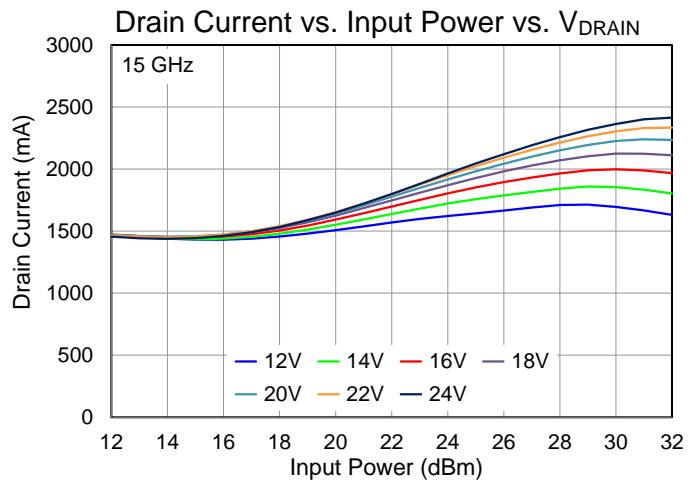
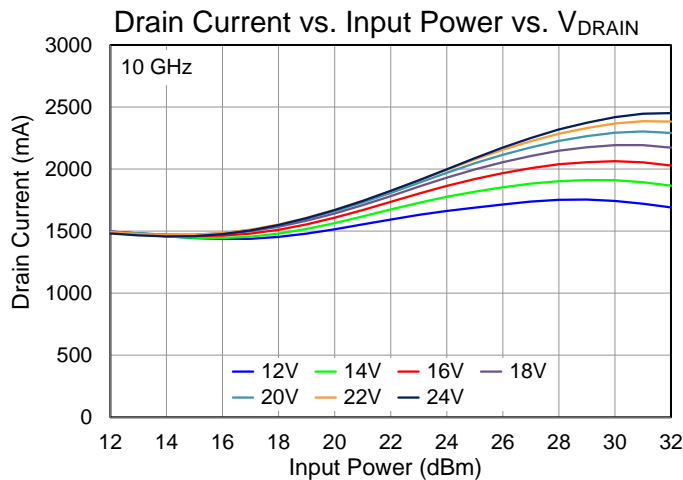
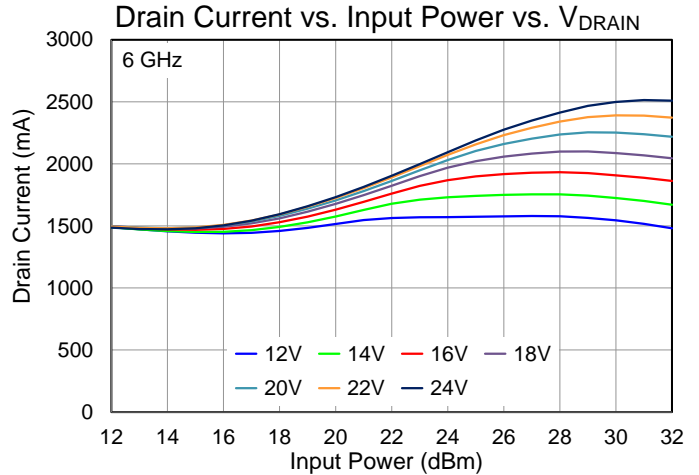
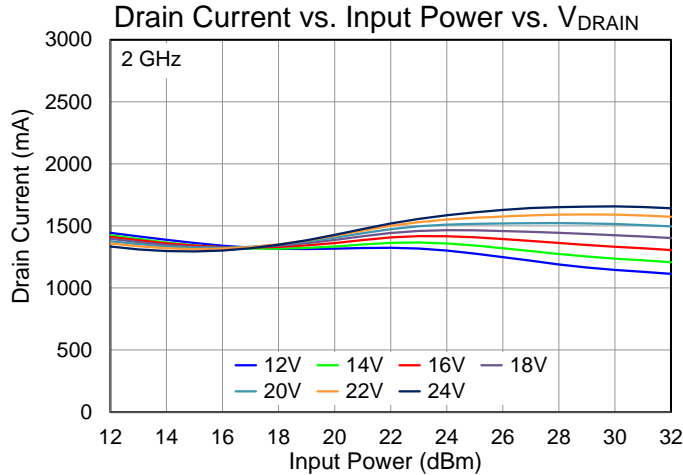

Performance Plots – Large Signal

Test conditions unless otherwise noted: CW,  $V_D = 22\text{ V}$ ,  $I_{DQ} = 1680\text{ mA}$ ,  $P_{IN} = 27\text{ dBm}$ ,  $T_{BASE} = +25\text{ }^\circ\text{C}$

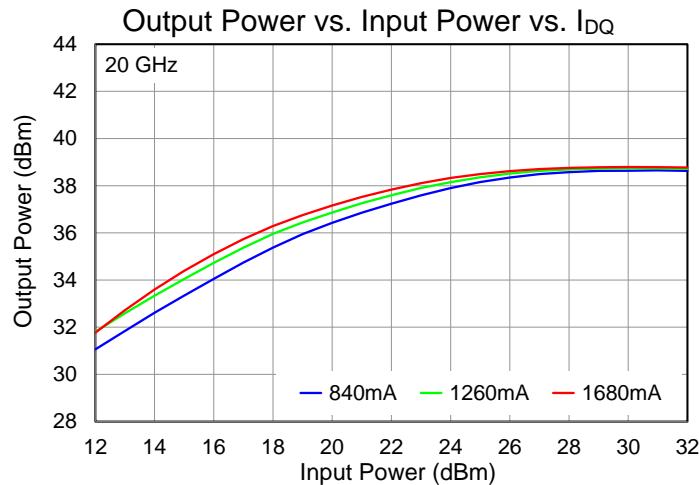
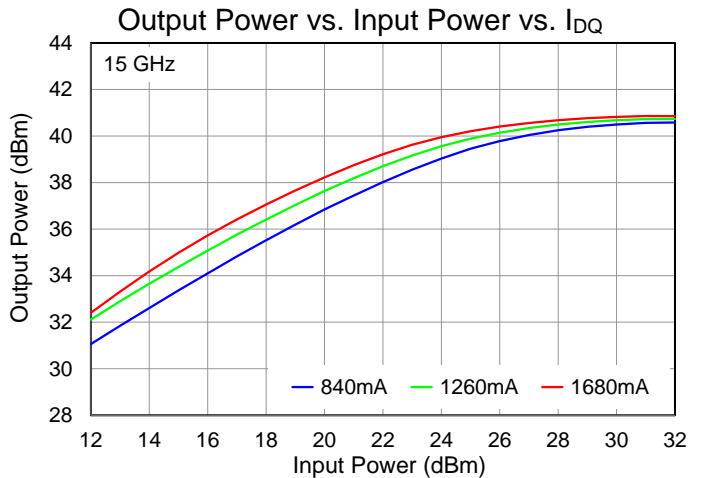
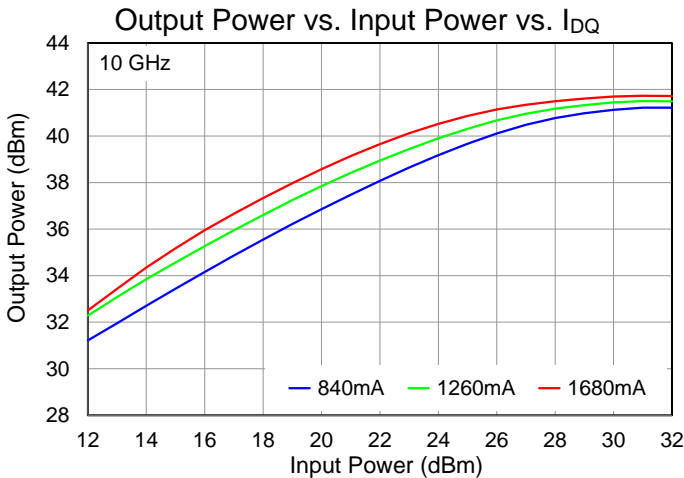
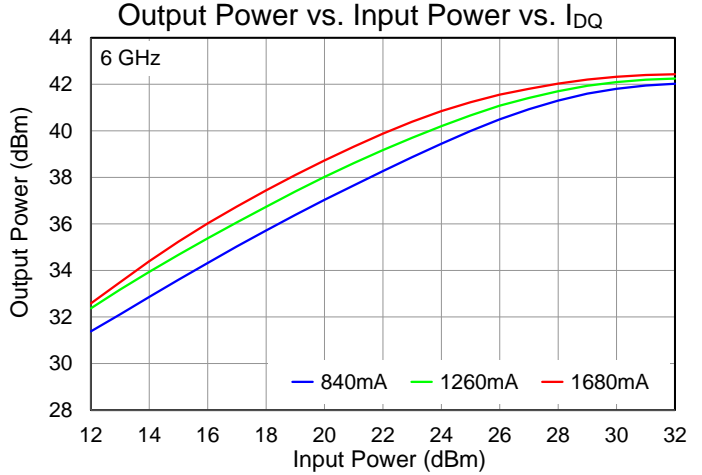
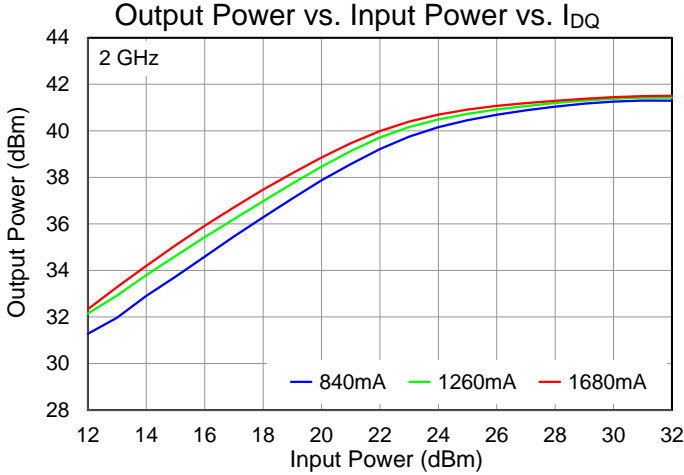

Performance Plots – Large Signal

Test conditions unless otherwise noted: CW,  $V_D = 22\text{ V}$ ,  $I_{DQ} = 1680\text{ mA}$ ,  $P_{IN} = 27\text{ dBm}$ ,  $T_{BASE} = +25\text{ }^\circ\text{C}$

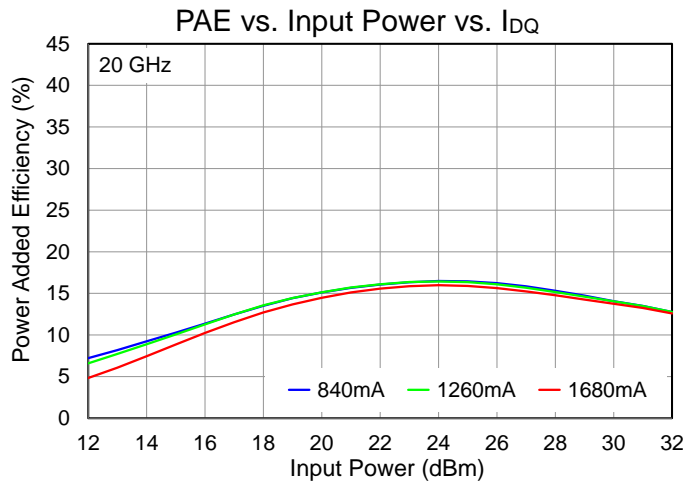
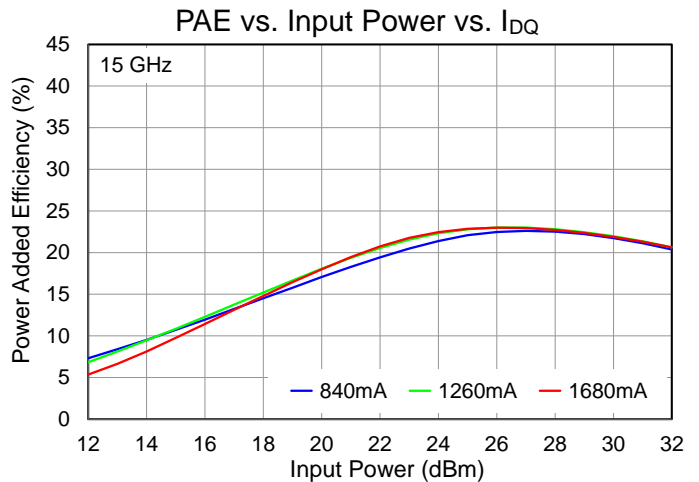
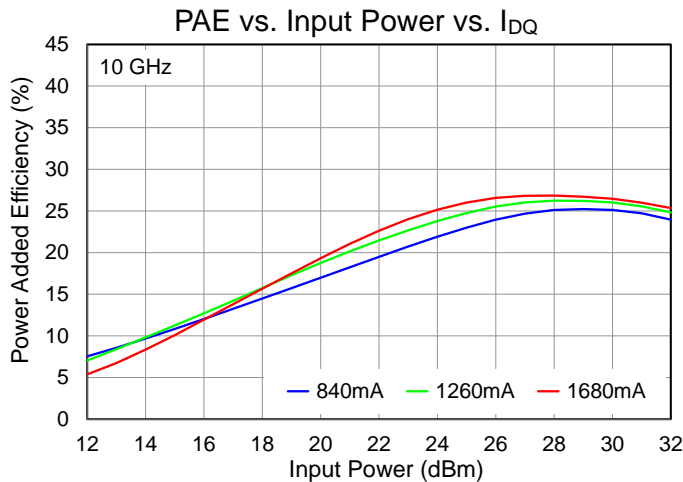
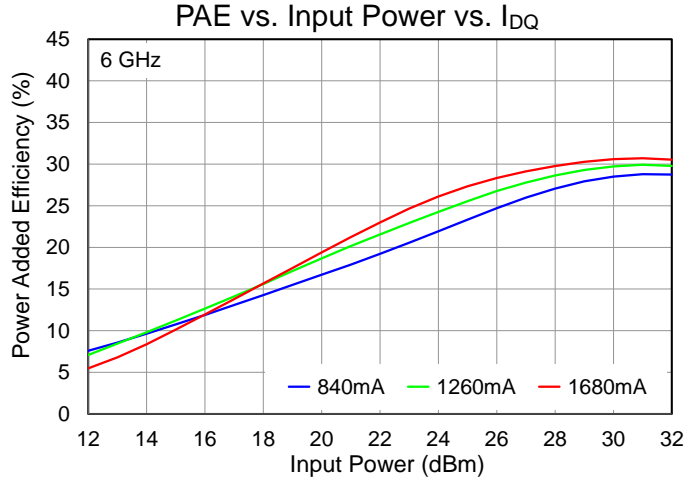
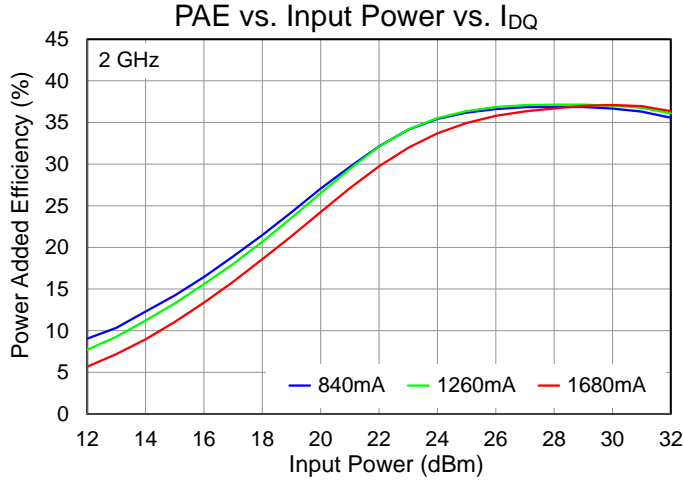

Performance Plots – Large Signal

Test conditions unless otherwise noted: CW,  $V_D = 22\text{ V}$ ,  $I_{DQ} = 1680\text{ mA}$ ,  $P_{IN} = 27\text{ dBm}$ ,  $T_{BASE} = +25\text{ }^\circ\text{C}$

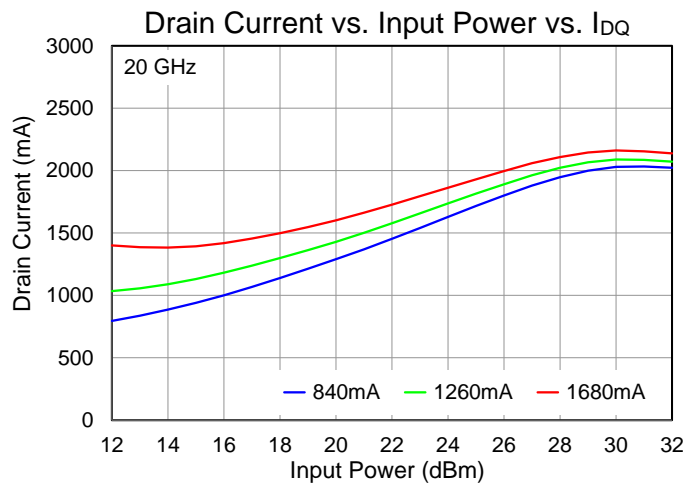
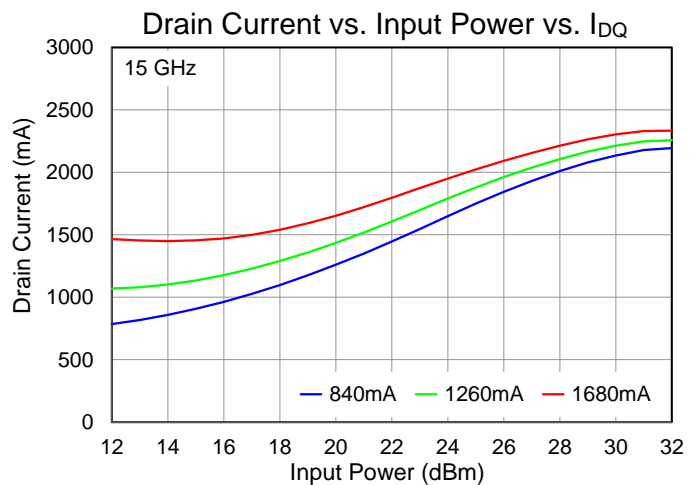
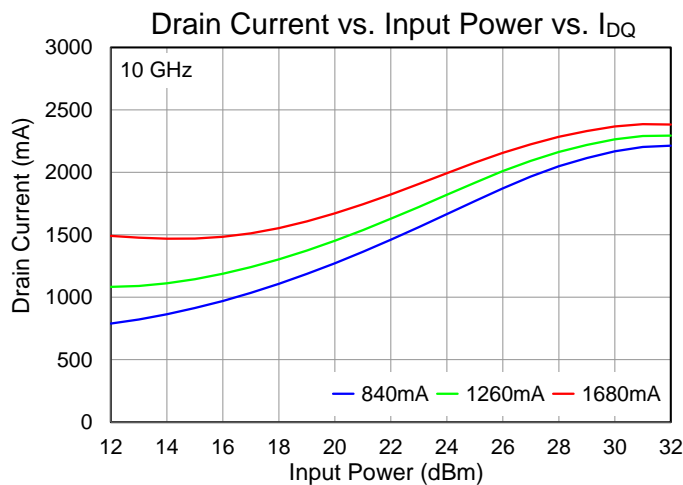
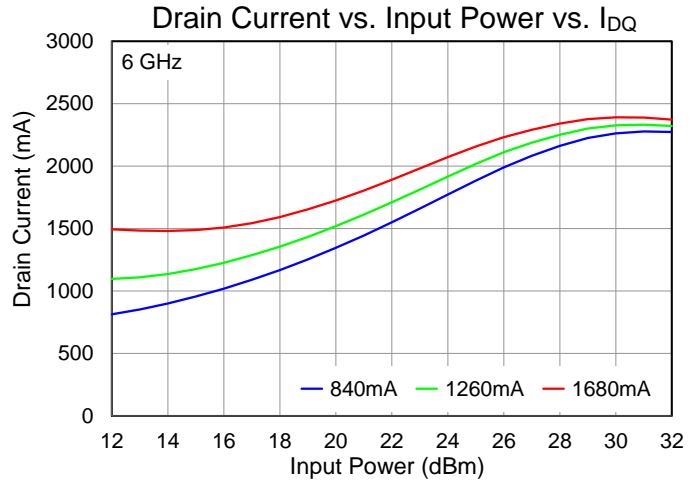
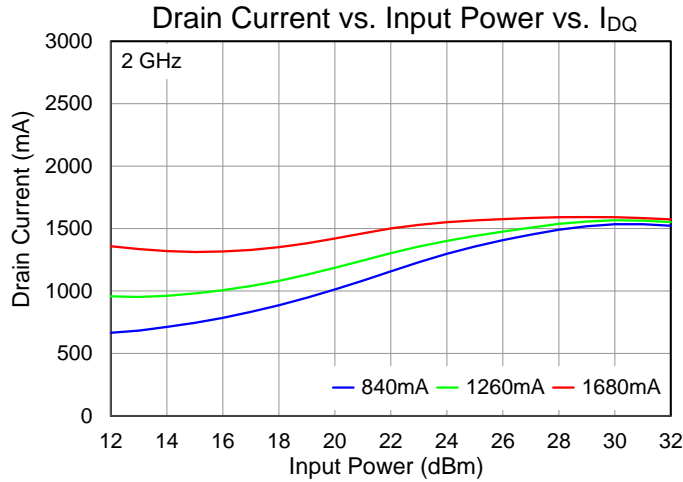



Performance Plots – Linearity

Test conditions unless otherwise noted: CW,  $V_D = 22\text{ V}$ ,  $I_{DQ} = 1680\text{ mA}$ , Tone Spacing = 100 MHz,  $T_{BASE} = +25\text{ }^\circ\text{C}$

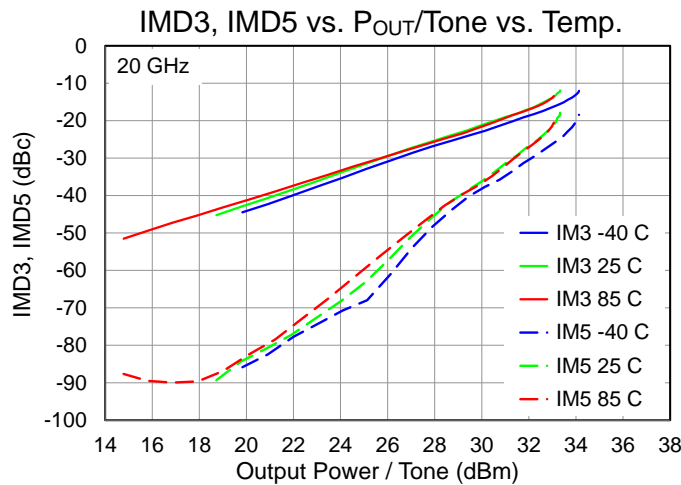
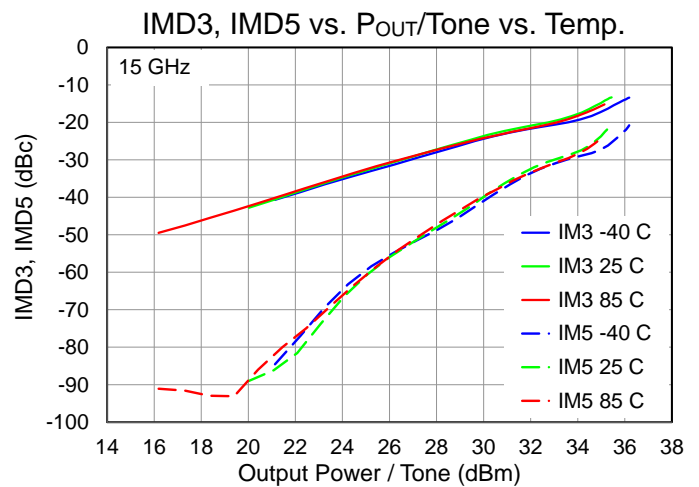
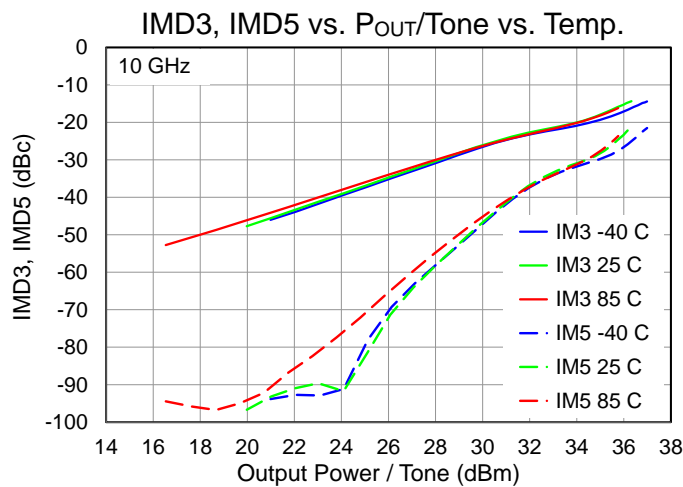
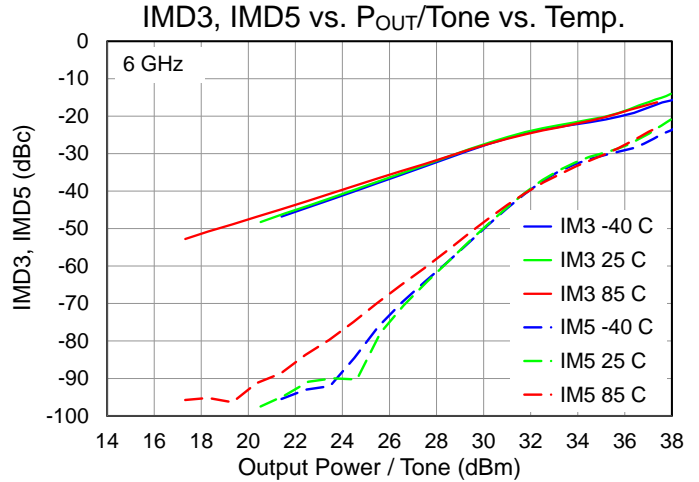
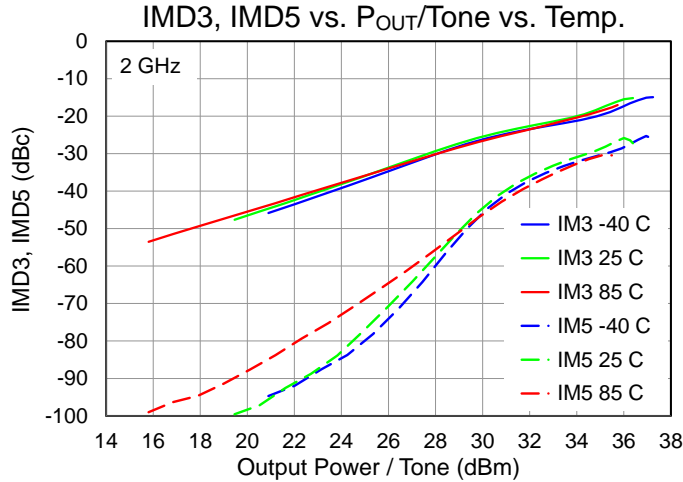

Performance Plots – Linearity

Test conditions unless otherwise noted: CW,  $V_D = 22\text{ V}$ ,  $I_{DQ} = 1680\text{ mA}$ , Tone Spacing = 100 MHz,  $T_{BASE} = +25\text{ }^\circ\text{C}$

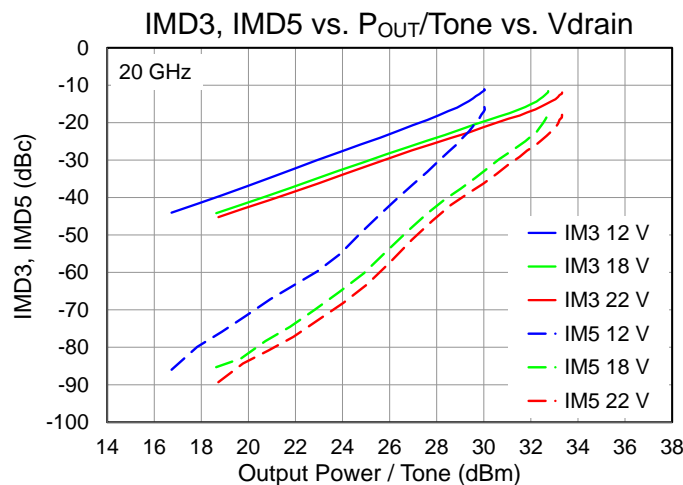
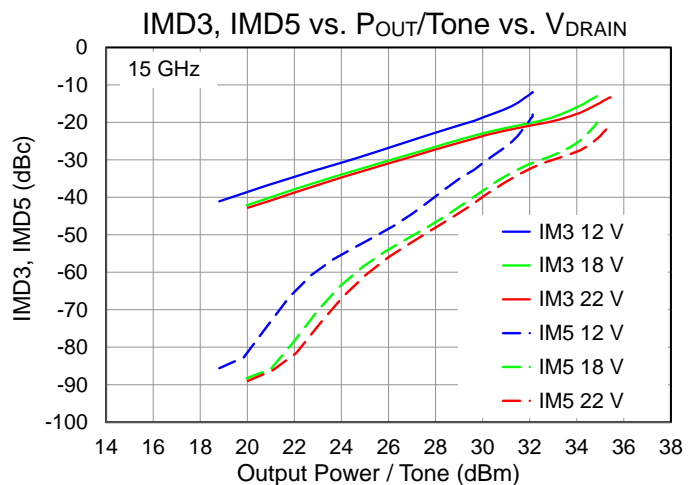
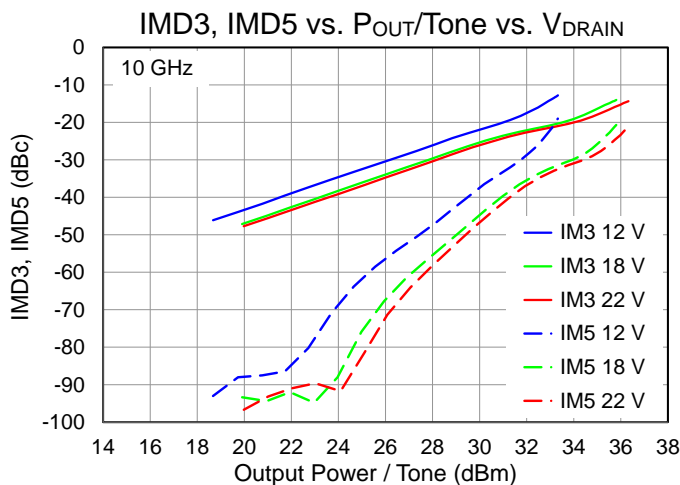
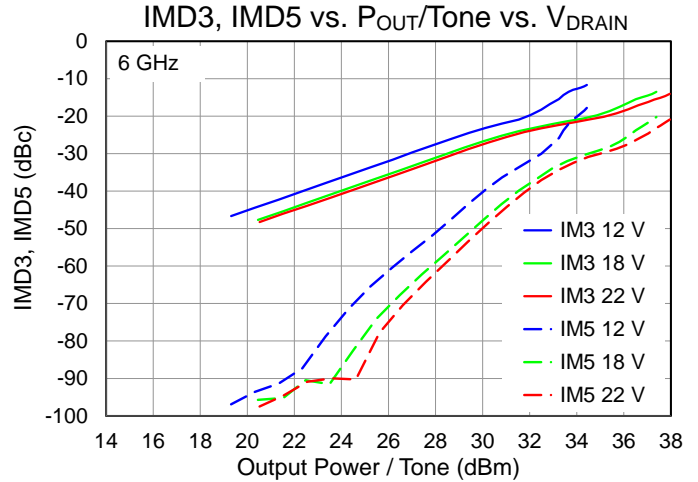
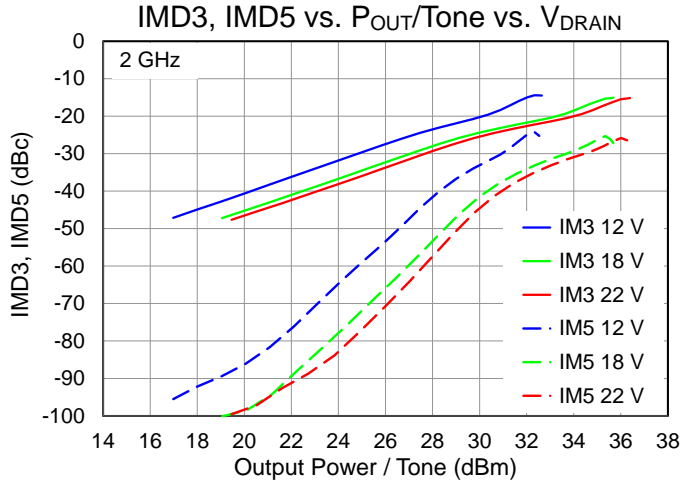

Performance Plots – Linearity

Test conditions unless otherwise noted: CW,  $V_D = 22\text{ V}$ ,  $I_{DQ} = 1680\text{ mA}$ , Tone Spacing = 100 MHz,  $T_{BASE} = +25\text{ }^\circ\text{C}$

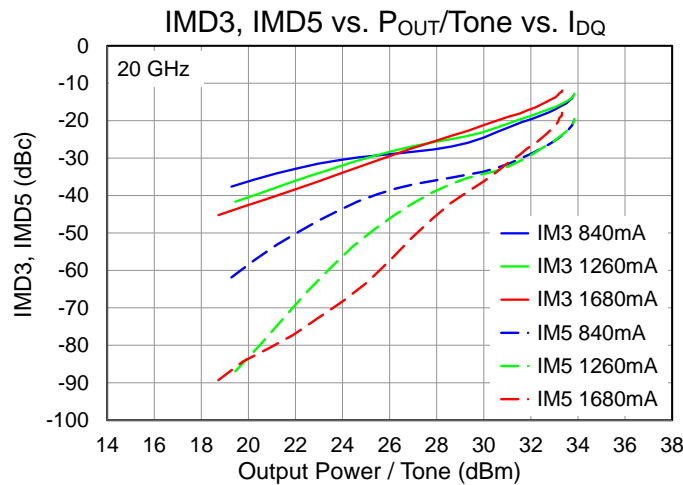
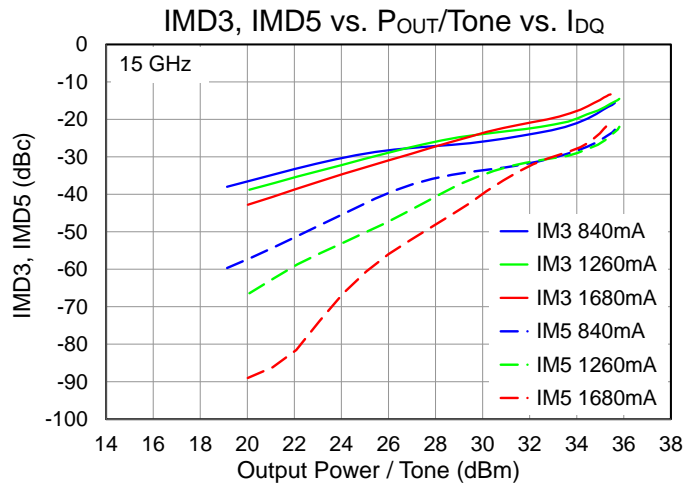
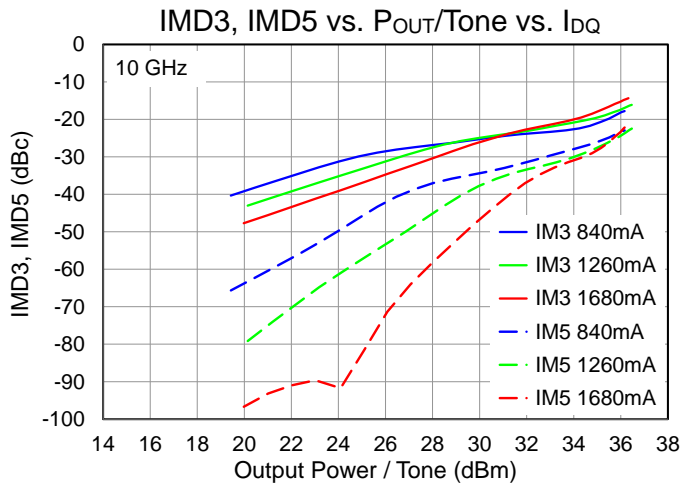
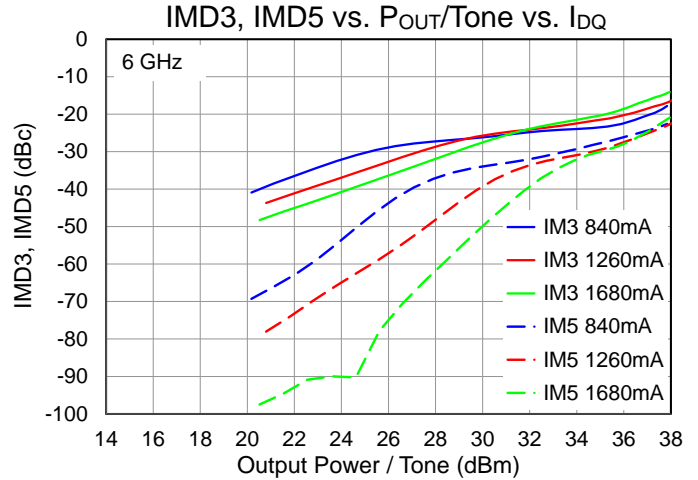
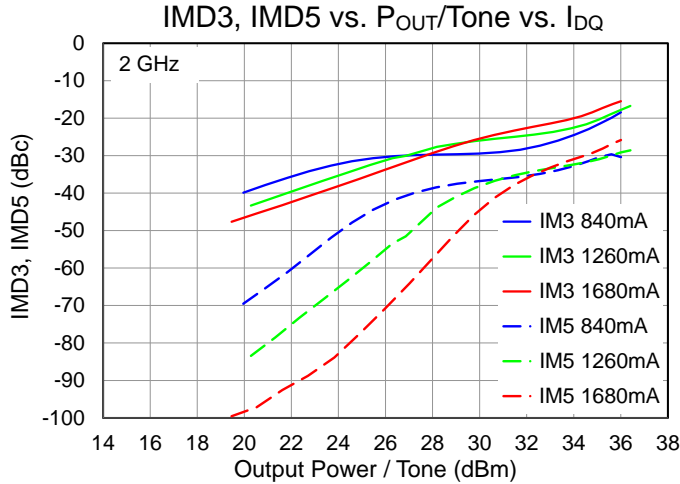

Performance Plots – Harmonics

Test conditions unless otherwise noted: CW,  $V_D = 22\text{ V}$ ,  $I_{DQ} = 1680\text{ mA}$ ,  $P_{IN} = 27\text{ dBm}$ ,  $T_{BASE} = +25\text{ }^\circ\text{C}$

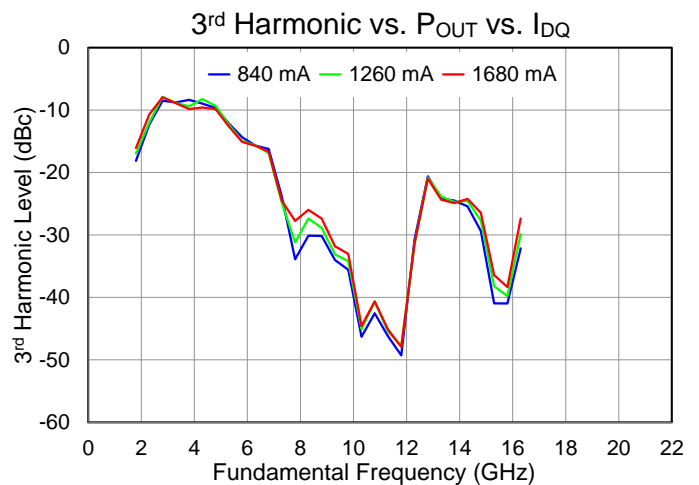
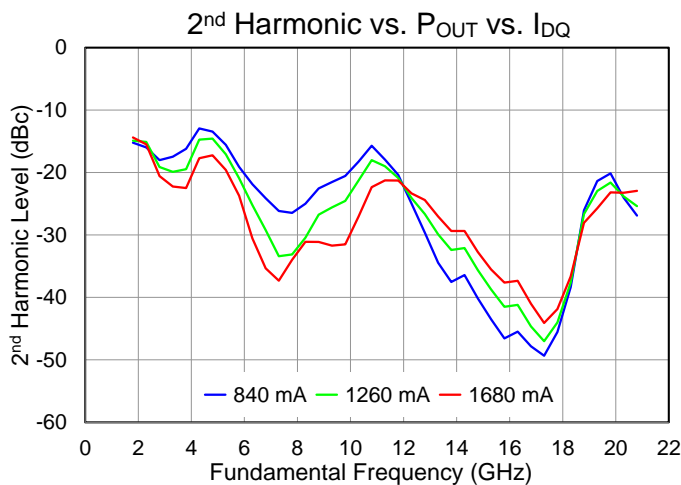
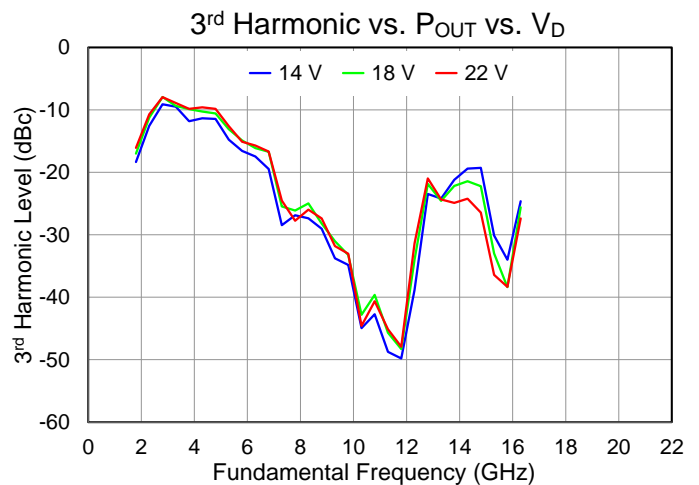
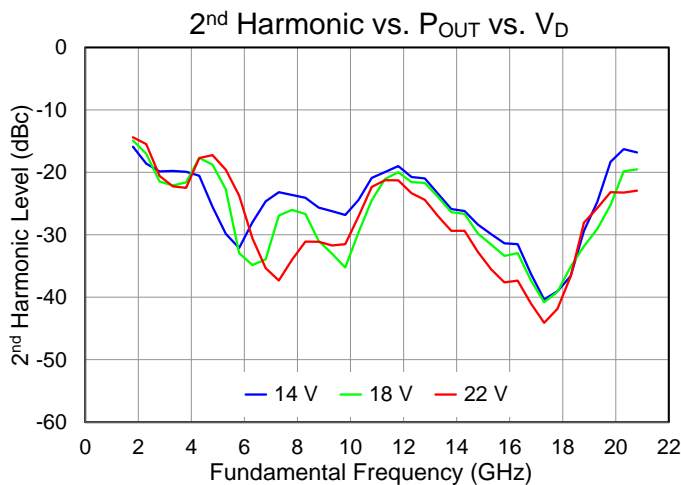
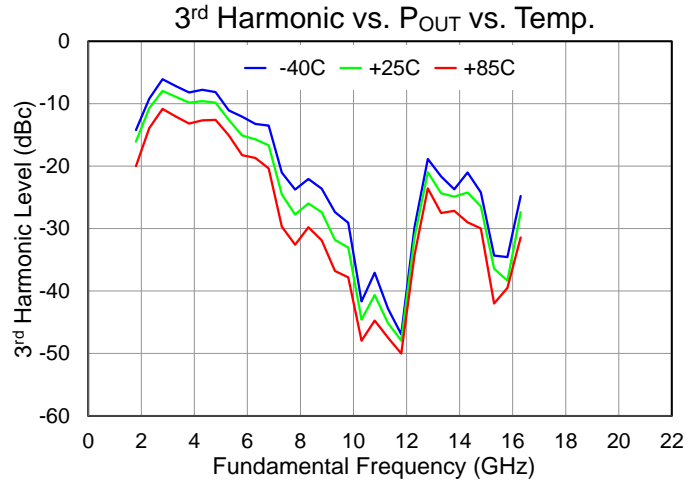
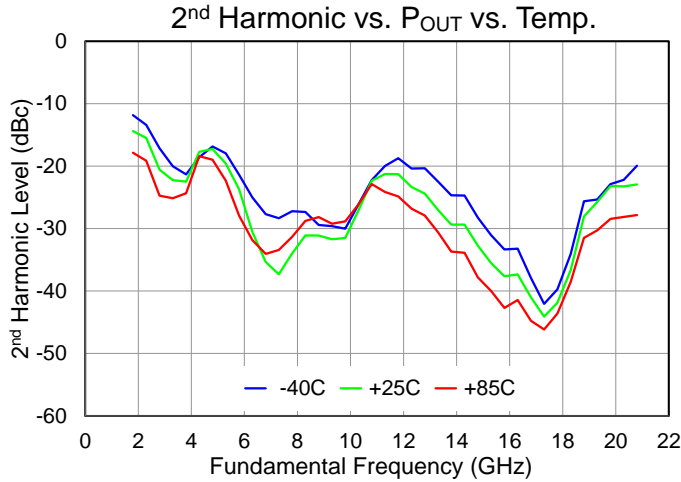

## Thermal and Reliability Information

Parameter	Test Conditions	Value	Units
Thermal Resistance ( $\theta_{JC}$ ) <sup>(1)</sup>	T <sub>BASE</sub> = 85 °C, V <sub>D</sub> = 22 V, I <sub>DQ</sub> = 1680 mA, No RF (quiescent DC operation)	2.83	°C/W
Channel Temperature, T <sub>CH</sub> (Under RF) <sup>(2)</sup>		189	°C
Thermal Resistance ( $\theta_{JC}$ ) <sup>(1)</sup>	T <sub>BASE</sub> = 85 °C, V <sub>D</sub> = 22 V, I <sub>DQ</sub> = 1680 mA, Freq = 19 GHz, I <sub>D_Drive</sub> = 2 A, P <sub>IN</sub> = 27 dBm, P <sub>OUT</sub> = 38.4 dBm,	2.82	°C/W
Channel Temperature, T <sub>CH</sub> (Under RF) <sup>(2)</sup>		191	°C

Notes:

1. Thermal resistance determined to the back of package (85 °C)
2. Channel temperature indicated is an IR scan equivalent temperature. Thermal resistance is calculated using this value. Additional information can be found in the Qorvo Applications Note “GaN Device TCHMAX Theta-JC and Reliability Estimates”, located here <https://www.qorvo.com/products/d/da006480>

## Dissipated Power

Test conditions, unless otherwise noted:  
V<sub>D</sub> = 22 V, I<sub>DQ</sub> = 1680 mA, T<sub>BASE</sub> = 25 °C, P<sub>IN</sub> = 27 dBm

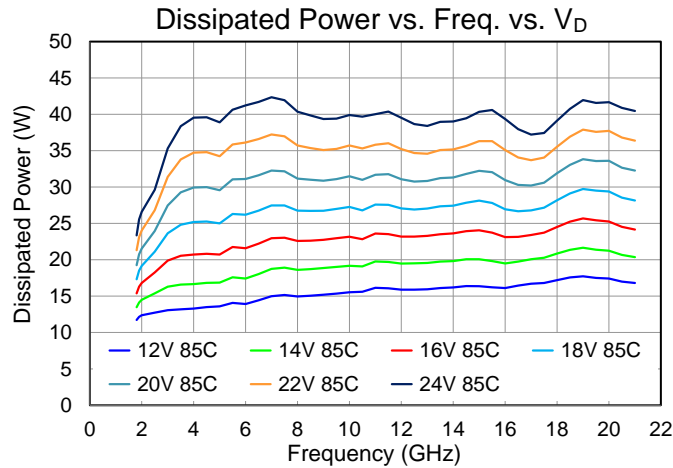

Applications Circuit (Pulse)

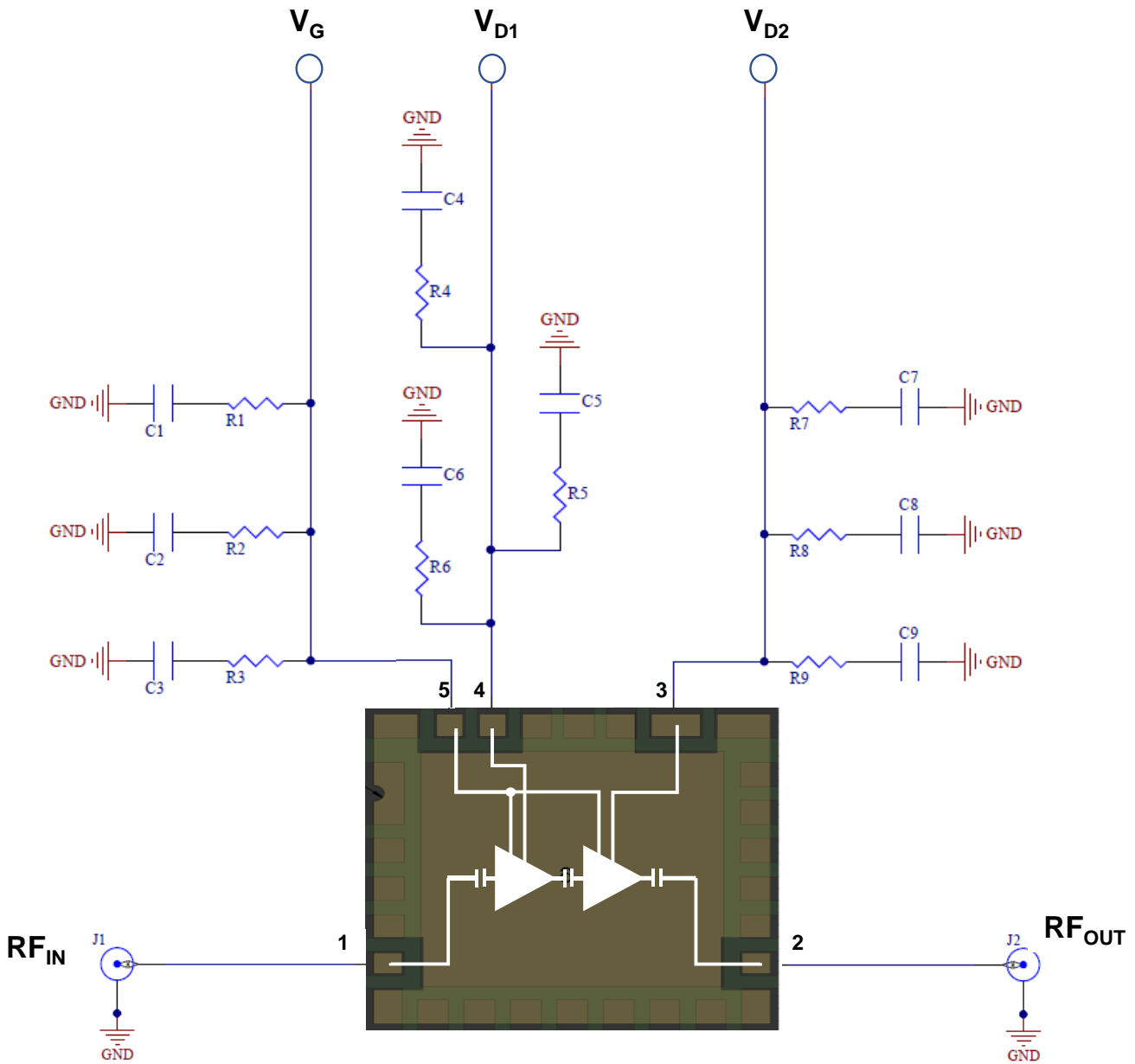

$V_{D1}$  and  $V_{D2}$  may be tied together

Bias-Up Procedure

1. Set  $I_D$  limit to 2840 mA,  $I_G$  limit to 10 mA
2. Set  $V_G$  to -4 V
4. Set  $V_D$  +22 V
5. Adjust  $V_G$  more positive until  $I_{DQ} = 1680$  mA
6. Apply RF signal

Bias-Down Procedure

1. Turn off RF signal
2. Reduce  $V_G$  to -4.0 V. Ensure  $I_{DQ} \sim 0$ mA
3. Set  $V_D$  to 0 V
4. Turn off  $V_D$  supply
5. Turn off  $V_G$  supply

Application Evaluation Board

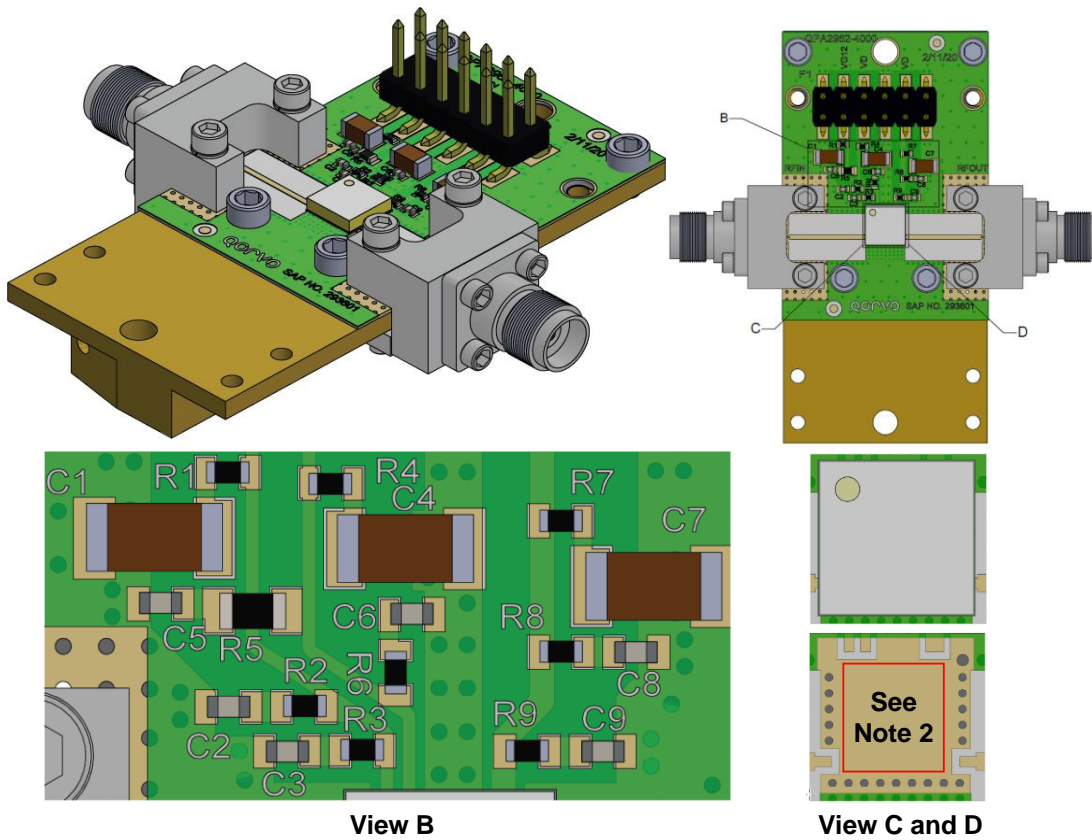

Notes:

1. RF PCB is Rogers 6035HTC, 0.010" thick; copper cladding is ½ oz. copper both sides, plated to 1 oz
2. Populated with high density vias; vias are to be non-conductive epoxy filled, over-plated, and planarized

Bill of Materials

Reference Des.	Value	Description	Manuf.	Part Number
C1, C4, C7	10 uF	CAP, 10uF, ±20%, 50V, X5R, 1206	Various	
C2, C3, C5, C6, C8, C9	0.1 uF	CAP, 0.1uF, ±10%, 50V, X7R, 0402	Various	
R2, R3, R6, R7, R8, R9	0 Ω	RES, 0 OHM, JMPR, 0402	Various	
R1, R4	10 Ω	RES, 5.1 OHM, 5%, 50V, 0402	Various	
R5	0 Ω	RES, 0 OHM, 0.1W, 0603	Various	
H1	-	Header, connector, 2x6, 0.100", SMD		
J1, J2	-	Connector, Female, End Launch, 2.9mm	Southwest Microwave	1092-01A-5
S1 – S4	-	Screw, cap, socket head, 2-56x1/8"		
PCB	-	Rogers 4003C, 8 mil dielectric, 1 oz. copper (gold plated), 2 layers	Rogers Corp.	Custom
Carrier	-	T-Carrier, Copper C110, 0.990 x 2.000 x 0.275"		Custom
Solder	-	Paste, solder, syntech, Sn62/Pb36/Ag2		

## Mechanical Information

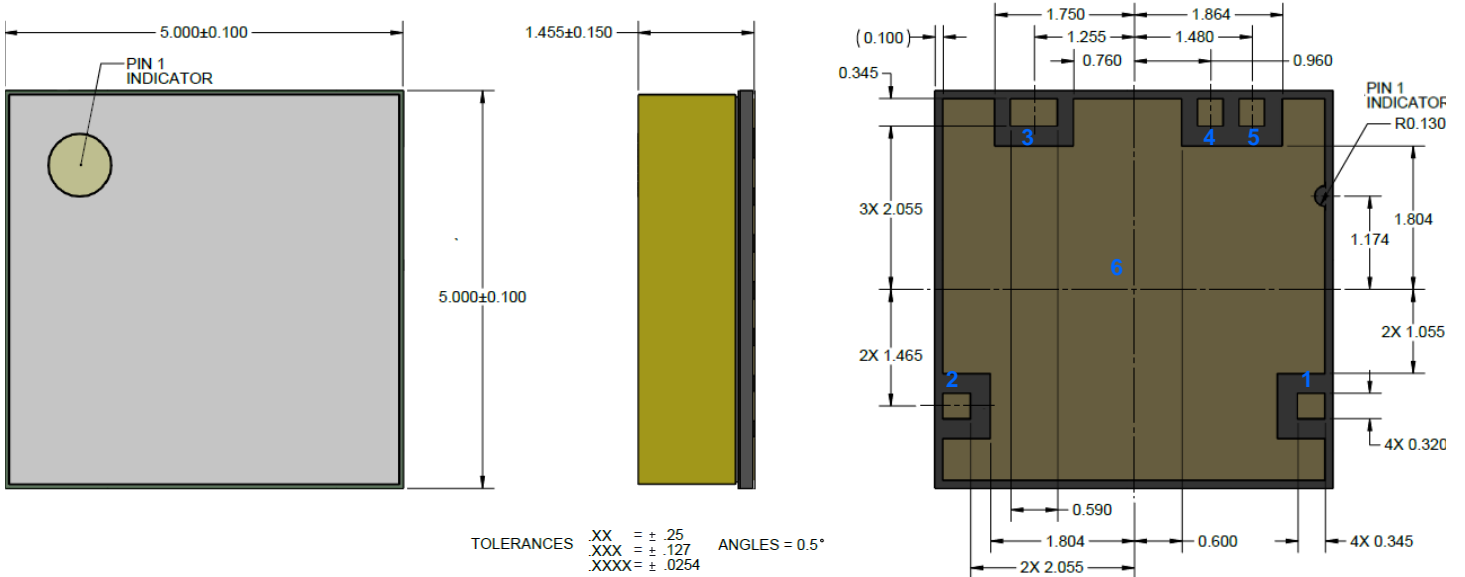

Notes: unless otherwise specified;

1. Dimensions: millimeters (mm)
2. Package is air cavity, leads are gold (Au) plated, base is laminate; Part is epoxy sealed
3. Marking: YY is calendar year; WW is assembly week; MXXX is batch ID

## Pin Description

Pin Number	Symbol	Description
1	RF <sub>IN</sub>	RF input. 50 Ohms. DC blocked.
2	RF <sub>OUT</sub>	RF output. 50 Ohms. DC blocked.
3	V <sub>D2</sub>	Drain voltage, stage 2. Bypass network required; refer to page 22.
4	V <sub>D1</sub>	Drain voltage, stage 1. Bypass network required; refer to page 22.
5	V <sub>G</sub>	Gate voltage, stage 1 and 2. Bypass network required; refer to page 22.
6	Center Pad	Ground connection
Non-assigned pins		Ground. Connect to PCB ground



Tape and reel Information

Standard T/R size = 250 pieces on a 7" reel

Dimensions: millimeters (mm)

Tolerances unless otherwise noted: .X = ± .2; .XX = ± .10

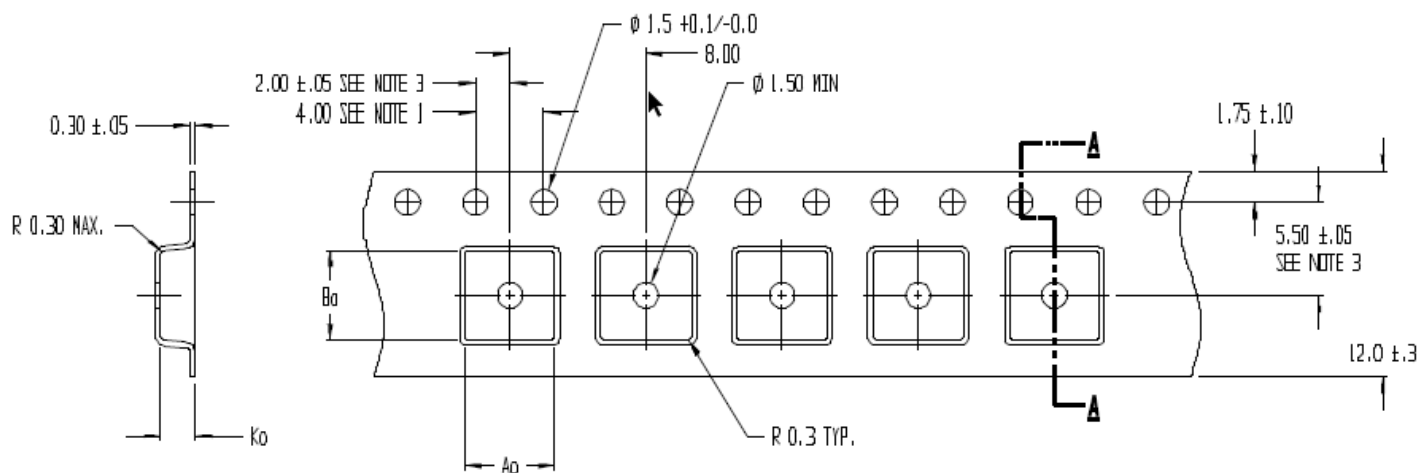

A<sub>0</sub> = 5.30  
B<sub>0</sub> = 5.30  
K<sub>0</sub> = 2.00

NOTES:

1. 10 SPROCKET HOLE PITCH CUMULATIVE TOLERANCE ±0.2
2. CAMBER IN COMPLIANCE WITH EIA 481
3. POCKET POSITION RELATIVE TO SPROCKET HOLE MEASURED AS TRUE POSITION OF POCKET, NOT POCKET HOLE

### Solderability

Compatible with lead-free soldering processes with 260°C peak reflow temperature.

This package is air-cavity and non-hermetic, and therefore cannot be subjected to aqueous washing. The use of no-clean solder to avoid washing after soldering is highly recommended.

Contact plating: Ni-Au

Solder rework not recommended

### Recommended Soldering Temperature Profile

