

Product Overview

The Qorvo® QPA5219 is a three-stage power amplifier (PA) designed for Wi-Fi 5. The compact form factor and integrated matching minimizes layout area in the application.

Performance is focused on optimizing for power consumption while maintaining the highest linear output power and leading edge throughput that leads to greater ranges.

The design significantly minimizes external component needs leading to a simplified board implementation and more consistent performance at a system level over a variety of conditions

The QPA5219 integrates a 2.4 GHz power amplifier (PA), regulator and a power detector for improved accuracy.



16 Pin 3x3 mm Laminate Package

Key Features

- 2400-2500 MHz
- P_{OUT} = +24dBm MCS8/9 VHT20/40 -35dB Dynamic EVM
- P_{OUT} = +25dBm MCS7 HT20 -30dB Dynamic EVM
- P_{OUT} = +26dBm 802.11g -28dB Dynamic EVM
- P_{OUT} = +28.5dBm 802.11b @ Spectral Mask Compliance
- Optimized for +5 V Operation
- 32 dB Tx Gain
- Integrated DC Power Detector
- MCS11 and 3.3V Capable

Functional Block Diagram

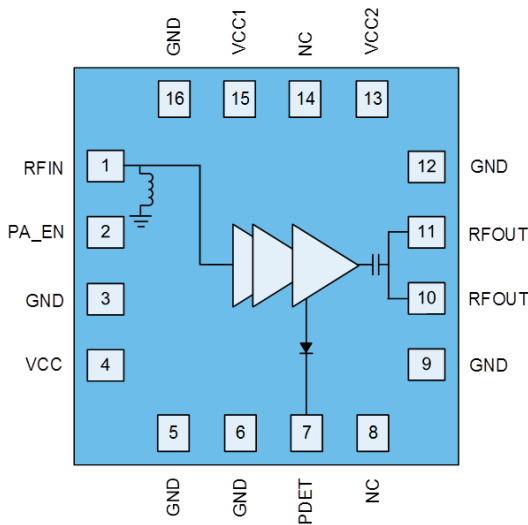

Top View

Applications

- Access Points
- Wireless Routers
- Client Equipment
- Customer Premise Equipment
- Internet of Things

Ordering Information

Part Number	Description
QPA5219SB	Sample bag with 5 pieces
QPA5219SR	7" reel with 100 pieces
QPA5219TR13	13" reel with 5000 pieces
QPA5219EVB	Assembled Evaluation Board

Handling Precautions

Parameter	Rating	Standard
ESD – Human Body Model (HBM)	Class 1C	ANSI/ESD/JEDEC JS-001
ESD – Charged Device Model (CDM)	Class C3	ANSI/ESD/JEDEC JS-002
MSL – Moisture Sensitivity Level	Level 3	IPC/JEDEC J-STD-020



Caution!

ESD sensitive device

Solderability

Compatible with both lead-free (260 °C max. reflow temperature) and tin/lead (245 °C max. reflow temperature) soldering processes.

Package lead plating: Electrolytic plated Au over Ni

RoHS Compliance

This part is compliant with the 2011/65/EU RoHS directive (Restrictions on the Use of Certain Hazardous Substances in Electrical and Electronic Equipment), as amended by Directive 2015/863/EU.

This product also has the following attributes:

- Lead free
- Halogen Free (Chlorine, Bromine)
- Antimony Free
- TBBP-A (C₁₅H₁₂Br₄O₂) Free
- SVHC Free



Contact Information

For the latest specifications, additional product information, worldwide sales and distribution locations:

Web: www.qorvo.com

Tel: 1-844-890-8163

Email: customer.support@qorvo.com

Important Notice

The information contained herein is believed to be reliable; however, Qorvo makes no warranties regarding the information contained herein and assumes no responsibility or liability whatsoever for the use of the information contained herein. All information contained herein is subject to change without notice. Customers should obtain and verify the latest relevant information before placing orders for Qorvo products. The information contained herein or any use of such information does not grant, explicitly or implicitly, to any party any patent rights, licenses, or any other intellectual property rights, whether with regard to such information itself or anything described by such information. **THIS INFORMATION DOES NOT CONSTITUTE A WARRANTY WITH RESPECT TO THE PRODUCTS DESCRIBED HEREIN, AND QORVO HEREBY DISCLAIMS ANY AND ALL WARRANTIES WITH RESPECT TO SUCH PRODUCTS WHETHER EXPRESS OR IMPLIED BY LAW, COURSE OF DEALING, COURSE OF PERFORMANCE, USAGE OF TRADE OR OTHERWISE, INCLUDING THE IMPLIED WARRANTIES OF MERCHANTABILITY AND FITNESS FOR A PARTICULAR PURPOSE.**

Without limiting the generality of the foregoing, Qorvo products are not warranted or authorized for use as critical components in medical, life-saving, or life-sustaining applications, or other applications where a failure would reasonably be expected to cause severe personal injury or death.

Copyright 2020 © Qorvo, Inc. | Qorvo is a registered trademark of Qorvo, Inc.