

### Product Description

The QPA5368 is an Integrated Reverse Amplifier Module. The part employs Silicon Bipolar die, has high output capability and is operated from 5 MHz to 300 MHz. It provides excellent linearity and superior return loss performance with low noise and optimal reliability.

### Functional Block Diagram

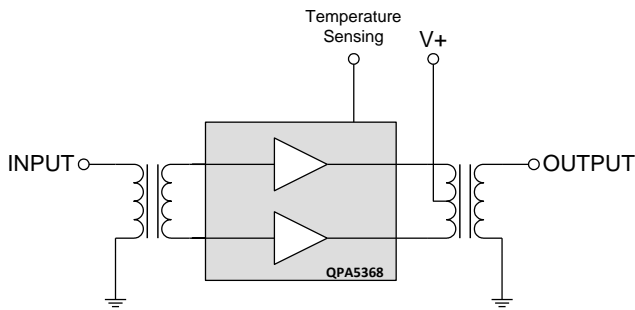

20 pin, 11.0 mm x 8.5 mm x 1.375 mm package

### Product Features

- Excellent Linearity
- Extremely High Output Capability
- Superior Return Loss Performance
- Extremely Low Distortion
- Optimal Reliability
- Low Noise
- Unconditionally Stable under all Terminations
- 35.6 dB Typical Gain at 300MHz
- 195 mA Typical at 12VDC
- Temperature Sensing Feature

### Applications

- Head End Equipment
- 5–300 MHz 75  $\Omega$  Amplifier for Reverse Path Systems

### Ordering Information

Part No.	Description
QPA5368SB	Sample bag 5 pcs
QPA5368SR	7" Reel with 100 pcs
QPA5368TR7	7" Reel with 500 pcs
QPA5368PCBA-410	Fully assembled Evaluation Board

## Absolute Maximum Ratings

Parameter	Value / Range
RF Input Voltage (single tone)	65 dBmV
DC Supply over-voltage (5 minutes)	+14 V
Storage Temperature	-40 to 100 °C
Operating Mounting Base Temperature	-30 to 100 °C
Moisture Sensitivity Level IPC/JEDEC J-STD-20	MSL 3 @ 260 °C

Operation of this device outside the parameter ranges given above may cause permanent damage.

## Electrical Specifications –

Parameter	Conditions (V+=12V, TMB=30°C, ZS=ZL=75Ω)	Min	Typ	Max	Units
Operational Frequency Range	–	5	–	300	MHz
Current (I <sub>DD</sub> )	–	180	195	210	mA
Gain	f <sub>o</sub> = 5 MHz		35.3		dB
Gain	f <sub>o</sub> = 300 MHz	34.8	35.6	36.5	
Gain Flatness	5 to 300 MHz	–		1.0	
Gain Slope	5 to 300 MHz <sup>[1]</sup>	-0.2	+0.3	1.0	
Input Return Loss	f <sub>o</sub> = 5 to 220 MHz	20		–	dB
	f <sub>o</sub> = 220 to 300 MHz	18		–	
Output Return Loss	f <sub>o</sub> = 5 to 220 MHz	20		–	dB
	f <sub>o</sub> = 220 to 300 MHz	18		–	
Noise Figure	f <sub>o</sub> = 300 MHz	–	3.9	4.1	dB
CTB				-72	dBc
XMOD	7 ch flat; V <sub>o</sub> = 50 dBmV <sup>[2]</sup>			-63	dBc
CSO				-75	dBc
CTB				-65	dBc
XMOD	28 ch flat; V <sub>o</sub> = 46 dBmV <sup>[3]</sup>			-58	dBc
CSO				-70	dBc
CTB			-62	-59	dBc
XMOD	42 ch flat; V <sub>o</sub> = 44 dBmV <sup>[4]</sup>		-62	-59	dBc
CSO			-65	-62	dBc
OIP2	V <sub>o</sub> = 11 dBm <sup>[5]</sup>		70		dBm
OIP3	V <sub>o</sub> = 11 dBm <sup>[6]</sup>		44		dBm
Thermal Resistance	Junction to Mounting Base		25		K/W

- The slope is defined as the difference between the gain at the start frequency and the gain at the stop frequency.
- 7 channels, NTSC frequency raster: T7-T13 (7.0MHz to 43.0MHz), +50dBmV flat output level.
- 28 channels, NTSC frequency raster: T7-T13 (7.0MHz to 43.0MHz), 2-6 (55.25MHz to 83.25MHz), A-11 (121.25MHz to 199.25MHz), +46dBmV flat output level.
- 42 channels, NTSC frequency raster: T7-T13 (7.0MHz to 43.0MHz), 2-6 (55.25MHz to 83.25MHz), A-W (121.25MHz to 295.25MHz), +44dBmV flat output level.
- 2-tone, 11dBm/tone, f1=99.0MHz, f2=100.0MHz, 1 MHz tone spacing, fm=199.0MHz (f1+f2)
- 2-tone, 11dBm/tone, f1=199.0MHz, f2=200.0MHz, 1 MHz tone spacing, fm=201.0MHz (2xf2-f1)

Composite Second Order (CSO) - The CSO parameter (both sum and difference products) is defined by ANSI/SCTE 6. Composite Triple Beat (CTB) The CTB parameter is defined by ANSI/SCTE 6. Cross Modulation (XMOD) - Cross modulation (XMOD) is measured at baseband (selective voltmeter method), referenced to 100% modulation of the carrier being tested. Carrier to Intermodulation Noise (CIN) - The CIN parameter is defined by ANSI/SCTE 17 (Test procedure for carrier to noise).

Evaluation Board Assembly Drawing

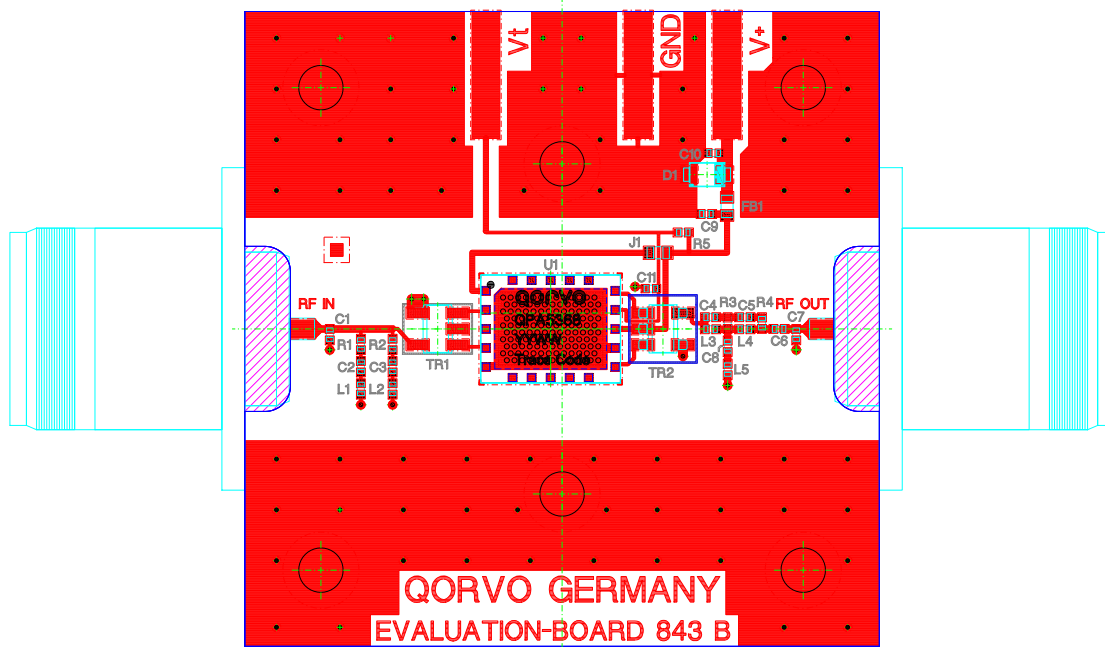

Evaluation board PCB: FR4, double sided, 1.5mm, 35um Cu

Vias are required under the backside paddle of this device for proper RF/DC grounding and thermal dissipation. A via drill diameter of 0.4mm and a minimum via wall copper plating thickness of 25um is recommended. Open vias are preferred to allow flux and gases to escape during reflow soldering and therefore to minimize voiding. Underneath this via array a heat sink with thermal grease needs to be placed which is able to dissipate the complete module DC power (up to 2.5 Watts). In any case the module backside temperature should not exceed 100 °C.

Evaluation Board Schematic

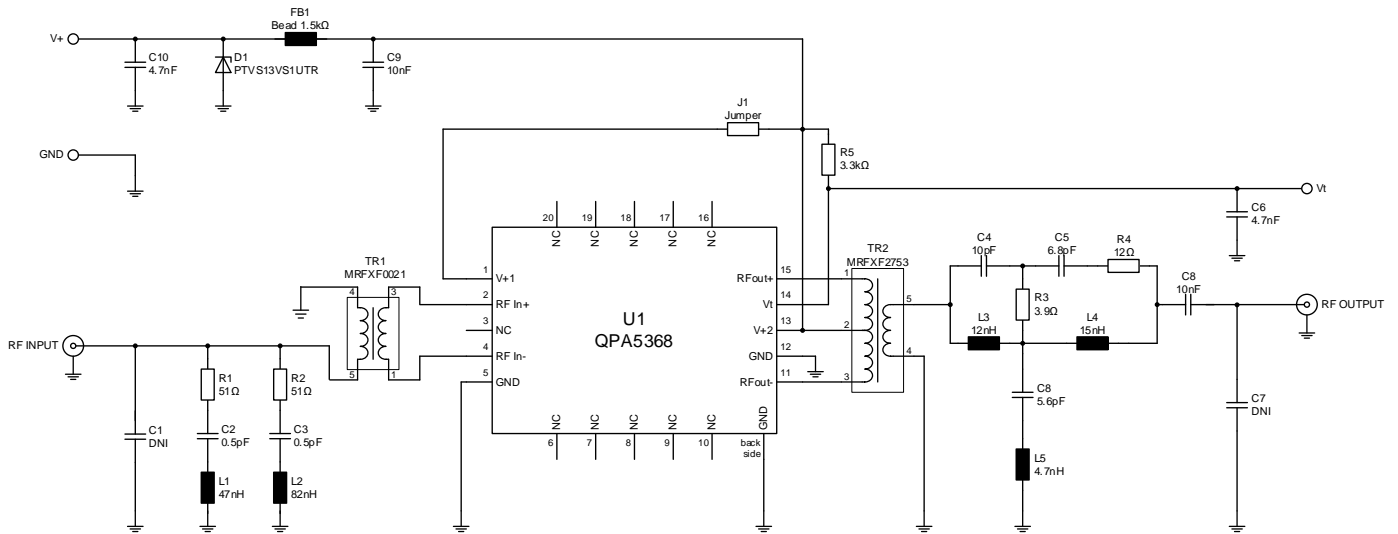

## Evaluation Board Bill of Materials (BOM)

Reference Des.	Value	Description	Manuf.	Part Number
PCB	Rev A	PCB QPA5368 – EVB 843B	Qorvo	
C1, C7		DNI (optional to improve matching)		
C2, C3	0.5 pF	CAP, 0402, $\pm 0.1$ pF, 50V, COG		
C4	10 pF	CAP, 0402, 5%, 50V, COG		
C5	6.8 pF	CAP, 0402, 5%, 50V, COG		
C6, C9	10 nF	CAP, 0402, 10%, 50V, X7R		
C8	5.6 pF	CAP, 0402, $\pm 0.25$ pF, 50V, COG		
C10, C11	4.7 nF	CAP, 0402, 10%, 50V, X7R		
R1, R2	51 $\Omega$	RES, 0402, 1%, TK100		
R3	3.9 $\Omega$	RES, 0402, 1%, TK100		
R4	12 $\Omega$	RES, 0402, 1%, TK100		
R5	3.3 k $\Omega$	RES, 0402, 1%, TK100		
J1	0 $\Omega$	RES, 0603		
L1	47 nH	IND, 0402, 5%		
L2	82 nH	IND, 0402, 5%		
L3	12 nH	IND, 0402, 5%		
L4	15 nH	IND, 0402, 5%		
L5	4.7 nH	IND, 0402, $\pm 0.3$ nH		
FB1	1,5 k $\Omega$	Impedance Bead, 0603, 1k5 @ 100MHz, LM, DCR 0.75 $\Omega$ , 250mA	TaiyoYuden	BK 1608 LM 152
D1	13 V	Diode, TVS, PTVS13VS1UR, SOD123W	NXP	PTVS13VS1UR
TR1		Transformer 1:1	Mini-RF	MRFXF0021
TR1		Transformer 1:4	Mini-RF	MRFXF2753
U1	DUT	QPA5368	Qorvo	

Notes:

## Pin Configuration

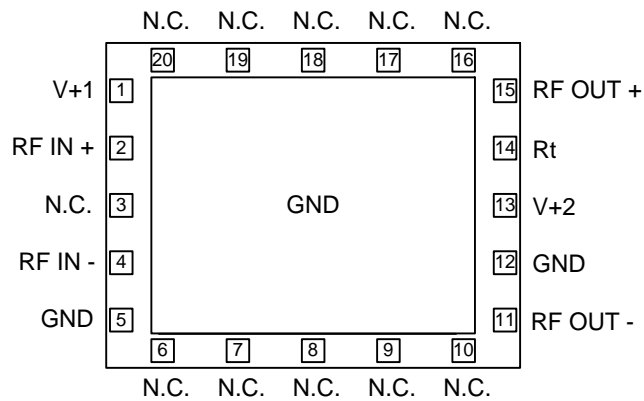

## Pin Description

Pin No.	Label	Description
1	V+ 1	Supply Voltage 12V
2	RF IN (+)	RF AMP Positive Input
3	N.C.	
4	RF IN (-)	RF AMP Negative Input
5	GND	RF/DC ground
6 - 10	N.C.	
11	RF OUT (-)	RF AMP Negative Output
12	GND	RF/DC ground
13	V+ 2	Supply Voltage 12V
14	Rt	NTC Output for Temperature Sensing
15	RF OUT (+)	RF AMP Positive Output
16-20	N.C.	

## QPA5368 Temperature Sensing Feature

The QPA5368 provides an internal NTC resistor for temperature sensing. This resistor is located right next to the output transistor stage. Within the application circuit the NTC is part of a voltage divider. The output voltage of the voltage divider ( $V_t$ ) can be correlated to the module backside temperature.

### Module Backside Temperature versus $V_t$ (typical values)

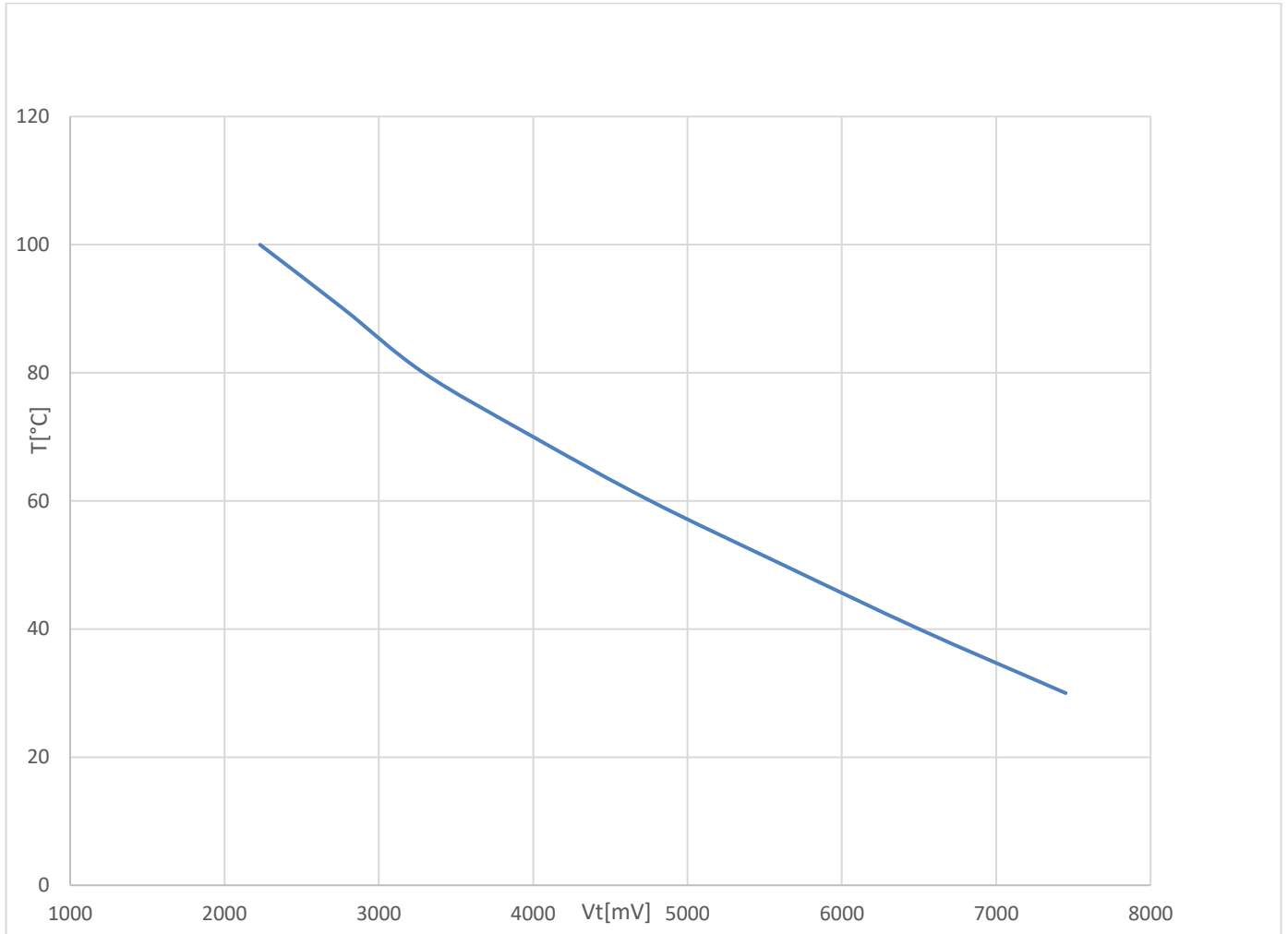

Package Outline Drawing (Dimensions in millimeters)

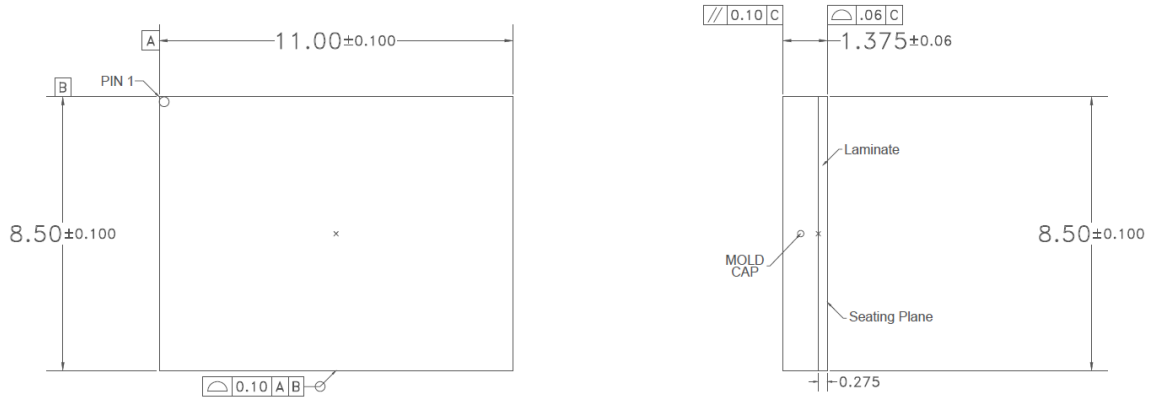

Notes:

1. Dimension and tolerance formats conform to ASME Y14.5M-1994.
2. The terminal #1 identifier and terminal numbering conform to JESD 95-1 SPP-012.
3. Co-planarity applies to the exposed ground/thermal pad as well as the contact pins.
4. Package body length/width does not include plastic flash protrusion across mold parting line.

PCB Metal Land Pattern

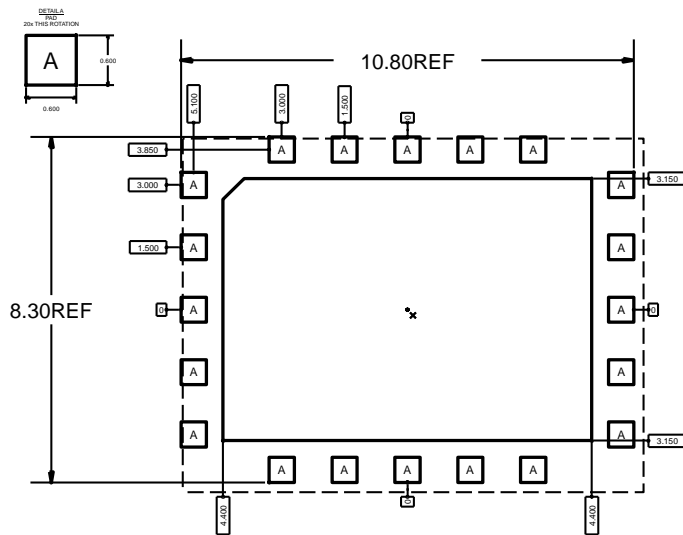

RECOMMENDED LAND PATTERN

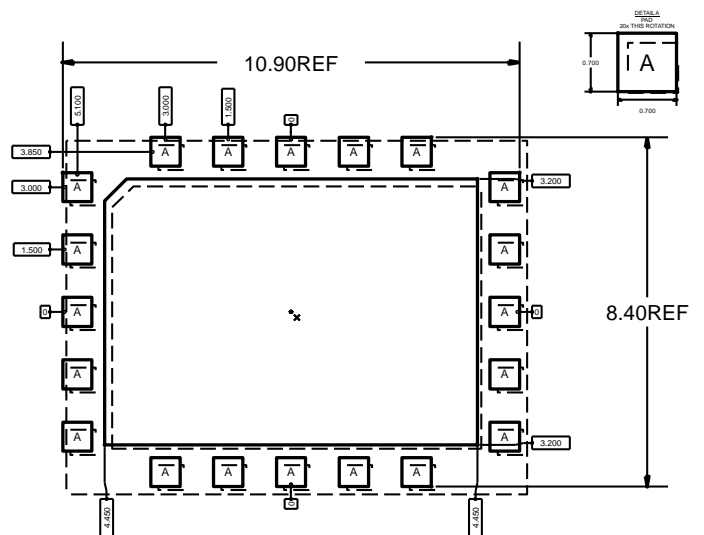

RECOMMENDED LAND PATTERN MASK

Notes:

1. All dimensions are in millimeters. Angles are in degrees.