

Product Overview

The QPC3024 is a 75Ω Silicon on Insulator (SOI) single-pole, double throw (SPDT) switch designed for use in CATV, satellite set top, and other high performance communications systems. It offers a high isolation symmetric topology with excellent linearity and power handling capability. No blocking caps are necessary on the RF ports. The design is non-reflective such that RF ports 1 and 2 are terminated in in the off-state. The V_{EN} pin allows for a terminated “all-off state”. Applying a negative voltage to the V_{NEG} pin will turn the negative voltage generator off and allow for external supply input.

Functional Block Diagram

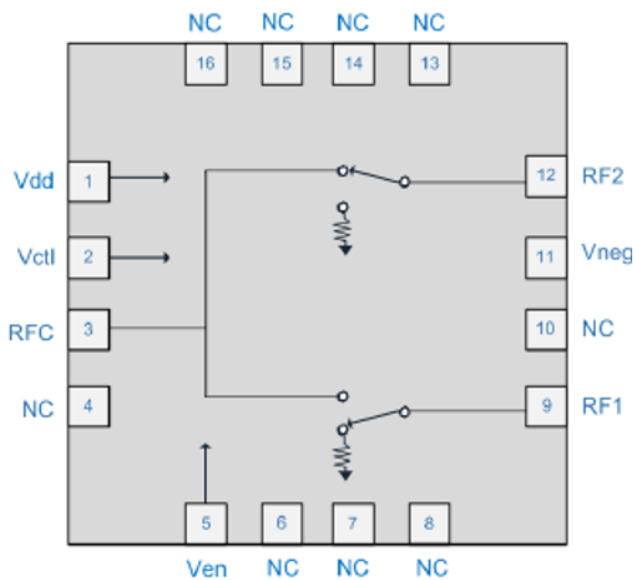

Top View

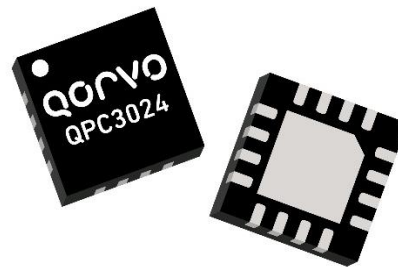

16 Pad 4 x 4 mm QFN Package

Key Features

- 5 MHz to 3000 MHz Operation
- Symmetric SPDT
- Non-Reflective (RF1, RF2)
- Terminated All-Off State
- No Blocking Caps Required Unless Voltage on RF Line
- High Isolation: >65 dB at 1.2 GHz
- High Input IP3: >60 dBm
- Option to Turn Off Negative Voltage Generator and Supply V_{NEG} Externally
- 2 kV ESD
- +1.8 V Logic Compatible

Applications

- MDU Amplifiers
- Point To Point
- Optical Nodes
- Set Top Box
- PCTV
- Multi-tuner DVR

Ordering Information

Part No.	Description
QPC3024SQ	Sample bag with 25 pieces
QPC3024SR	7" Reel with 100 pieces
QPC3024TR13	13" Reel with 2500 pieces
QPC3024PCK	5 – 3000 MHz PCBA with 5 pc. sample bag

Absolute Maximum Ratings

Parameter	Rating
Control Voltage (V_{CTL} , V_{EN})	+6.0 V
Supply Voltage (V_{DD})	+6.0 V
External Negative Supply (V_{NEG})	-6.0 V
Maximum CW Input Power at 25°C	+36 dBm
Maximum CW Input Power, Terminated Port	+28 dBm
Junction Temperature	+125°C
Storage Temperature Range	-40 to +150°C

Exceeding any one or a combination of the Absolute Maximum Rating conditions may cause permanent damage to the device. Extended application of Absolute Maximum Rating conditions to the device may reduce device reliability.

Recommended Operating Conditions

Parameter	Min	Typ	Max	Units
Supply Voltage, V_{DD}	+2.7	+3	+5.5	V
Supply Voltage, V_{NEG}	-5.5	-5	-3	V
Temperature Range	-40		+105	°C

Electrical specifications are measured at specified test conditions. Specifications are not guaranteed over all recommended operating conditions.

Electrical Specifications

Parameter	Conditions ⁽¹⁾	Min	Typ	Max	Units
Frequency Range		5		3000	MHz
Insertion Loss	5 MHz		0.38		dB
	50 MHz		0.42		
	1.2 GHz		0.82		
	2 GHz		0.83		
	3 GHz		1.4		
Isolation (RFC to RF1/RF2)	5 MHz		75		dB
	50 MHz		70		
	1.2 GHz		66		
	2 GHz		66		
	3 GHz		56		
Isolation (RF1 to RF2)	5 MHz		75		dB
	50 MHz		70		
	1.2 GHz		56		
	2 GHz		52		
	3 GHz		45		
Return Loss (RFC On-state)	5 MHz		33		dB
	50 MHz		32		
	1.2 GHz		15		
	2 GHz		17		
	3 GHz		13		
Return Loss (RF1/RF2 Off-state) Terminated Ports	5 MHz		40		dB
	50 MHz		39		
	1.2 GHz		19		
	2 GHz		18		
	3 GHz		25		

Notes:

1. Test Conditions Unless Otherwise Specified: $T_A = +25^\circ\text{C}$, $V_{CTL} = 0/+5\text{ V}$, $V_{DD} = +5\text{ V}$, 75 Ω system.

Electrical Specifications (cont'd.)

Parameter	Conditions ⁽¹⁾	Min	Typ	Max	Units
Input IP3 ⁽²⁾	1 GHz +12 dBm input power per tone, 1 MHz tone spacing		61		dBm
Input 1dB Compression Point ⁽²⁾	1 GHz		36		
Input 0.1dB Compression Point ⁽²⁾	1 GHz		36		
CSO	130 Channel, Flat Tilt, +42 dBmV/ch		>100		dBc
CTB	130 Channel, Flat Tilt, +42 dBmV/ch		>90		
Turn On Time	90% VDD to steady state harmonics		7.4		μs
Settling Time	50% control to steady state harmonics		3.8		
Switching Speed	50% control to 10/90% RF		1.5		
NVG Spurs	Internal NVG on (F<10MHz)		-113		dBm
Harmonics-2nd	5 MHz		-77		dBc
	17 MHz		-82		
	170 MHz		-95		
	800 MHz		-106		
Harmonics-3rd	5 MHz		-93		dBc
	17 MHz		-115		
	170 MHz		-119		
	800 MHz		-121		

Notes:

1. Test Conditions Unless Otherwise Specified: T_A = +25 °C, V_{CTL} = 0/+5 V, V_{DD} = +5 V, V_{NEG} = -5 V, 75 Ω system. Drive RFC, RFx output.
2. Tested at 50Ω.

Electrical Specifications - Power Supply

Parameter	Conditions ⁽¹⁾	Min	Typ	Max	Units
Supply Current (I _{DD})	V _{DD} = +5.0V		130	200	μA
Control Current (I _{CTL} , I _{EN})	V _{CTL} = +5.0V		0.5	5	μA
Low Control Voltage (V _{CTL} , V _{EN})	+1.8V Logic compatible	0		0.63	V
High Control Voltage (V _{CTL} , V _{EN})		1.1		VDD	V

Maximum Operating Power

Input	State	VEN	Power at 85C (dBm)	Power at 105C (dBm)	Theta-J (°C/W)
RFC, RF1/2	On	Low	34 ⁽¹⁾	31 ⁽¹⁾	125
RFC	Both Off	High	30	27	N/A
RF1/2	Off	Low or High	27	24	77
RF1/2 (Simultaneous)	Both Off	High	29 ⁽²⁾	26 ⁽²⁾	50

Notes:

1. Assuming load VSWR <3:1, for high VSWR loads, this value reduces by 3dB.
2. Total power in both loads being driving simultaneously.

Power Supply Sequencing Requirements

No power supply sequencing is required if VCTL or VEN are less than 4.1V. When VCTL and VEN are greater than 4.1V, for best reliability, apply V_{DD} before the applying the control voltage.

If the internal Negative Voltage Generator (NVG) is disabled by applying a negative voltage on V_{NEG}, V_{DD} must be power cycled after changing V_{NEG} to 0V to enable it again.

Truth Table

Control Input		Signal Path State	
V _{CTL}	V _{EN}	RFC-RF1	RFC-RF2
0	0	On	Off
1	0	Off	On
0	1	Off	Off
1	1	Off	Off

5-3000 MHz Evaluation Board Schematic (QPC3024PCK)

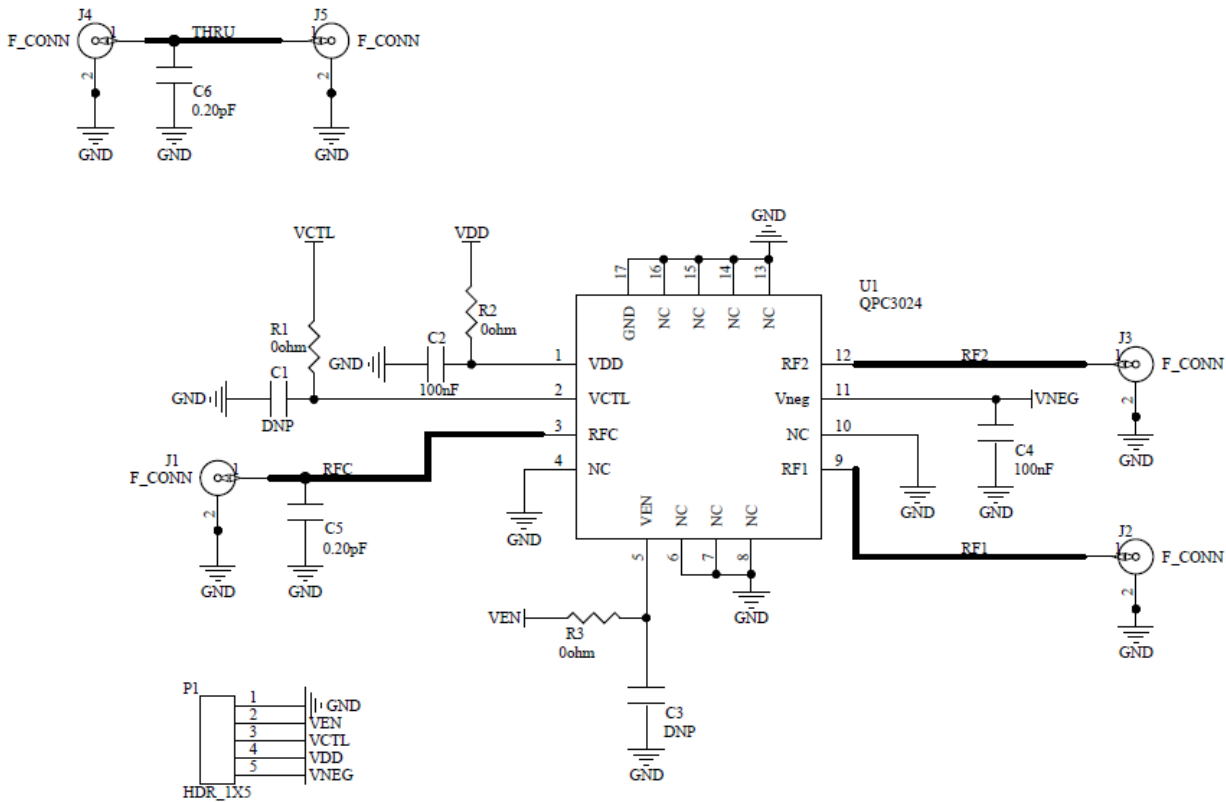

Ref. Designator	Description	Manufacturer	Part Number
PCB	Evaluation Board PCB	Viasystems	QPC3024-4000
U1	75ohm High Isolation Switch	Qorvo	QPC3024SB
J1, J2, J3, J4, J5	Conn, Type F, Edge Mount, 75 Ω, 0.065"	Genesis Technology	GT20-300204
R1, R2, R3	0 Ω RES, 0402	Panasonic	ERJ-2GE0R00X
P1	Conn, HDR, ST, 5-Pin, T/H	Molex	22-28-4053
C2, C4	100nF 10% X7R 16V CAP, 0402	Murata	GJM1555C1HR20RB12D
C5, C6	0.2pF +/- 0.03pF COG 50V CAP, 0402	Murata	GRM155R71C104KA88D
C1, C3	DNP	N/A	N/A

Evaluation Board Assembly Drawing



Performance Plots

Test conditions unless otherwise noted: $V_{DD} = +5V$, $V_{NEG} = -5V$, Temp = $+25^{\circ}C$, $Z_o = 75\Omega$

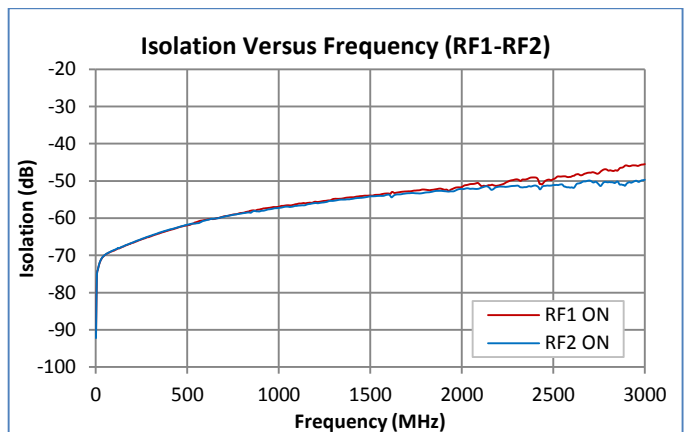
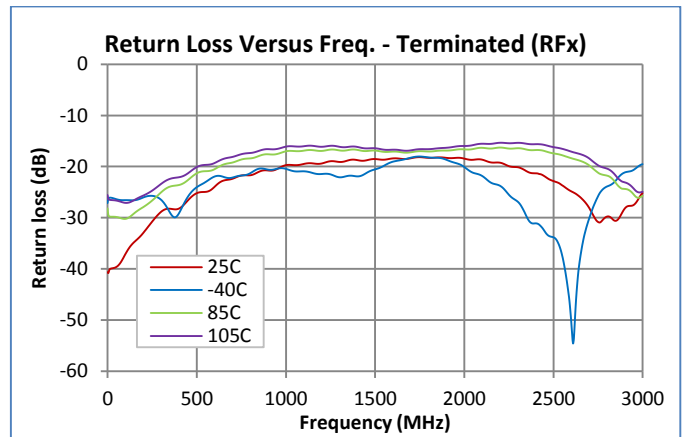
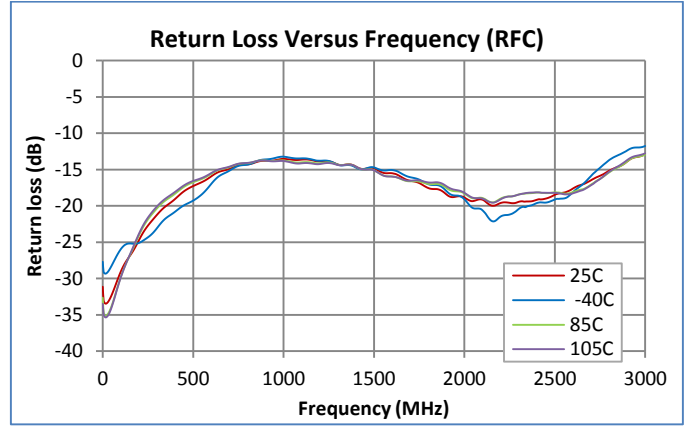

Performance Plots (cont'd.)

Test conditions unless otherwise noted: $V_{DD} = +5V$, $V_{NEG} = -5V$ Temp = $+25^{\circ}C$, $Z_o = 75\Omega$

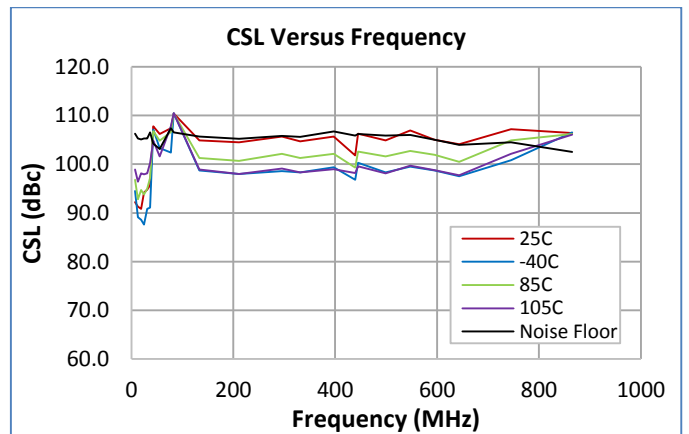
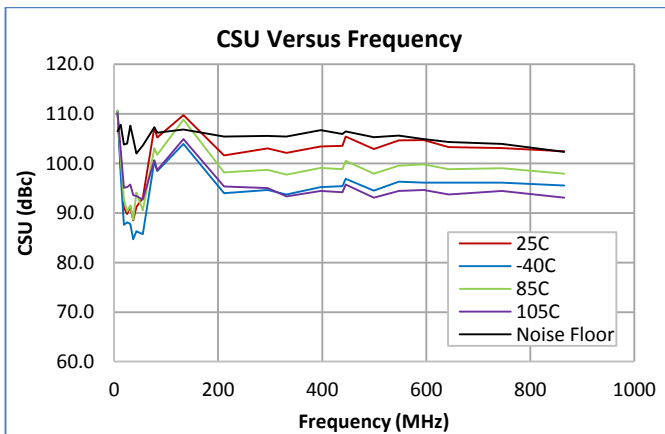
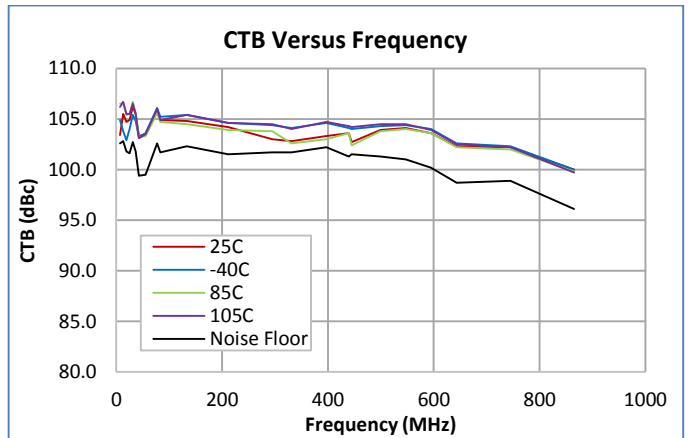
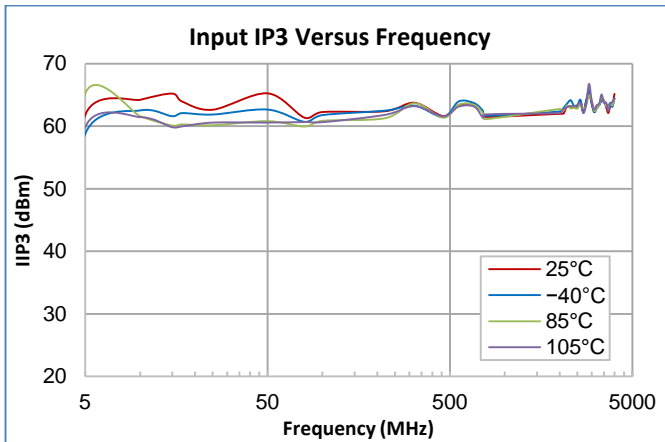
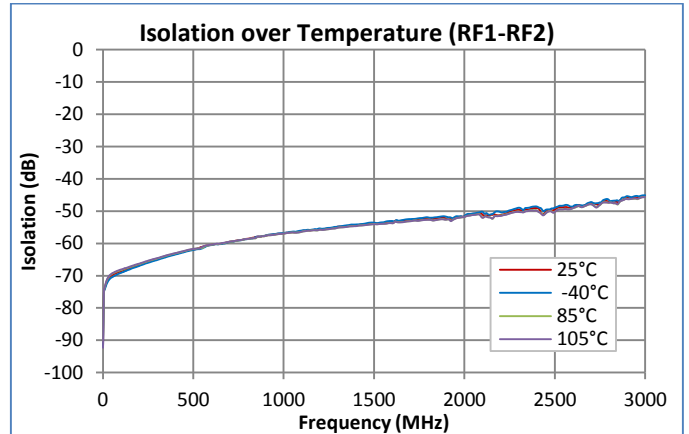

Test Conditions:

1. IIP3: Two tone, 50Ω, +12dBm per Tone.
2. CSO/CTB: 130 Channels, 42dBmV per Channel, Flat Tilt.

Performance Plots (cont'd.)

Test conditions unless otherwise noted: $V_{DD} = +5V$, $V_{NEG} = -5V$, Temp = $+25^{\circ}C$, $Z_o = 75\Omega$



MER/CCN Test Conditions:

1. 190 QAM256 Channels, 57-1215MHz, ITU-T J.83, Annex B
2. CCN test procedure according to ANSI/SCTE 17. System BW 5.36MHz.

Pad Configuration and Description



Top View

Pad No.	Label	Description
1	VDD	Supply Voltage
2	VCTL	Logic Control Input
3	RFC	RF Common Port
4	NC	Grounding this pin is recommended for performance
5	VEN	Logic input for putting switch in "all-off state". Logic high for "all-off state".
6, 7, 8, 13, 14, 15, 16	NC	Grounding this pin is recommended to maximize isolation
9	RF1	RF Port 1
10	NC	Grounding this pin is recommended for performance
11	VNEG	Negative Voltage Generator (NVG) control pin. Supply GND (Low inductive path to ground) to enable internal NVG or supply -2.7 V to -5 V to disable internal NVG. Once disabled, internal NVG cannot be enabled without cycling V _{DD} .
12	RF2	RF Port 2
EPAD	GND	RF and DC Ground: Must be soldered to EVB ground plane.

Applications Schematic; 5-1200MHz

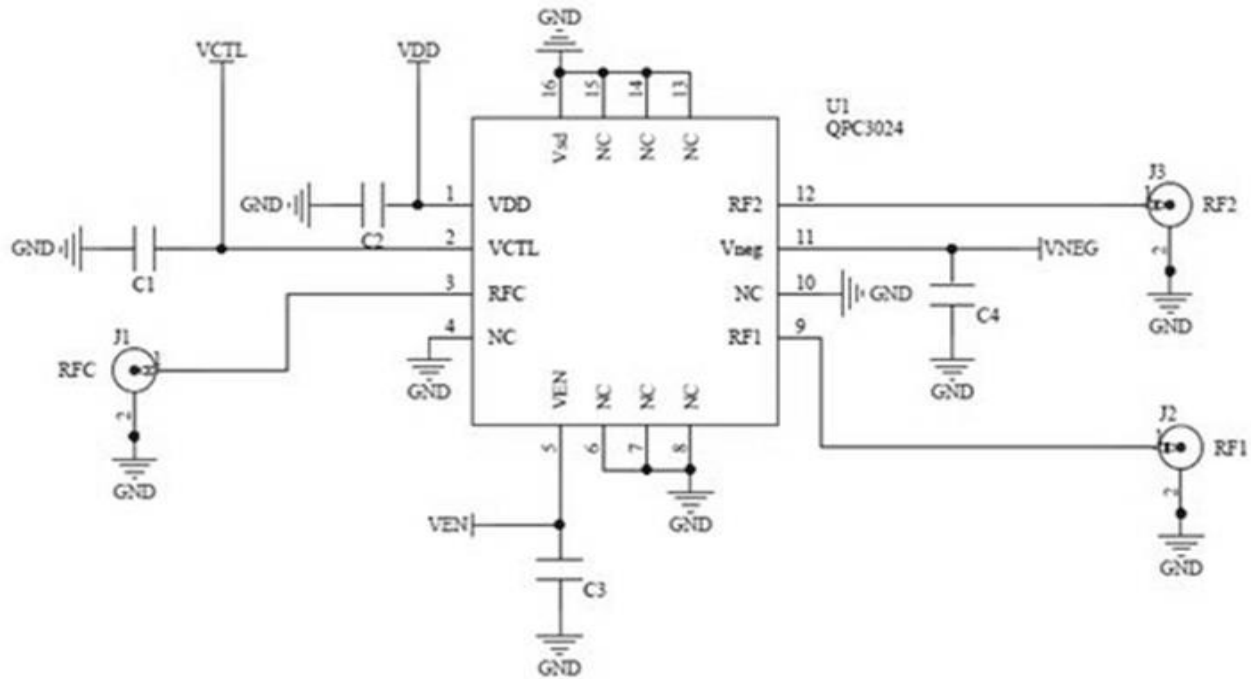

Package Dimensions



Notes:

1. All dimensions are in millimeters. Angles are in degrees.
2. The terminal #1 identifier and terminal numbering conform to JESD 95-1 SPP-012.
3. Contact plating: NiPdAu

Package Marking



Pin 1 Indicator

Trace Code to be assigned by SubCon
