

Product Overview

The QPC6064 is a Silicon on Insulator (SOI) Single-Pole 6-Throw (SP6T) switch designed for uses in cellular, 3G, LTE and other high-performance communication systems. It offers a high isolation, identical throw ports with excellent linearity and power handling capability. No DC blocking capacitors are necessary on the RF ports. The design is non-reflective as such the RF1, RF2, RF3, RF4, RF5 and RF6 ports are internally terminated with 50 Ω load(s) in the non-throw or OFF state. The QPC6064 is +1.8V control logic compatible. It incorporates the control to disable the internal Negative Voltage Generator (NVG) and the optional external negative voltage supplied to the same pin.

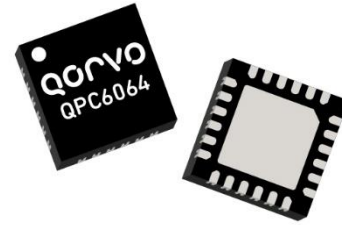

24-Pin, 4 x 4 mm QFN Package

Key Features

- 5 – 6000 MHz Operation
- Non-Reflective RF1, RF2, RF3, RF4, RF5 & RF6 Ports, Internally Terminated in OFF and All-OFF State
- No Blocking Capacitors Necessary Unless DC Voltage on RF line
- High Isolation: 50 dB at 2 GHz
- High Input IP3: +59 dBm
- +1.8 V Control Logic Compatible

Functional Block Diagram

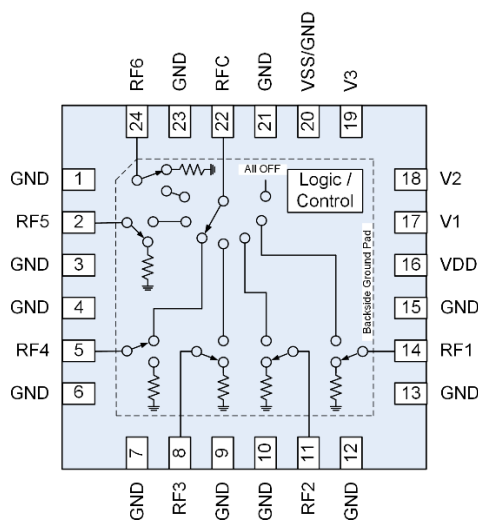

Top View

Applications

- Cellular, 3G, 4G, 5G Infrastructure
- WiBro, WiMAX, LTE
- High Performance Communication Systems
- Test Equipment

Ordering Information

Part No.	Description
QPC6064TR13	2,500 pieces on a 13" reel (standard)
QPC6064 PCK401	5 MHz – 6 GHz Evaluation Board with 5-piece samples

Absolute Maximum Ratings

Parameter	Rating	
Storage Temperature	-40 to +150 °C	
RF Input Power, non-internally terminated	+37.5 dBm	
RF Input Power, RFX internally terminated	+29 dBm	
Device Voltage	(VDD)	+6 V
	(VSS)	-6 V
Control Voltage (V1, V2, V3) Low / High	-0.2 V / +6 V	

Exceeding any one or a combination of the Absolute Maximum Rating conditions may cause permanent damage to the device. Extended application of Absolute Maximum Rating conditions to the device may reduce device reliability.

Recommended Operating Conditions

Parameter	Min	Typ	Max	Units
Device Voltage (VDD)	+2.7	+5.0	+5.5	V
Device Voltage (VSS), External Negative Voltage Supply	-5.5	-5.0	-2.7	V
Device Voltage (VSS), Internal Negative Voltage Generator		0		V
T _{CASE}	-40	+25	+105	°C
T _j for ≥10 ⁶ hours MTTF			+125	°C

Electrical specifications are measured at specified test conditions. Specifications are not guaranteed over all recommended operating conditions.

Electrical Specifications

Parameter	Conditions ⁽¹⁾	Min	Typ	Max	Units
Operational Frequency Range		5		6000	MHz
Insertion Loss	450 MHz		1.02		dB
	900 MHz		1.07		dB
	2100 MHz		1.18	1.30	dB
	2600 MHz		1.25		dB
	4000 MHz		1.41		dB
	6000 MHz		2.02		dB
Isolation (RFC – RF1/RF2/RF3/RF4/RF5/RF6)	450 MHz		72		dB
	900 MHz		66		dB
	2100 MHz, RF1/RF2/RF3/RF4/RF5	45	57		dB
	2100 MHz, RF6	35	40		dB
	2600 MHz		56		dB
	4000 MHz		52		dB
	6000 MHz		48		dB
Isolation (RF1/2/3/4/5/6 – RF1/2/3/4/5/6)	450 MHz		65		dB
	900 MHz		59		dB
	2100 MHz		51		dB
	2600 MHz		49		dB
	4000 MHz		44		dB
	6000 MHz		40		dB

Notes:

1. Test conditions unless otherwise noted: VDD = +5 V; V1, V2 and V3 = 0/+5V; T_A = +25 °C; Standard application circuit; 50 Ω system,

Electrical Specifications (continued)

Parameter	Conditions ⁽¹⁾	Min	Typ	Max	Units
Operational Frequency Range		5		6000	MHz
Return Loss (RF1/RF2/RF3/RF4/RF5/RF6 ON-State)	450 MHz		29		dB
	900 MHz		30		dB
	2100 MHz		27		dB
	2600 MHz		21		dB
	4000 MHz		20		dB
	6000 MHz		10		dB
Return Loss (RF1/RF2/RF3/RF4/RF5/RF6 OFF-State)	450 MHz		32		dB
	900 MHz		27		dB
	2100 MHz		21		dB
	2600 MHz		21		dB
	4000 MHz		20		dB
	6000 MHz		14		dB
Input IP2	1000 MHz		117		dBm
Input IP3	1.0 GHz, +17 dBm/tone, 1 MHz tone spacing	55	59		dBm
Input 1 dB Compression Power			36		dBm
NVG Spur	Internal NVG ON		-104		dBm
Setting Time	50% V1/V2/V3 to optimum functionality		1	4	μs
Start-up Time	90% VDD to full functionality		5	25	μs
Switching Time	50% control to 10/90% RF		150	240	ns
Supply Current (I _{VDD})	VDD +5.0V		90		μA
Control Current, (I _{V1} , I _{V2} , I _{V3})	V1, V2, V3 at +5.0V		1		μA
VSS Current (I _{VSS})	VSS -5.0V, Internal NVG disabled		100		μA
Low Control Voltage (V1, V2, V3)	+1.8 V Logic compatible	0		0.63	V
High Control Voltage (V1, V2, V3)		1.1		VDD	V

Notes:

 1. Test conditions unless otherwise noted: VDD = +5V; V1, V2 and V3 = 0/+5V; T_A = +25 °C; Standard application circuit; 50 Ω system

Truth Table

Control Input			Mode
V1	V2	V3	of Signal Path
0	0	0	All OFF, RFC Reflective; RF1, RF2, RF3, RF4, RF5 and RF6 Internally Terminated
1	0	0	RFC ⇌ RF1, Active ON; RF2, RF3, RF4, RF5 and RF6 Internally Terminated
0	1	0	RFC ⇌ RF2, Active ON; RF1, RF3, RF4, RF5 and RF6 Internally Terminated
1	1	0	RFC ⇌ RF3, Active ON; RF1, RF2, RF4, RF5 and RF6 Internally Terminated
0	0	1	RFC ⇌ RF4, Active ON; RF1, RF2, RF3, RF5 and RF6 Internally Terminated
1	0	1	RFC ⇌ RF5, Active ON; RF1, RF2, RF3, RF4, and RF6 Internally Terminated
0	1	1	All OFF, RFC Reflective; RF1, RF2, RF3, RF4, RF5 and RF6 Internally Terminated
1	1	1	RFC ⇌ RF6, Active ON; RF1, RF2, RF3, RF4, and RF5 Internally Terminated

Maximum Operating Power at High Temperature, ≥50 MHz CW, 50 Ω System

Input Port	State	Power at each port		Thermal Resistance, θ_{jc}
		Tc +85°C	Tc +105°C	
RFC, RF1, RF2, RF3, RF4, RF5 or RF6	ON, Active Throw ⁽¹⁾	35.5 dBm	32.3 dBm	53 °C/W
RF1, RF2, RF3, RF4, RF5 or RF6	OFF, 1 port ⁽³⁾	28.1 dBm	25.1 dBm	61 °C/W
RF1, RF2, RF3, RF4, RF5, RF6	OFF, 2 ports adjacent ⁽²⁾⁽³⁾	26.6 dBm	23.6 dBm	86 °C/W
RF1, RF2, RF3, RF4, RF5 and RF6	OFF, All 6 ports ⁽³⁾	26.2 dBm	23.1 dBm	96 °C/W

Notes:

1. For frequency <50 MHz, the maximum operating power at all temperatures should be at least 2 dB below P1dB refer to performance plot
2. On any two ports adjacent being driven simultaneously
3. Internally terminated OFF state

5 MHz to 6 GHz Evaluation Board – QPC6064PCK401

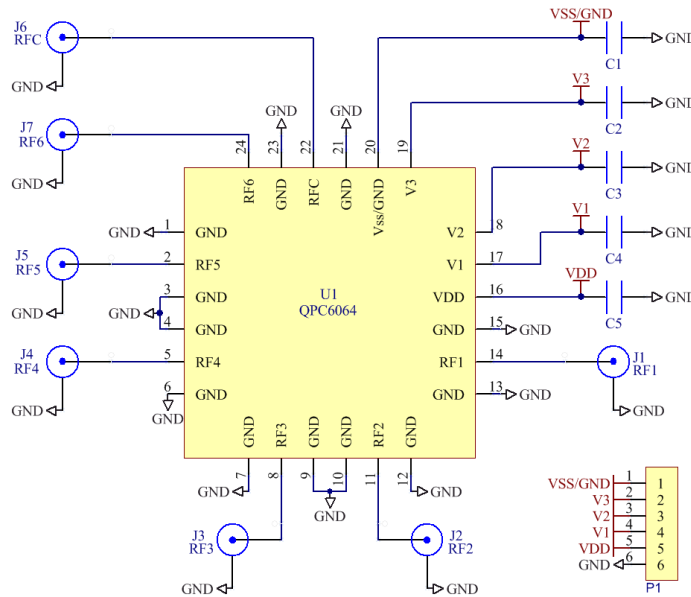
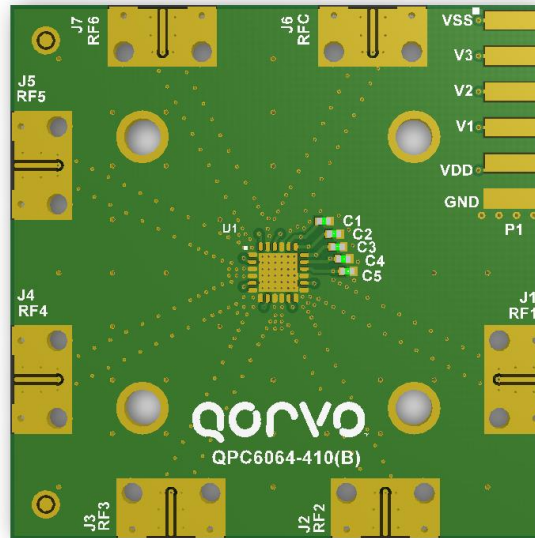

Bill of Material – QPC6064PCK401

Reference Des.	Value	Description	Manuf.	Part Number
-	-	PCB, QPC6064-410(B)	Qorvo	279707
U1	-	SOI, High Isolation SP6T RF switch	Qorvo	QPC6064
C1, C2, C3, C4, C5	100 pF	CAP, 100 pF, 5%, 50V, C0G, 0402	Taiyo Yuden	RM UMK105 CG101JV-F
J1, J2, J3, J4, J5, J6, J7	SMA	CONN, SMA, EL, FLT VIPER, MAT-21-1038	Amphenol	901-10425
P1	-	CONN, HDR, ST, PLRZD, 6-Pin, 0.100"	AMP	640454-6

Performance Plots – QPC6064PCK401

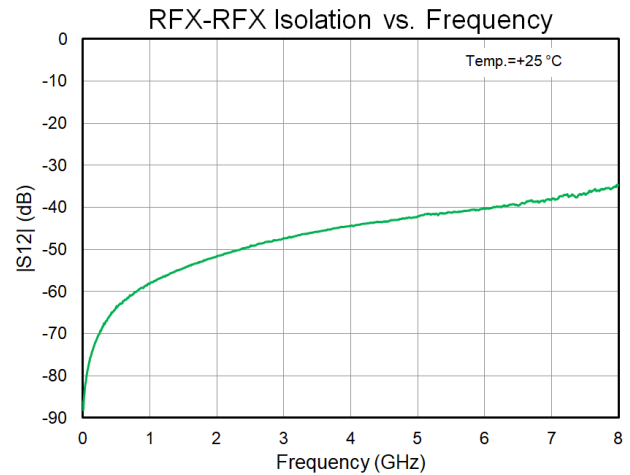
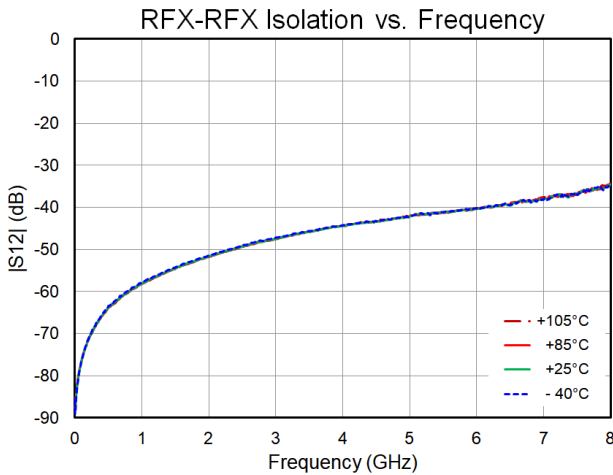
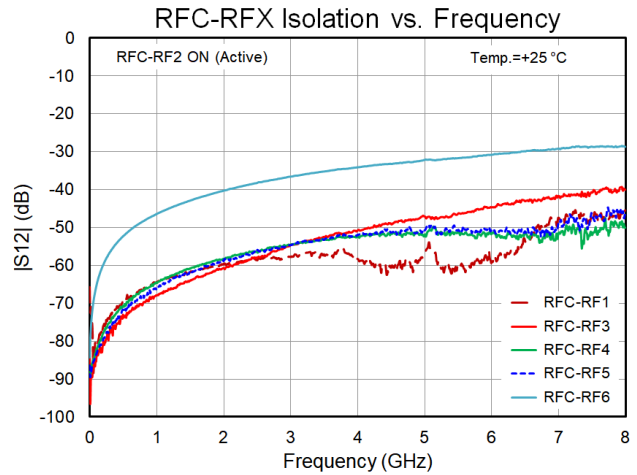
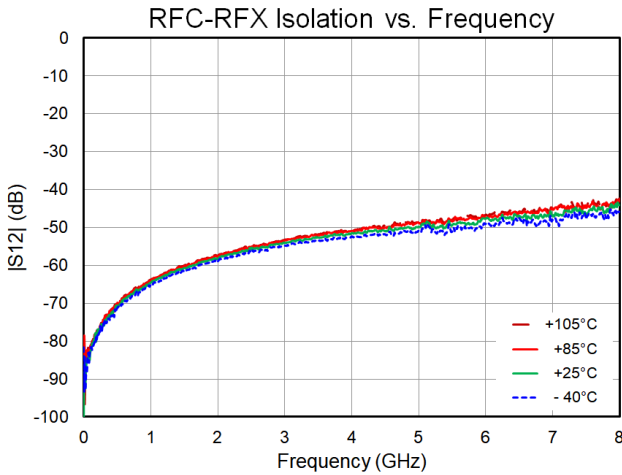
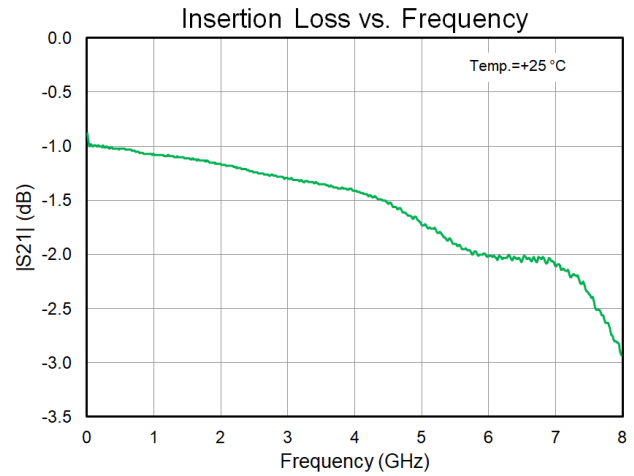
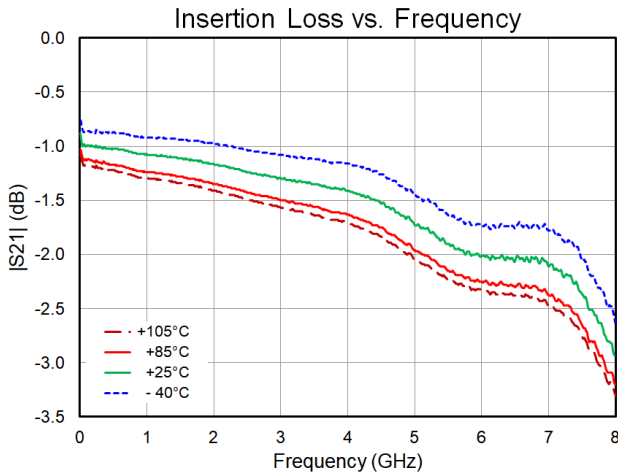

Performance Plots – QPC6064PCK410 (Continued)

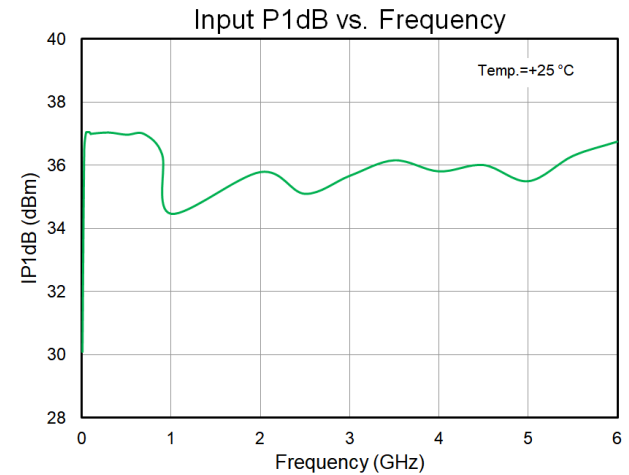
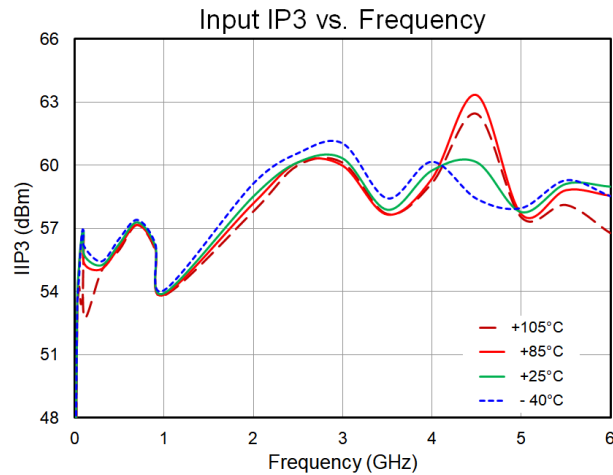
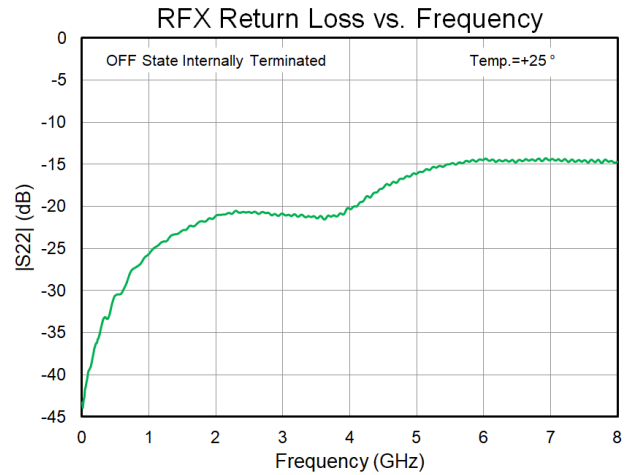
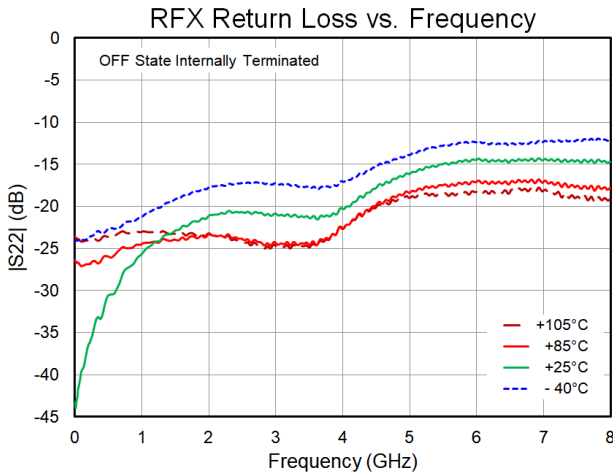
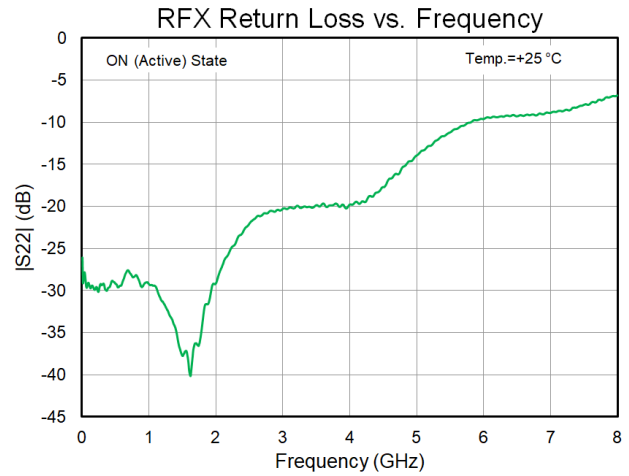
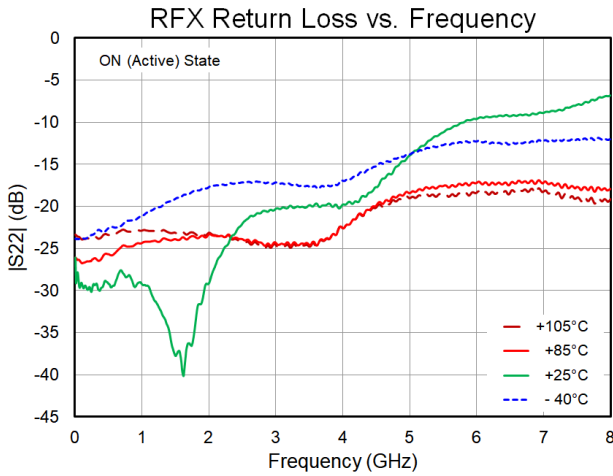

Pad Configuration and Description

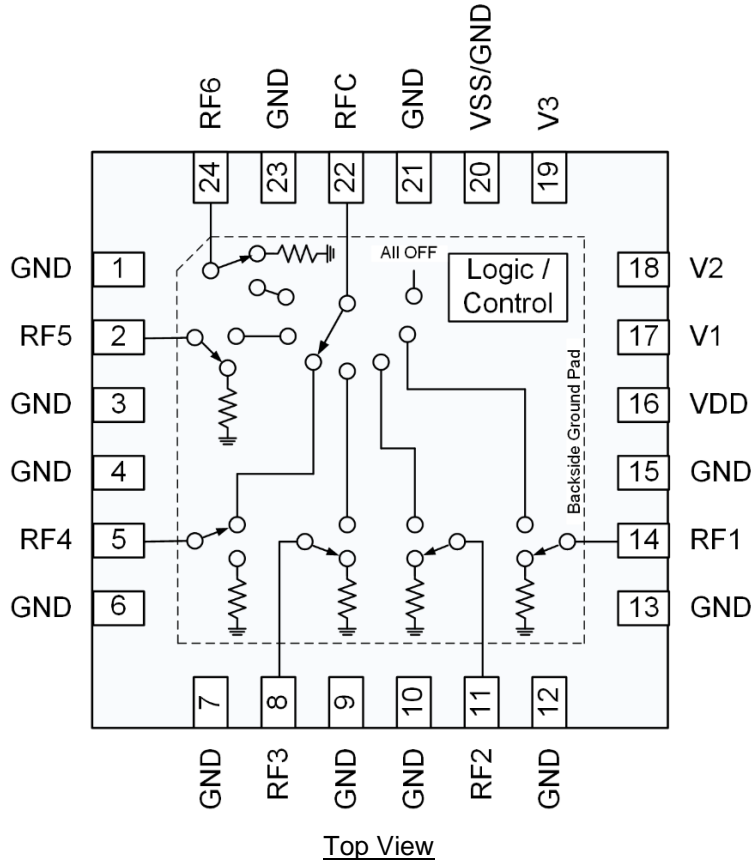

Pad No.	Label	Description
1, 3, 4, 6, 7, 9, 10, 12, 13, 15, 21, 23	GND	DC and RF ground, connect to low inductive path to PCB ground
2	RF5	RF Port 5
5	RF4	RF Port 4
8	RF3	RF Port 3
11	RF2	RF Port 2
14	RF1	RF Port 1
16	VDD	DC Supply Voltage Input
17	V1	Control Input 1
18	V2	Control Input 2
19	V3	Control Input 3
20	VSS/GND	Negative DC Supply Voltage and Internal Negative Voltage Generator (NVG) control input. Provide low inductive ground connection on this pin to enable internal NVG or directly connect -2.7V to -5V external voltage supply to disable the internal NVG. Re-enable internal NVG, VDD cycling required
22	RFC	RF Common Port
24	RF6	RF Port 6
Backside Paddle	GND	RF and DC ground. Must be soldered on PCB ground plane over a bed of via holes to minimize inductance and thermal resistance

Package Marking and Dimensions

Marking: Part Number – QPC
6064

Trace Code – Assigned by subcontractor

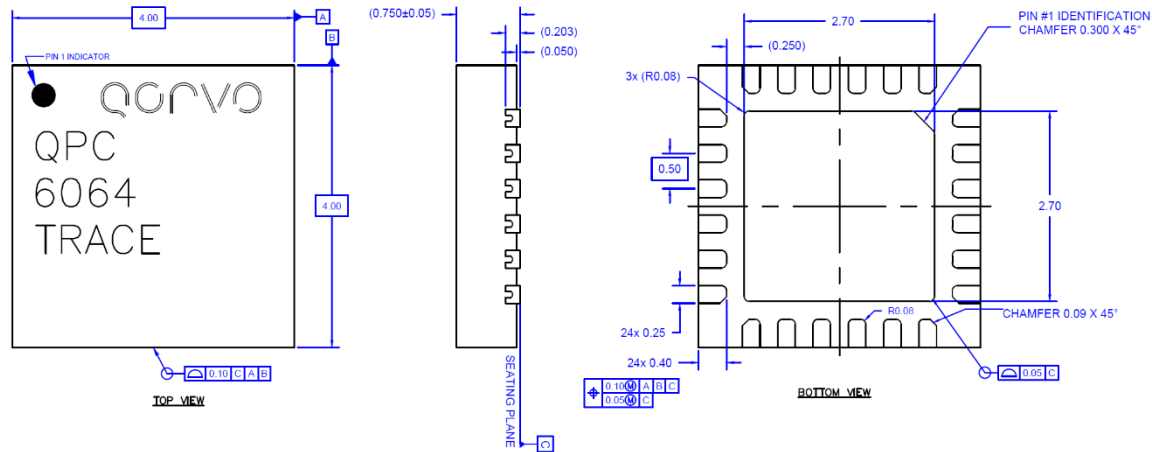

Notes:

1. All dimensions are in millimeters. Angles are in degrees.
2. The terminal #1 identifier and terminal numbering conform to JESD 95-1 SPP-012.
3. Contact plating: NiPdAu

PCB Mounting Pattern

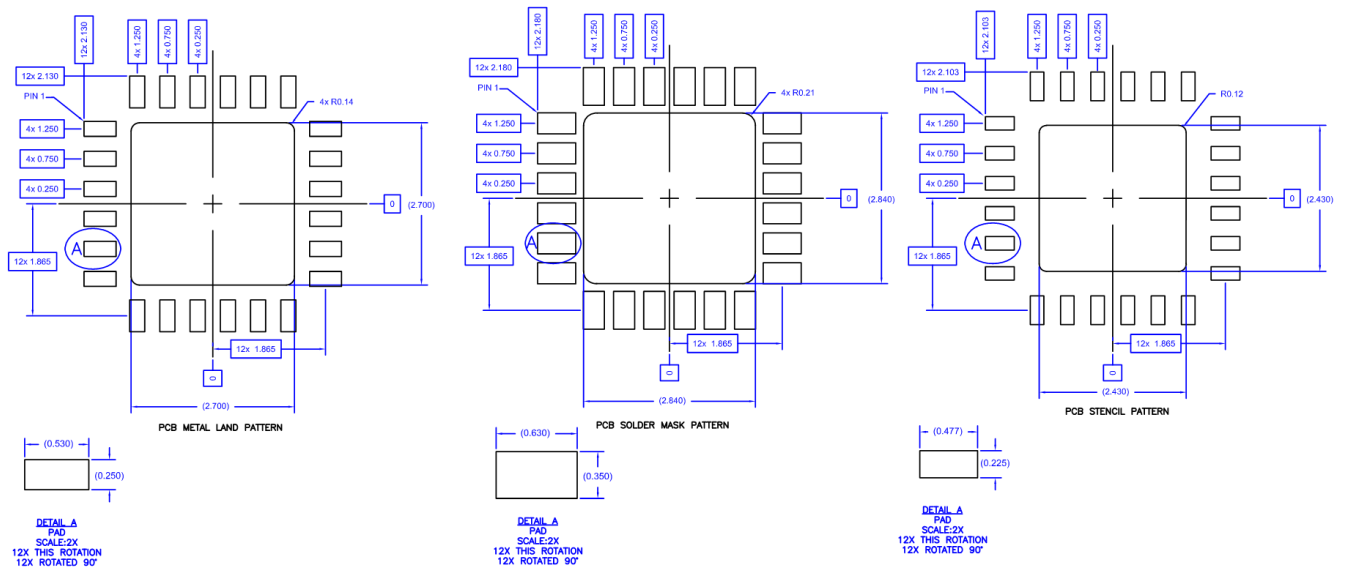

Notes:

1. All dimensions are in millimeters. Angles are in degrees.
2. Use 1 oz. copper minimum for top and bottom layer metal.
3. Via holes are required under the backside paddle of this device for proper RF/DC grounding and thermal dissipation. We recommend a 0.35mm (#80/.0135") diameter bit for drilling via holes and a final plated thru diameter of 0.25 mm (0.01").
4. Ensure good package backside paddle solder attach for reliable operation and best electrical performance.

Tape and Reel Information – Carrier and Cover Tape Dimensions

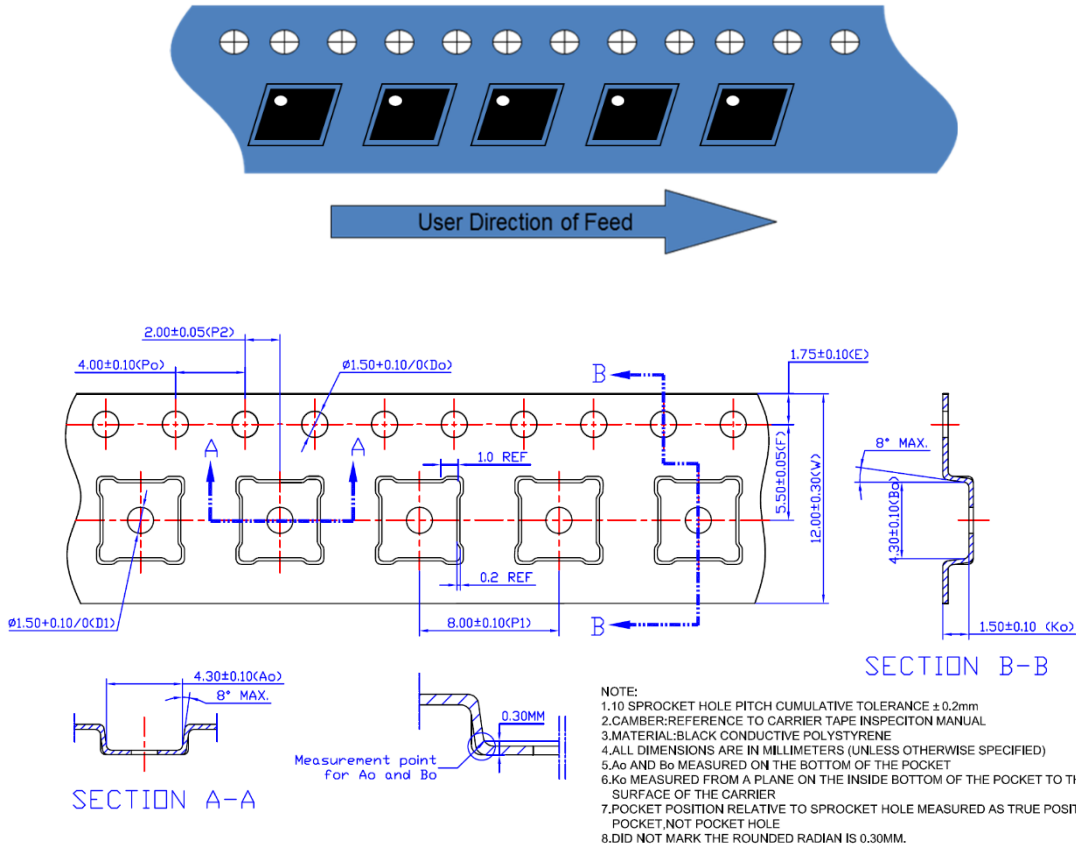

Feature	Measure	Symbol	Size (in)	Size (mm)
Cavity	Length	A0	0.169	4.30
	Width	B0	0.169	4.30
	Depth	K0	0.059	1.50
	Pitch	P1	0.314	8.00
Centerline Distance	Cavity to Perforation - Length Direction	P2	0.079	2.00
	Cavity to Perforation - Width Direction	F	0.217	5.50
Cover Tape	Width	C	0.362	9.20
Carrier Tape	Width	W	0.472	12.0

Tape and Reel Information – Reel Dimensions

Standard T/R size = 2,500 pieces on a 13" reel.

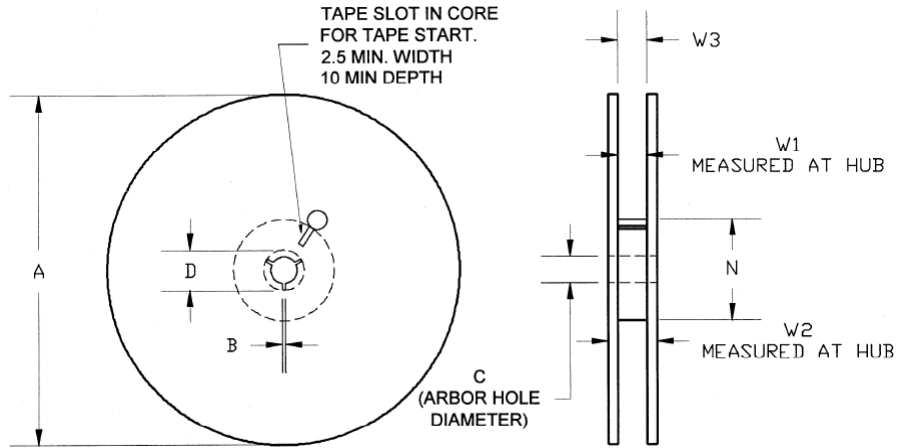

Feature	Measure	Symbol	Size (in)	Size (mm)
Flange	Diameter	A	12.992	330.0
	Thickness	W2	0.717	18.2
	Space Between Flange	W1	0.504	12.8
Hub	Outer Diameter	N	4.016	102.0
	Arbor Hole Diameter	C	0.512	13.0
	Key Slit Width	B	0.079	2.0
	Key Slit Diameter	D	0.787	20.0

Tape and Reel Information – Tape Length and Label Placement

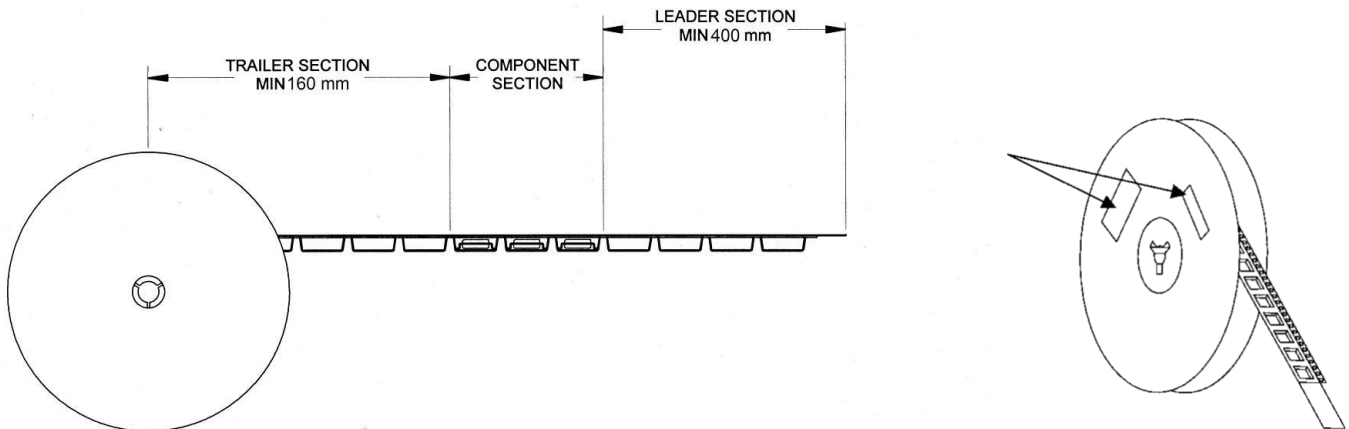

- Notes:
1. Empty part cavities at the trailing and leading ends are sealed with cover tape. See EIA 481-1-A.
 2. Labels are placed on the flange opposite the sprockets in the carrier tape.