

Product Overview

The QPC6762 is a 75Ω Silicon on Insulator (SOI) single-pole, six throw (SP6T) switch designed for use in CATV, satellite set top, and other high-performance communications systems. It offers a high isolation symmetric topology with excellent linearity and power handling capability. No blocking caps are necessary on the RF ports. QPC6762 is packaged in a convenient 2.0mm x 2.0mm QFN package

Functional Block Diagram

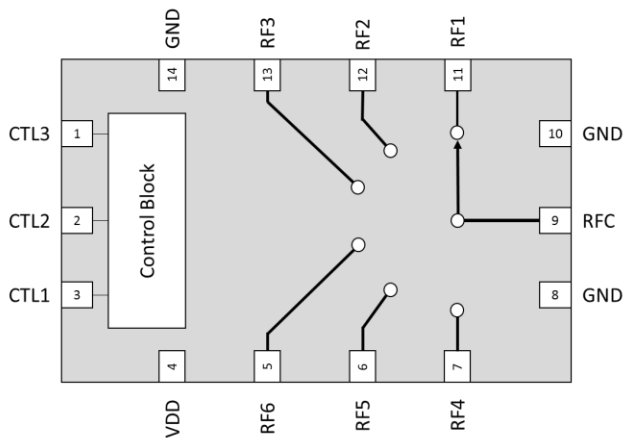

Top View

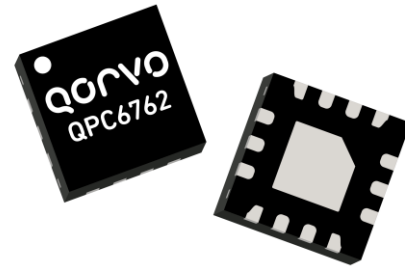

14 Pin 2.0 x 2.0mm QFN Package

Key Features

- 5MHz to 2000MHz Operation
- Low Insertion Loss: 0.4dB at 800MHz
- No Blocking Caps Required Unless Voltage on RF Line
- High Isolation: 34dB at 800MHz
- High Input IP3: 75dBm at 850MHz
- 2kV ESD
- +1.8V Logic Compatible
- 3V to 5V Operation

Applications

- MDU Amplifiers
- Point To Point
- Optical Nodes
- Set Top Box
- PCTV
- Multi-tuner DVR

Ordering Information

Part No.	Description
QPC6762SQ	Sample bag with 25 pieces
QPC6762SR	7" Reel with 100 pieces
QPC6762TR7	7" Reel with 2500 pieces
QPC6762PCK	5 – 2000MHz PCBA with 5 pc. sample bag

Absolute Maximum Ratings

Parameter	Rating
Control Voltage (V_{CTL})	3.0V
Supply Voltage (V_{DD})	6.0V
Maximum CW Input Power at 25°C	32dBm
Max Input Power During Active Switching	24dBm
Storage Temperature Range	-40 to +150°C

Exceeding any one or a combination of the Absolute Maximum Rating conditions may cause permanent damage to the device. Extended application of Absolute Maximum Rating conditions to the device may reduce device reliability.

Recommended Operating Conditions

Parameter	Min	Typ	Max	Units
Supply Voltage, V_{DD}	2.7	5	5.5	V
Temperature Range	-40		85	°C

Electrical specifications are measured at specified test conditions. Specifications are not guaranteed over all recommended operating conditions.

Electrical Specifications

Parameter	Conditions ⁽¹⁾	Min	Typ	Max	Units
Frequency Range		5		2000	MHz
Insertion Loss (RFC to RFx)	5MHz		0.28		dB
	50MHz		0.32		
	800MHz		0.40		
	1.2GHz		0.43		
	2GHz		0.52		
Isolation (RFC to RFx)	5MHz		50		dB
	50MHz		60		
	800MHz		34		
	1.2GHz		28		
	2GHz		23		
Isolation (RFx)	5MHz		55		dB
	50MHz		53		
	800MHz		24		
	1.2GHz		25		
	2GHz		17		
Return Loss (RFC)	5MHz		48		dB
	50MHz		36		
	800MHz		19		
	1.2GHz		23		
	2GHz		15		

Notes:

1. Test Conditions Unless Otherwise Specified: $T_A = +25^\circ\text{C}$, $V_{DD} = +5\text{V}$, $V_{CTL} = 0/+2.5\text{V}$, 75Ω system.

Electrical Specifications (cont'd.)

Parameter	Conditions ⁽¹⁾	Min	Typ	Max	Units
Input IP3	850MHz +12dBm input power per tone, 30MHz tone spacing		75		dBm
Input IP2	850MHz +12dBm input power per tone, 30MHz tone spacing		121		
Input 1dB Compression Point	850MHz		37		
Input 0.1dB Compression Point	850MHz		33		
MER	75dBmV composite at 885MHz		41.1		dB
CCN	75dBmV composite at 885MHz		55.8		
Switching Speed	10/90% RF		0.35		μs
Switching Speed	50% control to 10/90% RF		1.8		
Turn On Time	Time for VDD = 0V to part ON and RF = 90%		20		
NVG Spurs	5 - 30MHz		-117		dBm
Harmonics-2nd	5 MHz		-72		dBc
	50MHz		-76		
	850MHz		-130		
	1800MHz		-110		
Harmonics-3rd	5MHz		-93		dBc
	50MHz		-102		
	850MHz		-117		
	1800MHz		-106		

Notes:

1. Test Conditions Unless Otherwise Specified: T_A = +25°C, V_{DD} = +5V, V_{CTL} = 0/+2.5V, 75Ω system. Drive RFC, RFx output.

Electrical Specifications - Power Supply

Parameter	Conditions ⁽¹⁾	Min	Typ	Max	Units
Supply Current (I _{DD})	V _{DD} = +5.0V		65	120	μA
Control Current	CTL1, CTL2, CTL3			5	μA
Control Voltage High		1.3		2.7	V
Control Voltage Low		0		0.45	V

Power Supply Sequencing Requirements

Condition	Sequence
Power Up	Turn on VDD, then CTL1, CTL2, and CTL3, then (20μs or greater) apply RF signal
Power Down	Turn off RF signal, then CTL1, CTL2, and CTL3, then turn off VDD

Truth Table

Mode	Control Signals		
	CTL1	CTL2	CTL3
RFC to RF1	High	Low	Low
RFC to RF2	Low	High	Low
RFC to RF3	High	High	Low
RFC to RF4	Low	Low	High
RFC to RF5	High	Low	High
RFC to RF6	Low	High	High

5-2000 MHz Evaluation Board Schematic (QPC6762PCK)

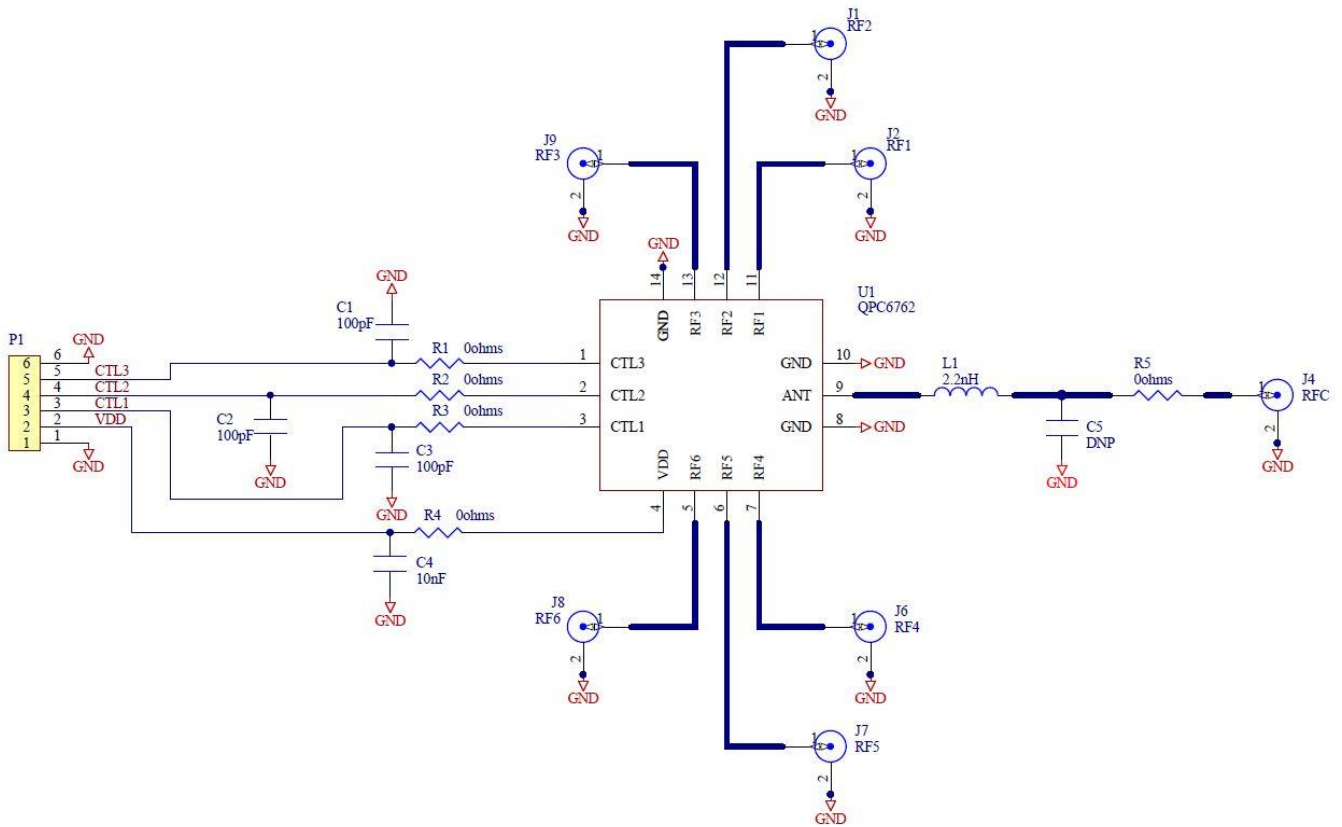

Ref. Designator	Description	Manufacturer	Part Number
PCB	Evaluation Board PCB	Viasystems	QPC6762-4000
U1	75ohm SP6T Switch	Qorvo	QPC6762SB
J1, J2, J4, J6, J7, J8, J9	F Connector, Edge Mount, 75 Ω, 0.065"	Genesis Technology	GT20-300204
R1, R2, R3, R4	0 Ω RES, 0402	Kamaya, Inc	RMC1/16SJPTH
R5	0 Ω RES, 50mohm max, 0402	KOA Speer Electronics	RK73Z1ETTP
P1	CONN, HDR, ST, PLRZD, 6-PIN, 0.100"	AMP	640454-6
C1, C2, C3	CAP, 100pF, 5%, 50V, COG, 0402	Murata	GRM1555C1H101JA01D
C4	CAP, 10nF, 10%, 25V, X7R, 0402	Murata	GRM155R71E103KA01D
L1	IND, 2.2nH, +/-0.1nH, M/L, Hi-Q, 0201	Taiyo Uden	LG HKQ0603W2N2B-T
C5	DNP	N/A	N/A

Evaluation Board Assembly (QPC6762PCK)

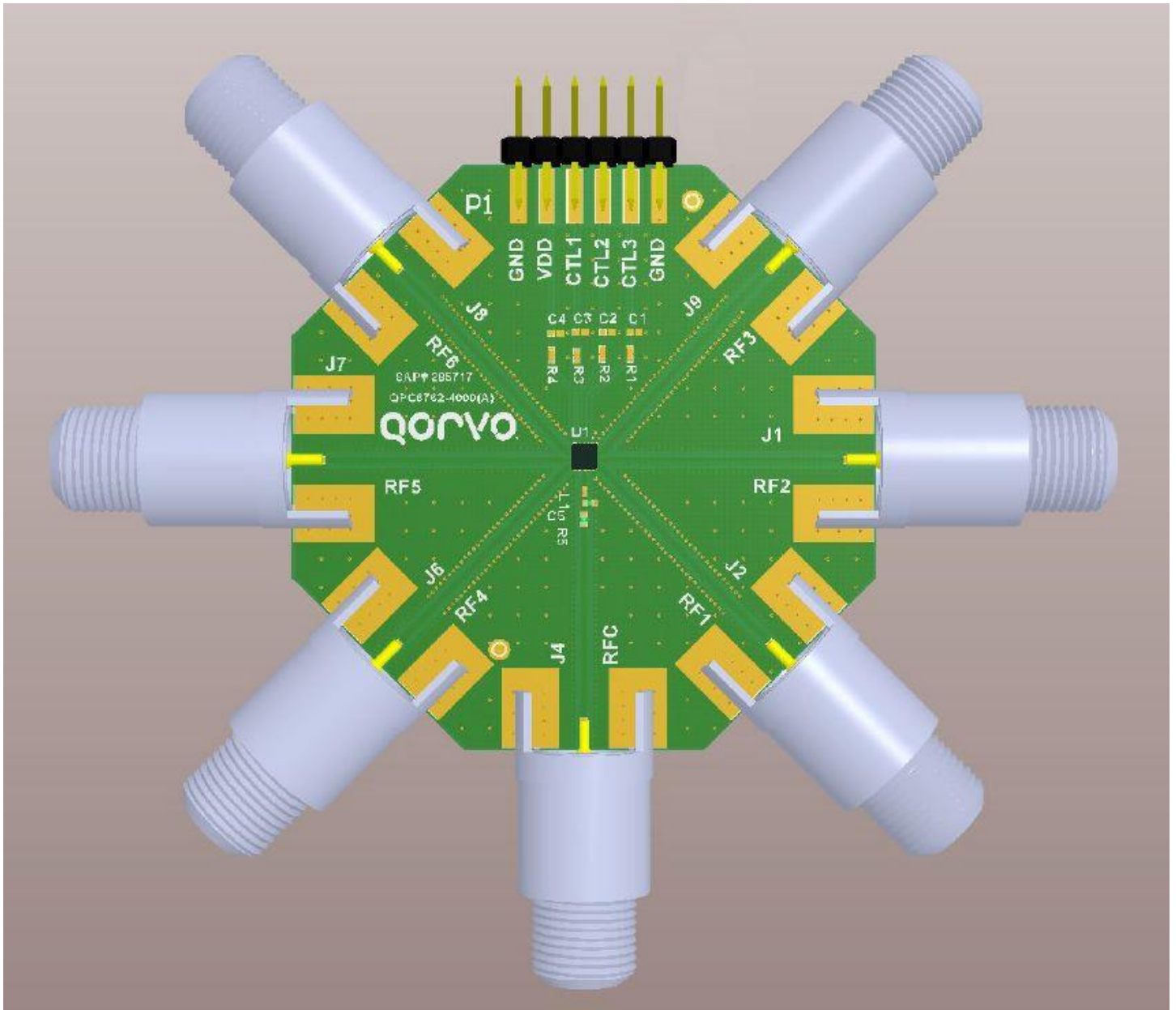

Performance Plots

Test conditions unless otherwise noted: $V_{DD} = +5V$, $V_{CTL} = 0 / 2.5V$, Temp = $+25^{\circ}C$, $Z_o = 75\Omega$

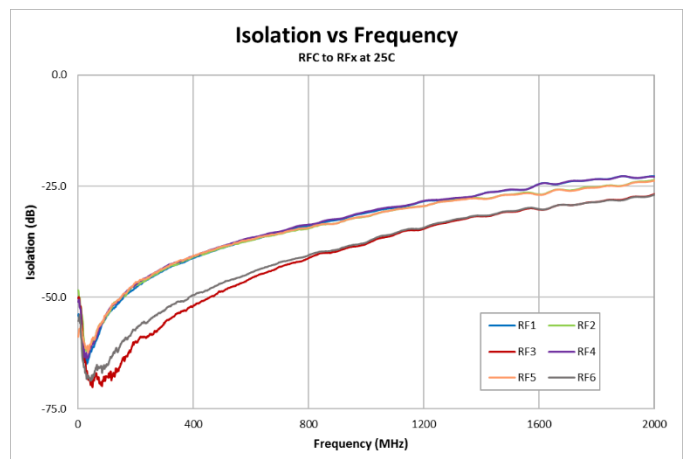
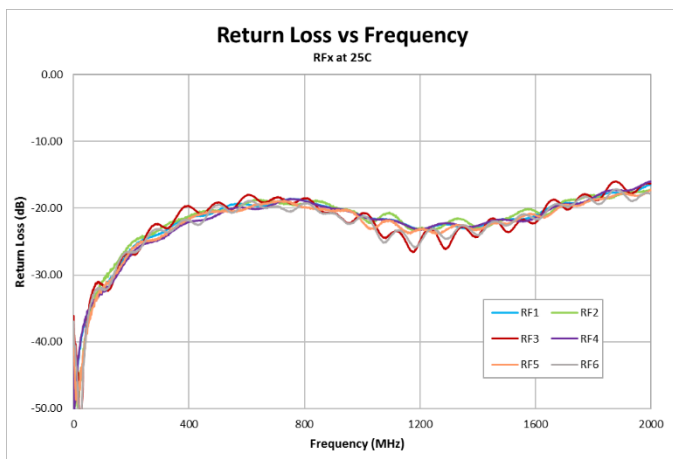
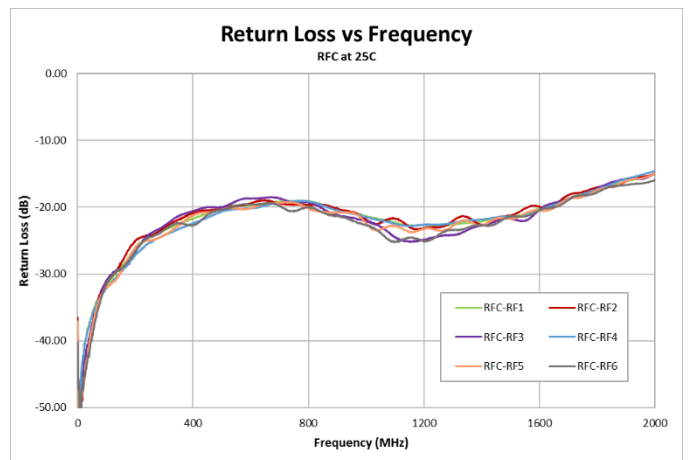
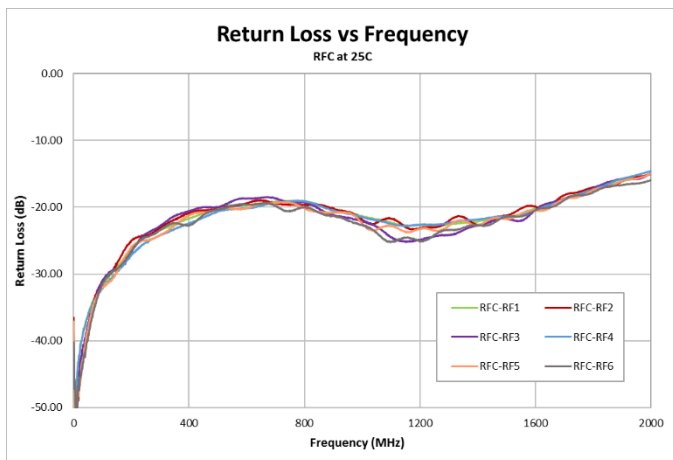
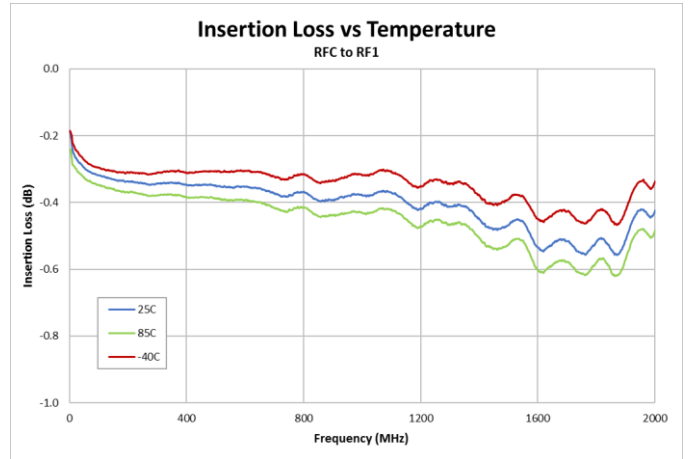
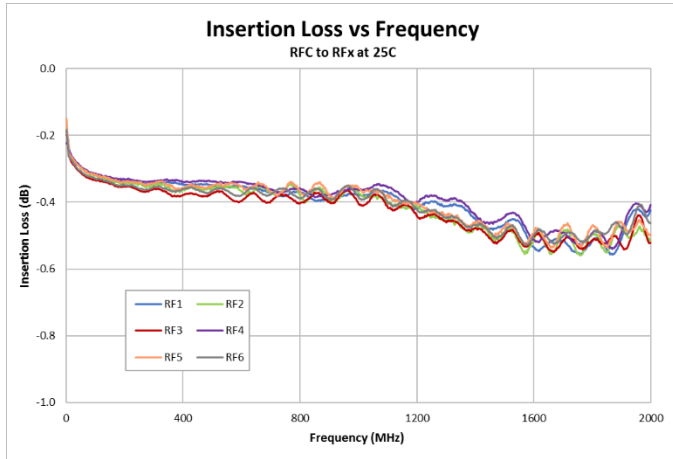

Notes:

1. Insertion Loss plots are loss compensated to remove effects of EVB.

Performance Plots (cont'd.)

Test conditions unless otherwise noted: $V_{DD} = +5V$, $V_{CTL} = 0 / 2.5V$, Temp = $+25^{\circ}C$, $Z_o = 75\Omega$

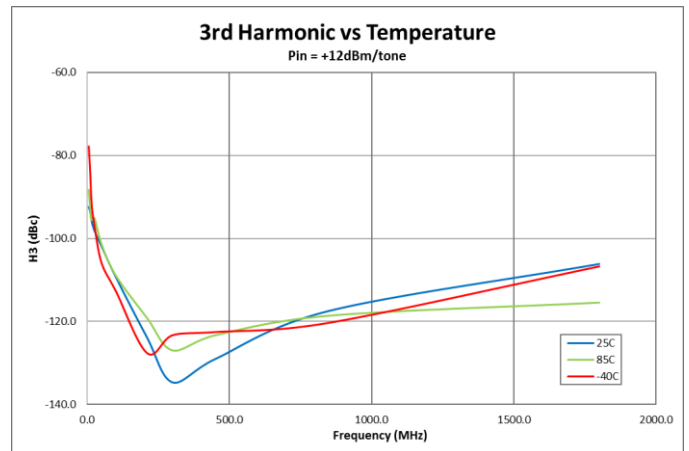
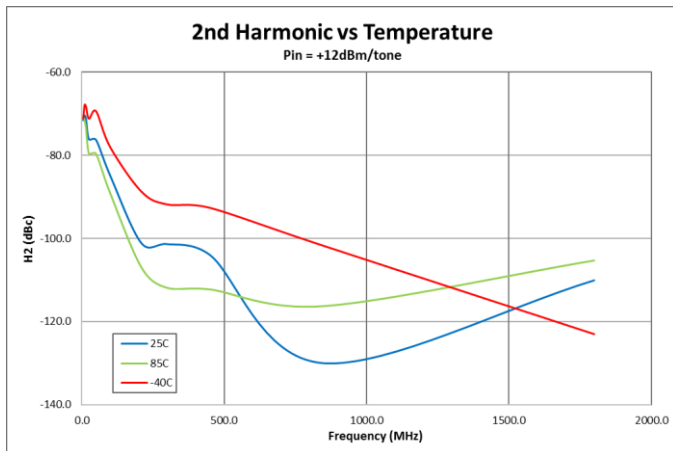
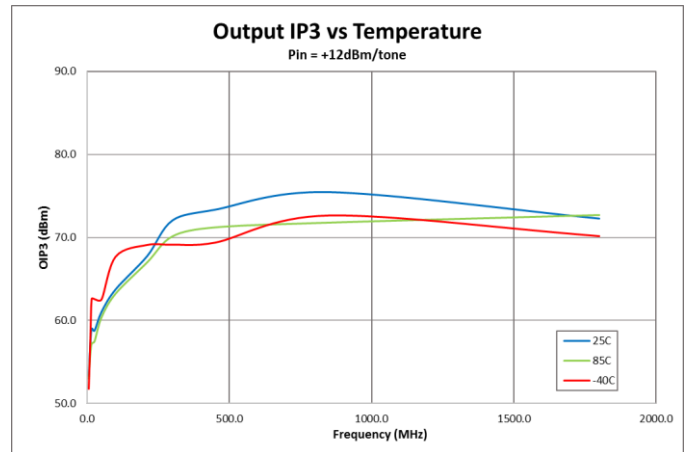
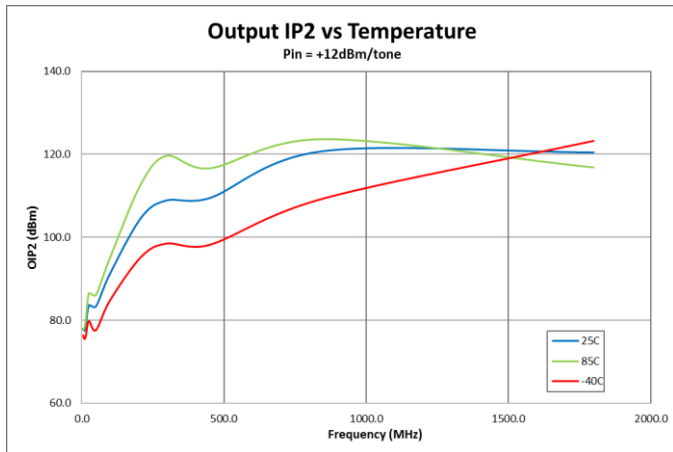
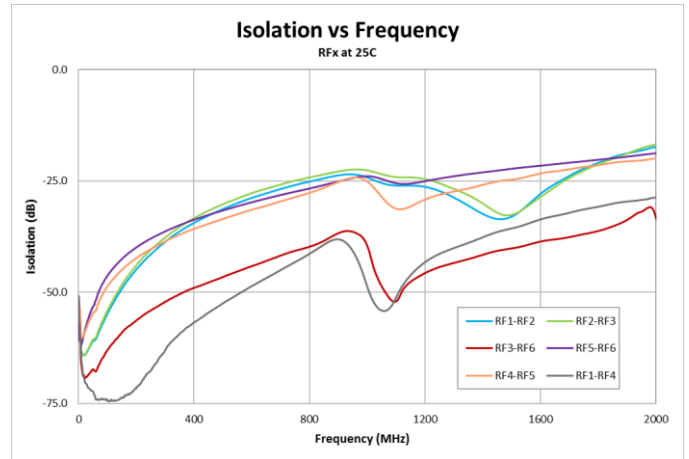
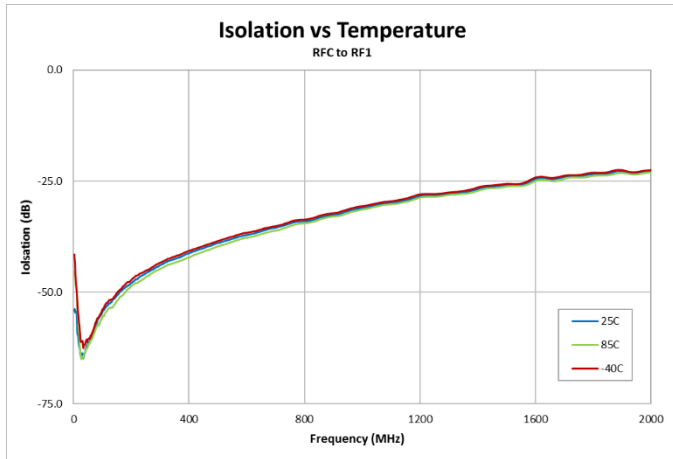

Performance Plots (cont'd.)

Test conditions unless otherwise noted: $V_{DD} = +5V$, $V_{CTL} = 0 / 2.5V$, Temp = $+25^{\circ}C$, $Z_0 = 75\Omega$

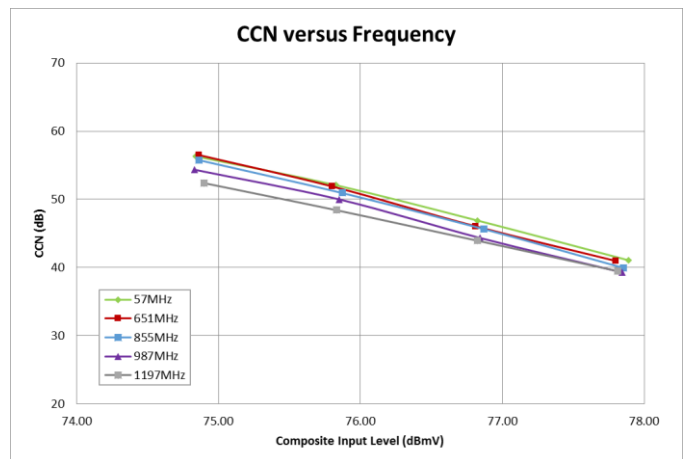
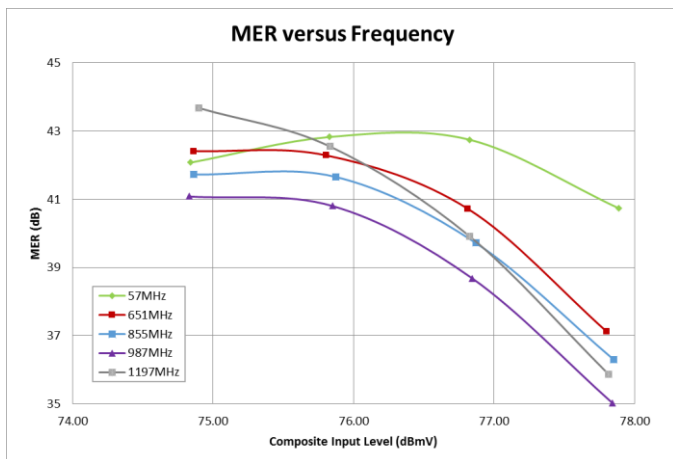
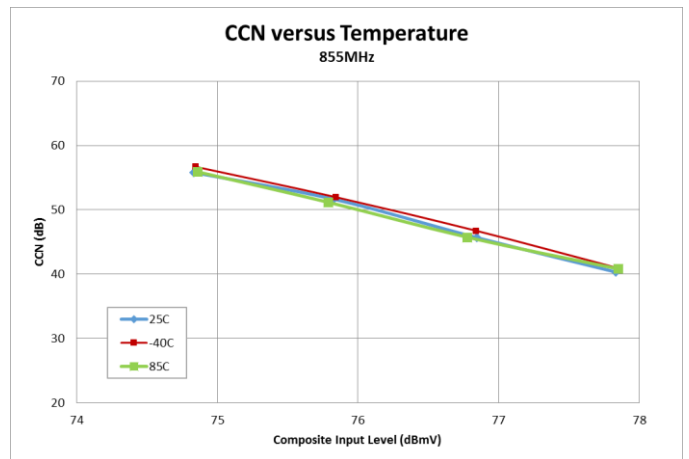
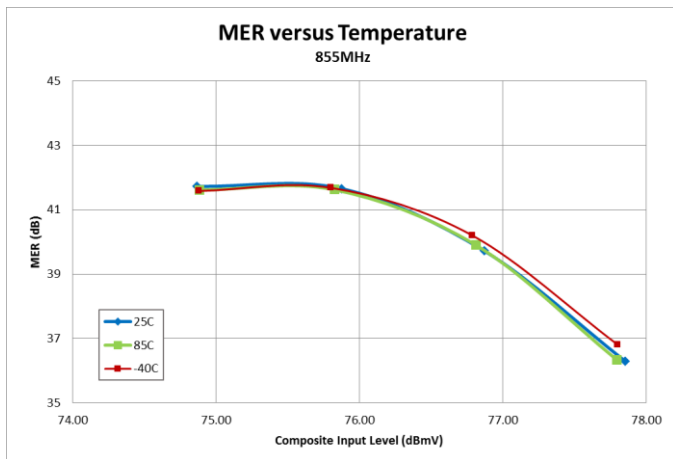
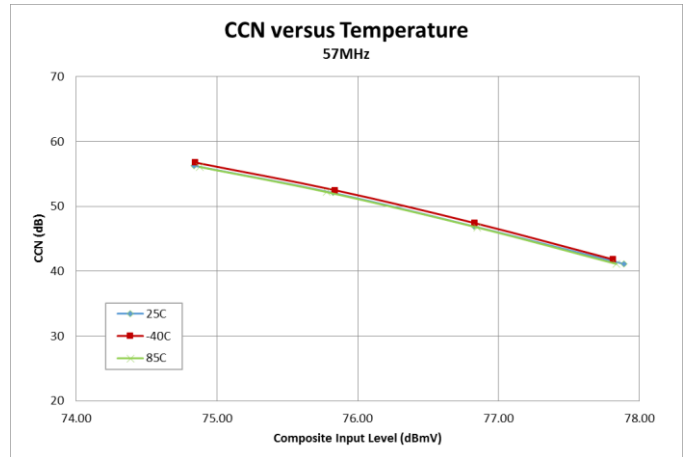
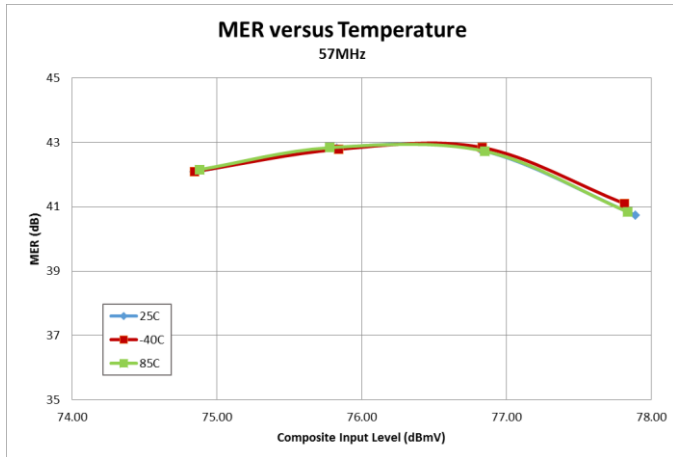

MER/CCN Test Conditions:

1. 190 QAM256 Channels, 57-1215MHz, ITU-T J.83, Annex B
2. CCN test procedure according to ANSI/SCTE 17. System BW 5.36MHz.

Pin Configuration and Description

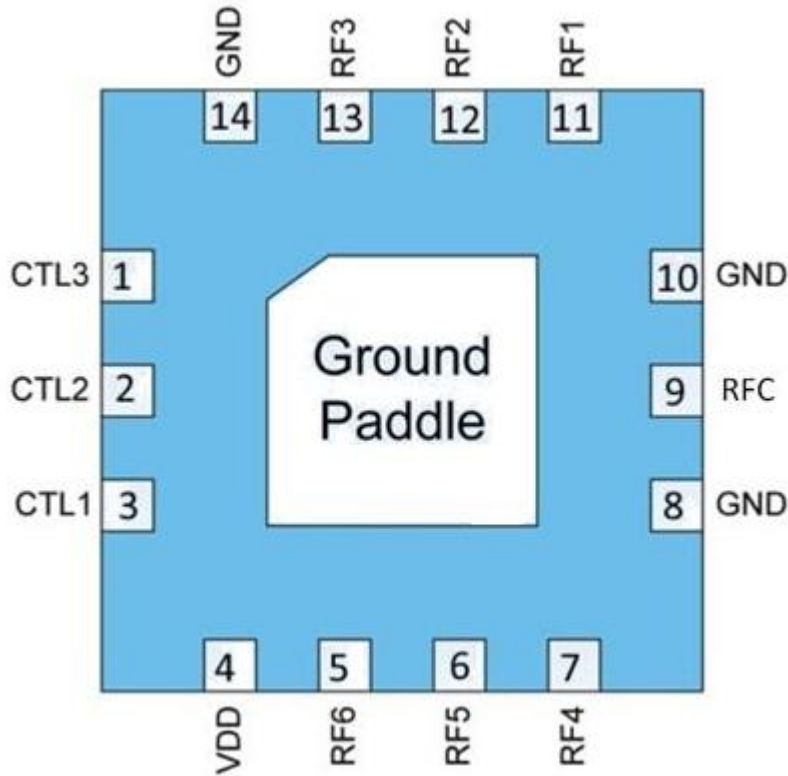

Top View

Pad No.	Label	Description
1	CTL3	Switch Logic Control 3
2	CTL2	Switch Logic Control 2
3	CTL1	Switch Logic Control 1
4	VDD	Supply Voltage
5	RF6	RF Output Port
6	RF5	RF Output Port
7	RF4	RF Output Port
8	GND	Ground
9	RFC	RF Input Port
10	GND	Ground
11	RF1	RF Output Port
12	RF2	RF Output Port
13	RF3	RF Output Port
14	GND	Ground

Applications Schematic; 5-2000MHz

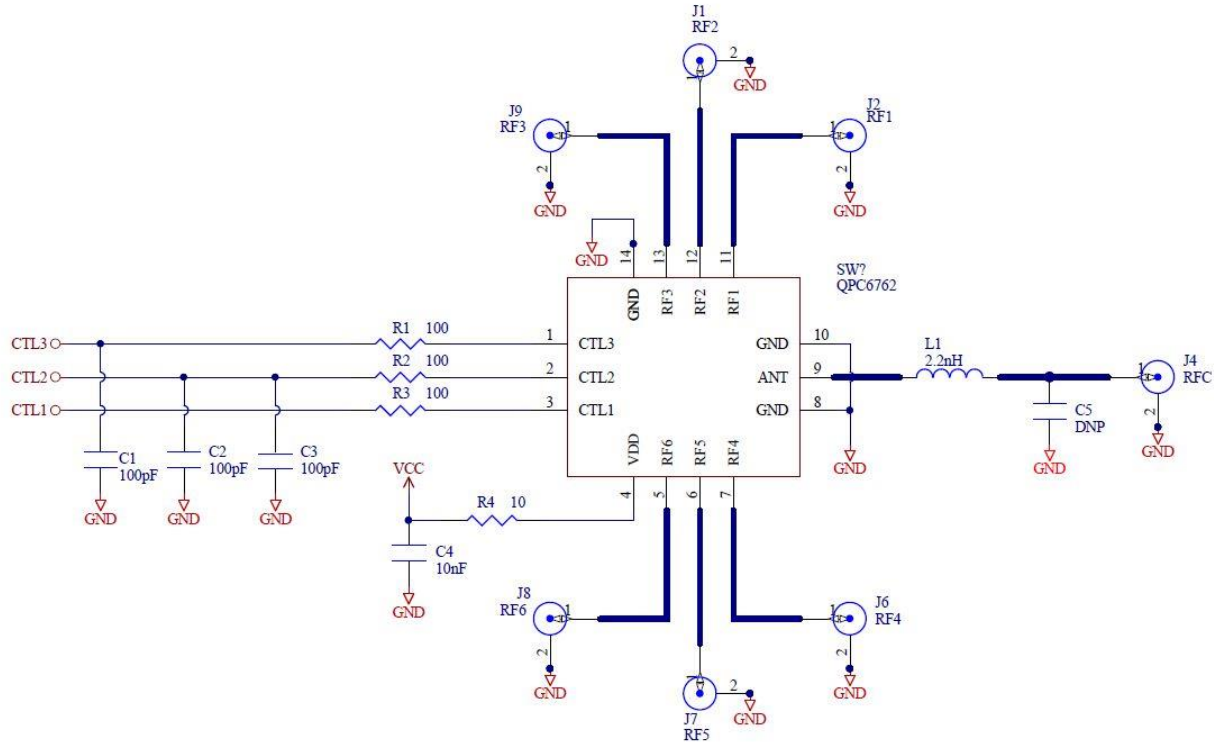

Notes:

1. R1-R4, C1-C4 optional for spurious or RFI suppression.
2. Isolation can be optimized by maximizing ground between RF Ports.
3. L1, C5 optional for improving high frequency return loss.

Package Dimensions

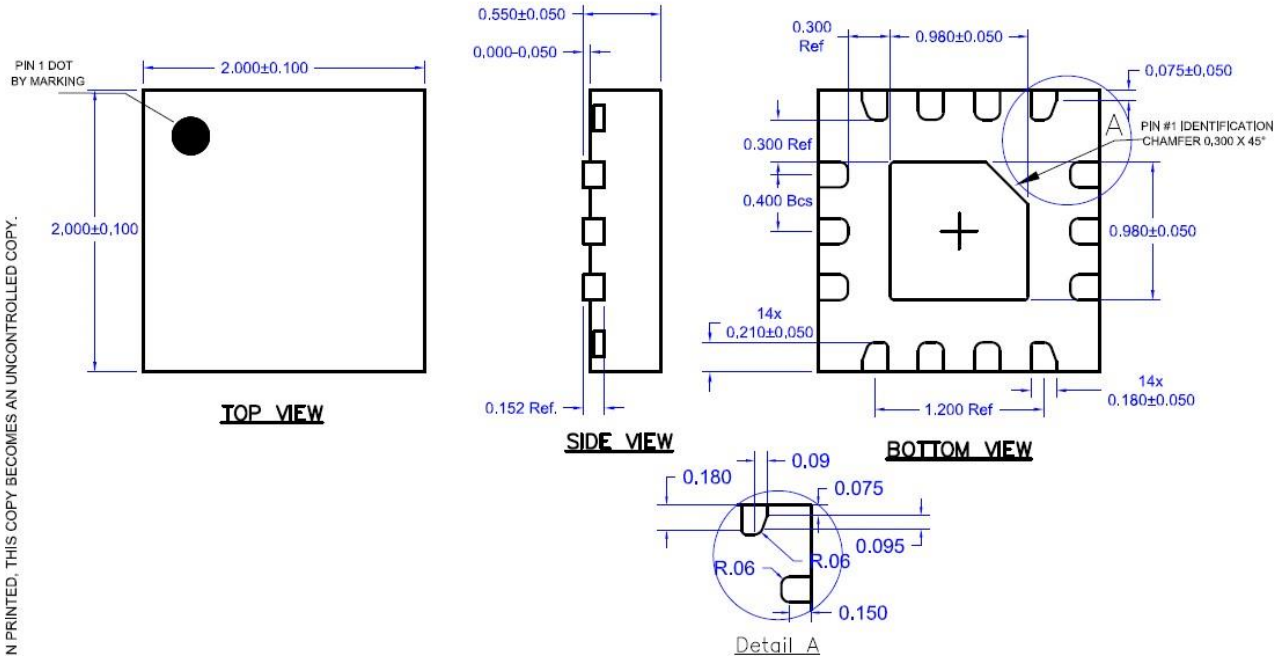

N PRINTED, THIS COPY BECOMES AN UNCONTROLLED COPY.

Notes:

1. All dimensions are in millimeters. Angles are in degrees.
2. The terminal #1 identifier and terminal numbering conform to JESD 95-1 SPP-012.
3. Contact plating: NiPdAu

Package Marking

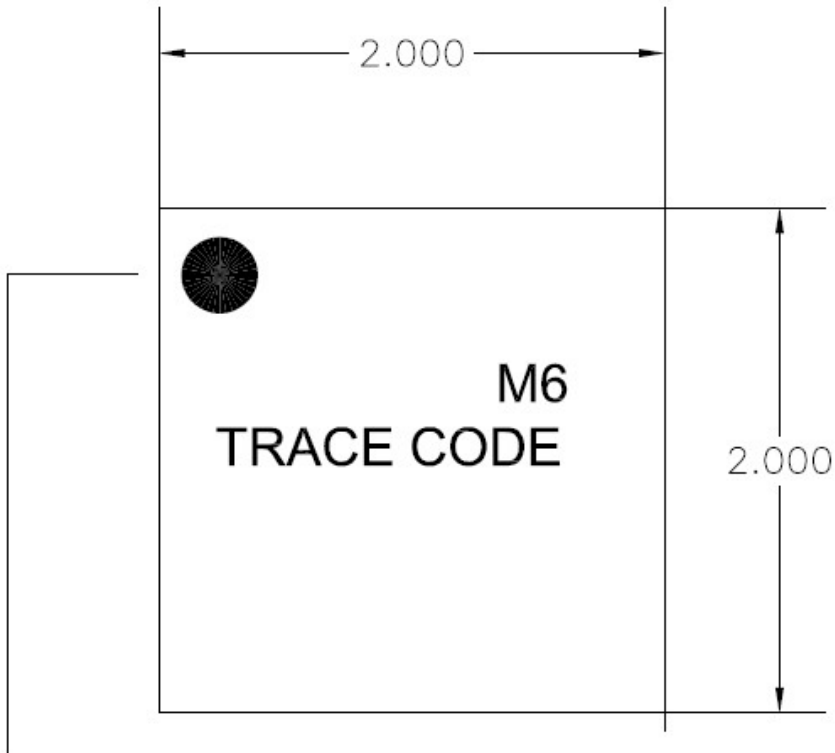

Pin 1 Indicator

Trace Code to be assigned by SubCon
