

### Product Overview

The QPC8015Q is a low insertion loss, high isolation single-pole dual-throw (SPDT) switch with performance optimized for low power routing and diversity applications. The QPC8015Q is controlled by 1 bit GPIO with a compact 0.7mm x 1.1mm x 0.59mm size, which allows for a small solution size with no need for external DC blocking capacitors.

### Functional Block Diagram

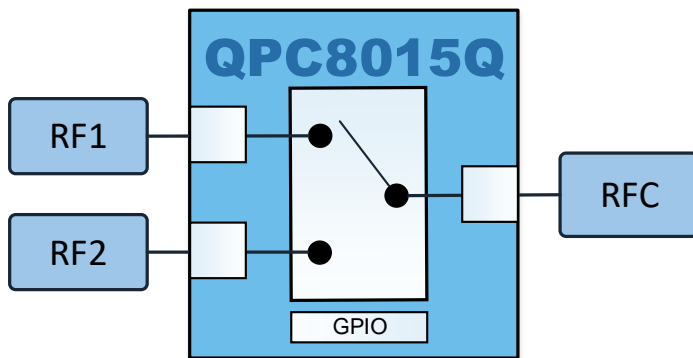

Top View

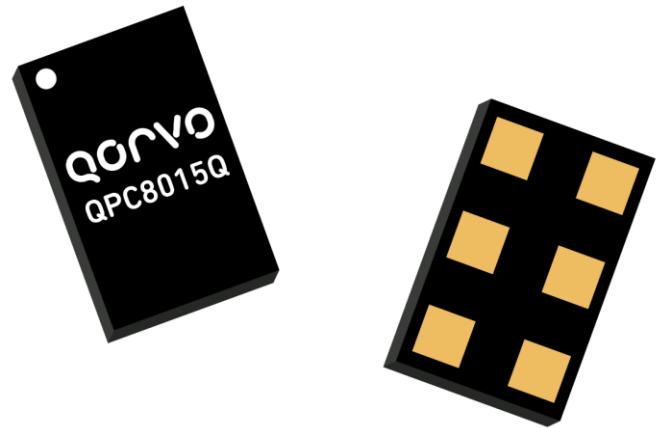

6 Pin 1.1 x 0.7 X 0.59 mm<sup>3</sup> Module

### Key Features

- Qualified to AEC-Q100 Grade 3
- Low Insertion Loss
- High Isolation
- One Bit Controller Only
- Broadband Performance designed for Modulation Schemes up to 6GHz covering n77/78/79 and V2X
- Compact Size
- No DC Blocking Capacitors Required in Typical Applications

### Applications

- Automotive Telematics Modules
- Multi-Mode GSM, EDGE, WCDMA, and LTE Receive Applications

### Ordering Information

PART NUMBER	DESCRIPTION
QPC8015QEVB	Fully Assembled EVB
QPC8015QSB	Sample Bag with 5 pcs
QPC8015QSR	Sample Reel with 100 pcs
QPC8015QTR13	Standard 13" Reel with 10,000 pcs

## Absolute Maximum Ratings

PARAMETER	CONDITIONS	RATING
Storage Temperature		-40 to +125 °C
V <sub>DD</sub>		6.0 V
CTRL Voltage		3.0 V
Maximum Input Power	1:1 VSWR, Continuous Wave +25°C	26 dBm

Operation of this device outside the parameter ranges given above may cause permanent damage.

## Recommended Operating Conditions

PARAMETER	MIN.	TYP.	MAX.	UNITS
Operating Ambient Temperature	-40	+25	+85	°C
V <sub>DD</sub> Supply Voltage	2.4	2.85	5.5	V
V <sub>DD</sub> Supply Current (Active Mode)		42	50	μA
CTRL Logic Voltage High	1.3	1.8	2.7	V
CTRL Logic Voltage Low	0.00	0.00	0.45	V
CTRL Logic Current High		70	300	nA
Switching Time - ON Switching speed 10% to 90% port to port		2	2.5	μs

Electrical specifications are measured at specified test conditions. Specifications are not guaranteed over all recommended operating conditions.

## Electrical Specifications<sup>(1)</sup>

Test conditions unless otherwise stated: all unused RF ports terminated in 50Ω, Input and Output = 50Ω, T = 25°C, V<sub>DD</sub> = 2.85V, CTRL = 1.8V

PARAMETER	CONDITIONS	MIN.	TYP.	MAX.	UNITS
<b>Frequency Range</b>		617		6000	MHz
<b>Insertion Loss</b>					
RFx - RFC	617MHz to 960MHz		0.3	0.4	dB
RFx - RFC	1427MHz to 2170MHz		0.4	0.65	dB
RFx - RFC	2300MHz to 2690MHz		0.45	0.7	dB
RFx - RFC	3300MHz to 4200MHz		0.6		dB
RFx - RFC	4400MHz to 5000MHz		0.75		dB
RFx - RFC	5100MHz to 6000MHz		0.95		dB

PARAMETER	CONDITIONS	MIN.	TYP.	MAX.	UNITS
<b>Isolation</b>					
Inactive RFx-RFC; RF1-RF2	617MHz to 960MHz	33	41		dB
	1427MHz to 2170MHz	28	34		dB
	2300MHz to 2690MHz	24	30		dB
	3300MHz to 4200MHz		26		dB
	4400MHz to 5000MHz		24		dB
	5100MHz to 6000MHz		21		dB

PARAMETER	CONDITIONS	MIN.	TYP.	MAX.	UNITS
<b>Harmonics</b>					
2 <sup>nd</sup> Harmonic	Freq = 824-915MHz; P <sub>IN</sub> = 15dBm		-101	-90	dBm
3 <sup>rd</sup> Harmonic			-101	-88	dBm
4 <sup>th</sup> Harmonic to 12.75GHz			-110		dBm
2 <sup>nd</sup> Harmonic	Freq = 1710-1980MHz; P <sub>IN</sub> = 15dBm		-93	-85	dBm
3 <sup>rd</sup> Harmonic			-98	-88	dBm
4 <sup>th</sup> Harmonic to 12.75GHz			-110		dBm

PARAMETER	CONDITIONS	MIN.	TYP.	MAX.	UNITS
<b>IMD2</b>					
	f1=20dBm f2=-15dBm: f1=836.5MHz f2=1718MHz		-105		dBm
	f1=20dBm f2=-15dBm: f1=1950MHz f2=4090MHz		-105		dBm
<b>IMD3</b>					
	f1=20dBm f2=-15dBm: f1=836.5MHz f2=791.5MHz		-105		dBm
	f1=20dBm f2=-15dBm: f1=1950MHz f2=1760MHz		-105		dBm

PARAMETER	CONDITIONS	MIN.	TYP.	MAX.	UNITS
<b>VSWR</b>					
Input/Output VSWR	617MHz to 960MHz		1.1		: 1
Input/Output VSWR	1427MHz to 2170MHz		1.1		: 1
Input/Output VSWR	2300MHz to 2690MHz		1.2		: 1
Input/Output VSWR	3300MHz to 4200MHz		1.5		: 1
Input/Output VSWR	4400MHz to 5000MHz		1.7		: 1
Input/Output VSWR	5100MHz to 6000MHz		2.0		: 1

<sup>1</sup> Recommended EVB schematic/ layout/ BOM/ PCB should be followed in order to achieve specified performance.

## Pin Configuration and Description



**Top View**

## Pin-out Description

PIN	NAME	DESCRIPTION
1	RF2	RF Port
2	GND	Ground
3	RF1	RF Port
4	VDD	Supply Voltage
5	RFC	RF Common Port
6	CTRL	Control

## Control Logic

MODE	CTRL	DESCRIPTION
RFC – RF1	Low	Active path is RFC-RF1, RF2 is low impedance/reflective
RFC – RF2	High	Active path is RFC-RF2. RF1 is low impedance/reflective

## Power On and Off Sequence

It is very important that the user adheres to the correct power-on/off sequence in order to avoid damaging the device. The control signals CTRL should be set to 0V unless V<sub>DD</sub> is set in the operating voltage range.

### Power Up Sequence:

- 1) Apply V<sub>DD</sub>
- 2) Apply CTRL
- 3) Apply RF

### Power Down Sequence: Reverse order of the power up sequence.

Not following the power up/down sequence may damage the device and affect long-term reliability.

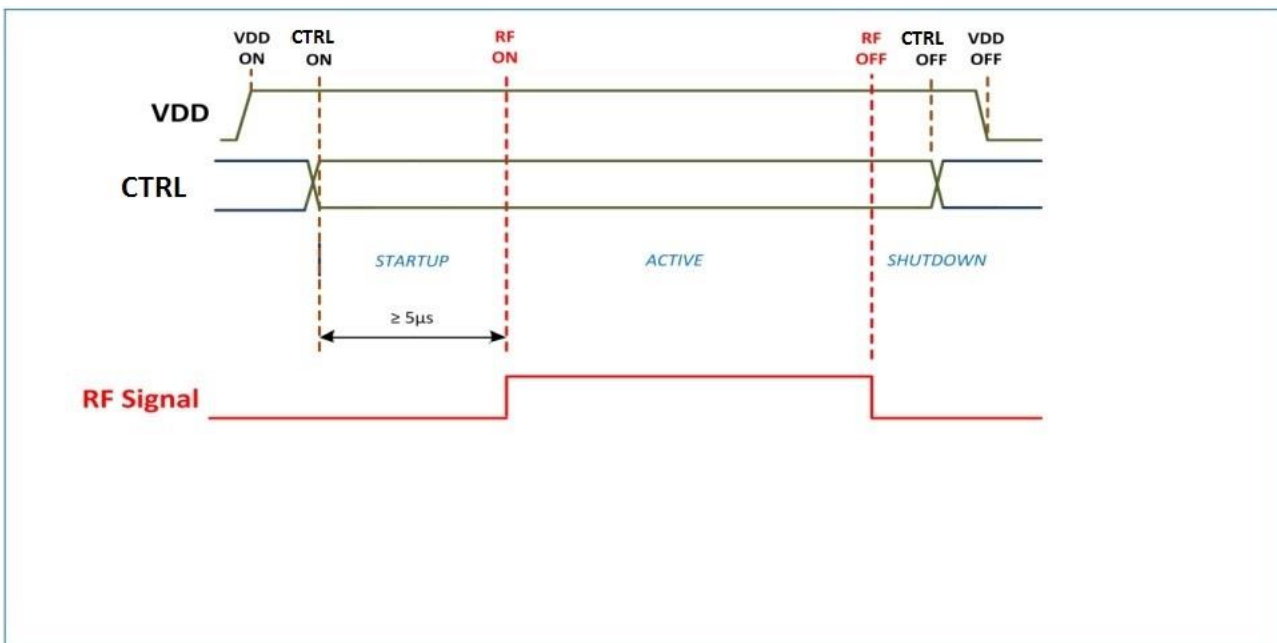

Evaluation Board Layout

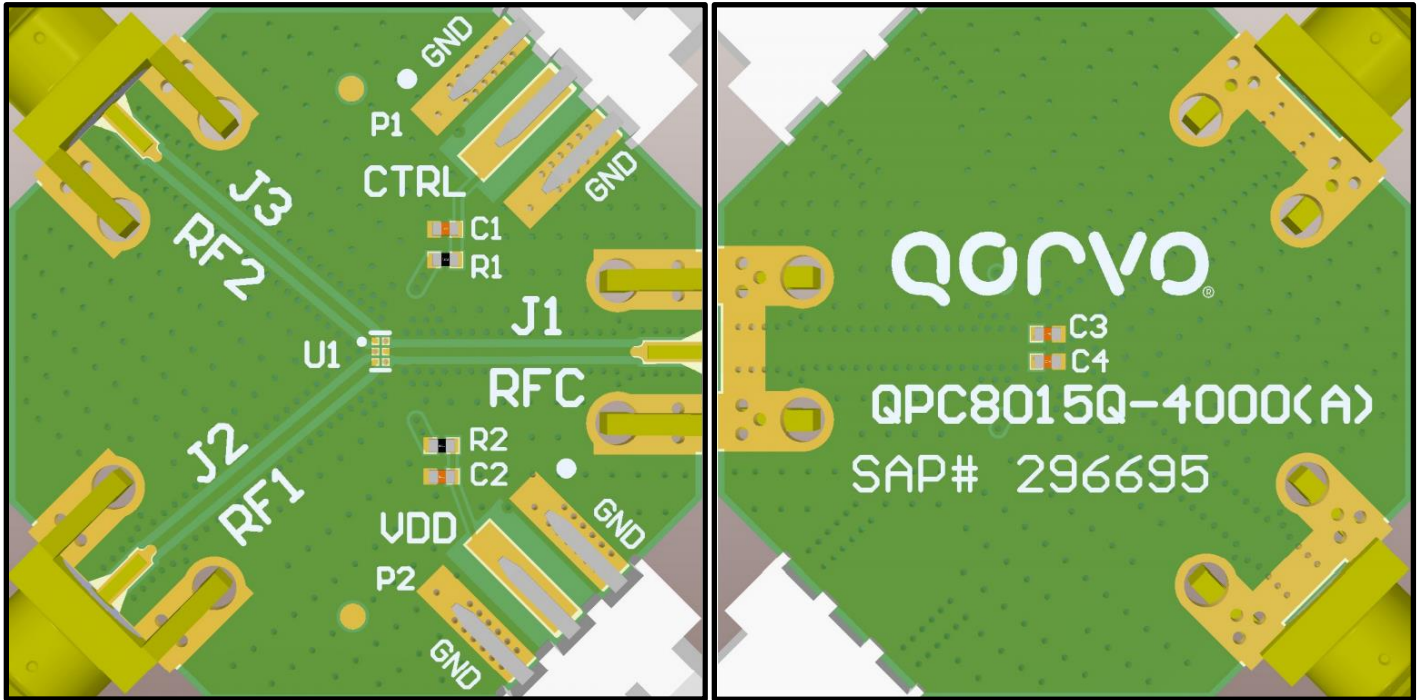

Evaluation Board Schematic

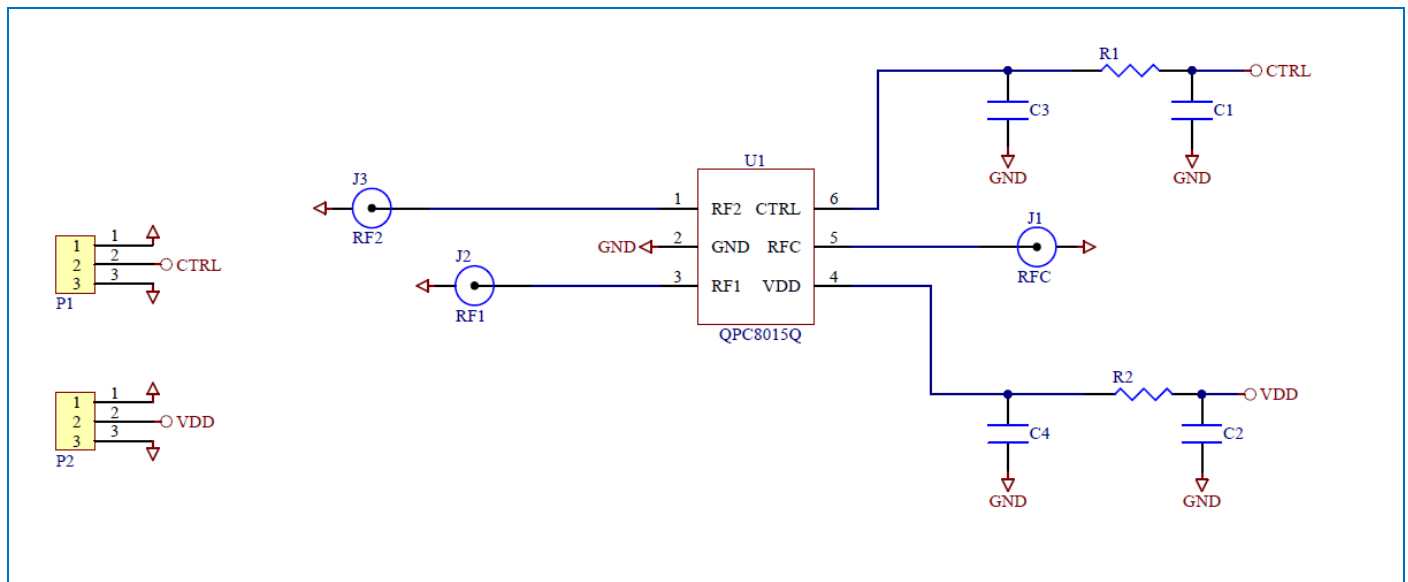

## Evaluation Board BOM

Qty	UOM	Ref Des	Description	Mfg Name	Mfg Part #
1	EA	PCB	PCB, QPC8015Q	TTM TECHNOLOGIES INC	QPC8015Q-4000(A)
1	EA	C2	CAP, 2200pF, 10%, 50V, X7R, 0402	TAIYO YUDEN (SINGAPORE) PTE LTD	RM UMK105BJ222KV-F
2	EA	C3,C4	CAP, 10pF, 5%, 50V, HI-Q, 0402	MURATA ELECTRONICS SINGAPORE PTE LT	GJM1555C1H100JB01D
1	EA	C1	CAP, 100pF, 10%, 50V, STD, 0402	AVX Asia Limited	04025C101KAT2A
2	EA	R1,R2	RES, 0 OHM, 5%, 1/10W, 0402	Kamaya, Inc	RMC1/16SJPTH
2	EA	P1,P2	CONN, HDR, ST, 3-PIN, 0.100"	SAMTEC INC.	TSW-103-07-G-S
3	EA	J1,J2,J3	CONN, SMA, EL MINI FLT 0.068" SPE-000303	Aliner Industries, Inc.	20-001CF-T

## Evaluation Board RF Performance

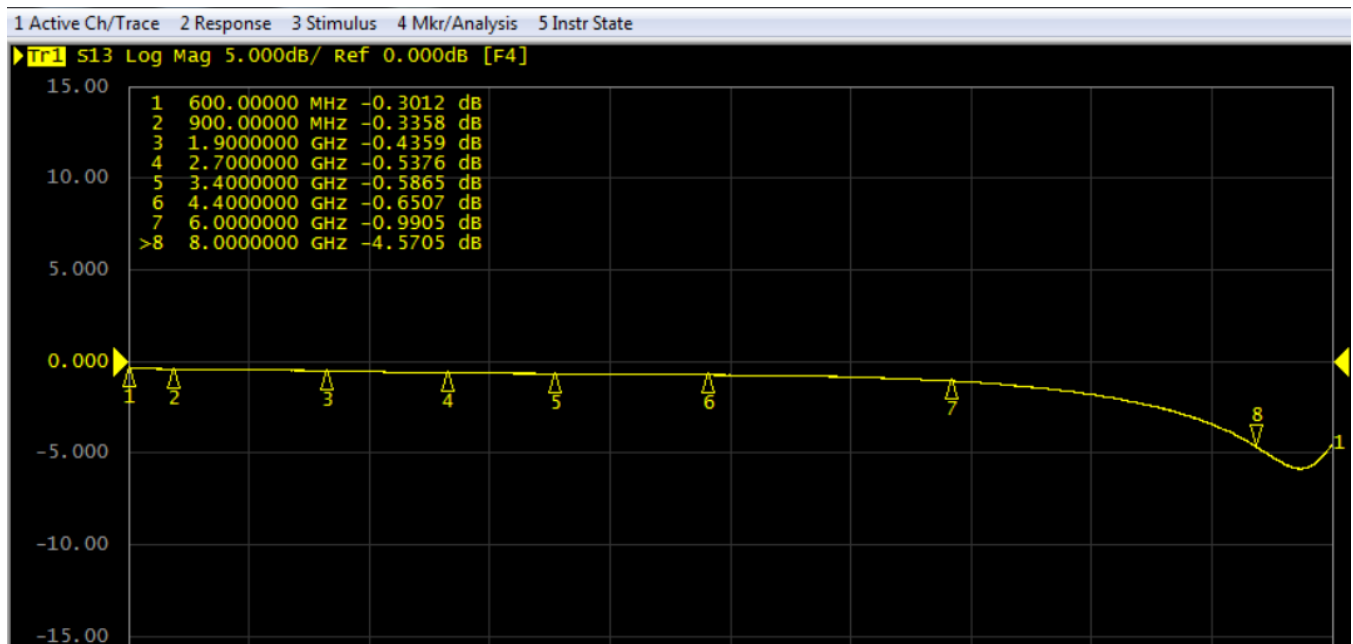



Evaluation Board PCB Information

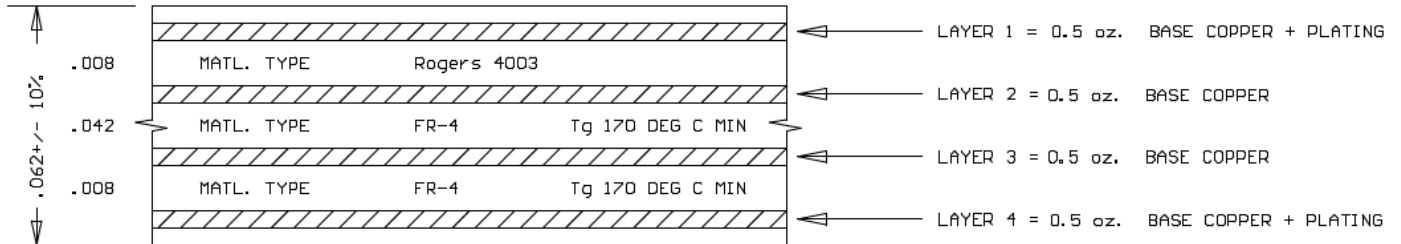

CONTROLLED IMPEDANCE:  YES  NO

MICROSTRIP LAYER 1: 14.00 +/-0.0005 REF LAYER 2  
 TARGET IMPEDANCE: 50 OHMS +/-5%  
 TARGET FREQUENCY: 900, 1800, 2800 and out to 12750MHZ  
 DIELECTRIC CONSTANT: 3.38

\* DIELECTRIC(S) THAT CAN BE ADJUSTED TO OBTAIN FINISHED THICKNESS:  
 LAYER 2-4

\* GERBER DATA SUPPLIED WITH DESIRED FINAL TRACE WIDTHS. PROCESS  
 COMPENSATION TRACE WIDTH ADJUSTMENT TO BE DONE BY PCB FABRICATOR.

Marking Diagram

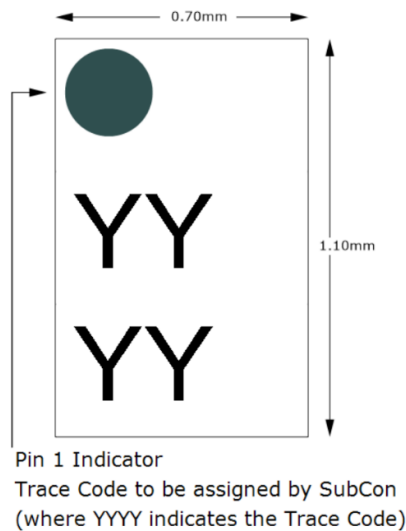

Package Drawing

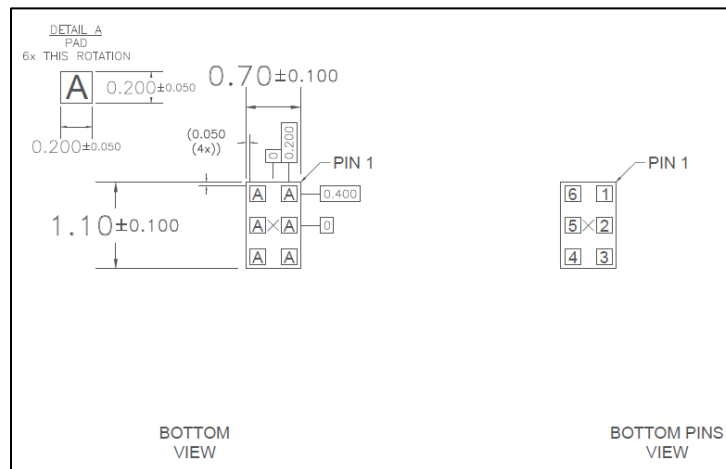
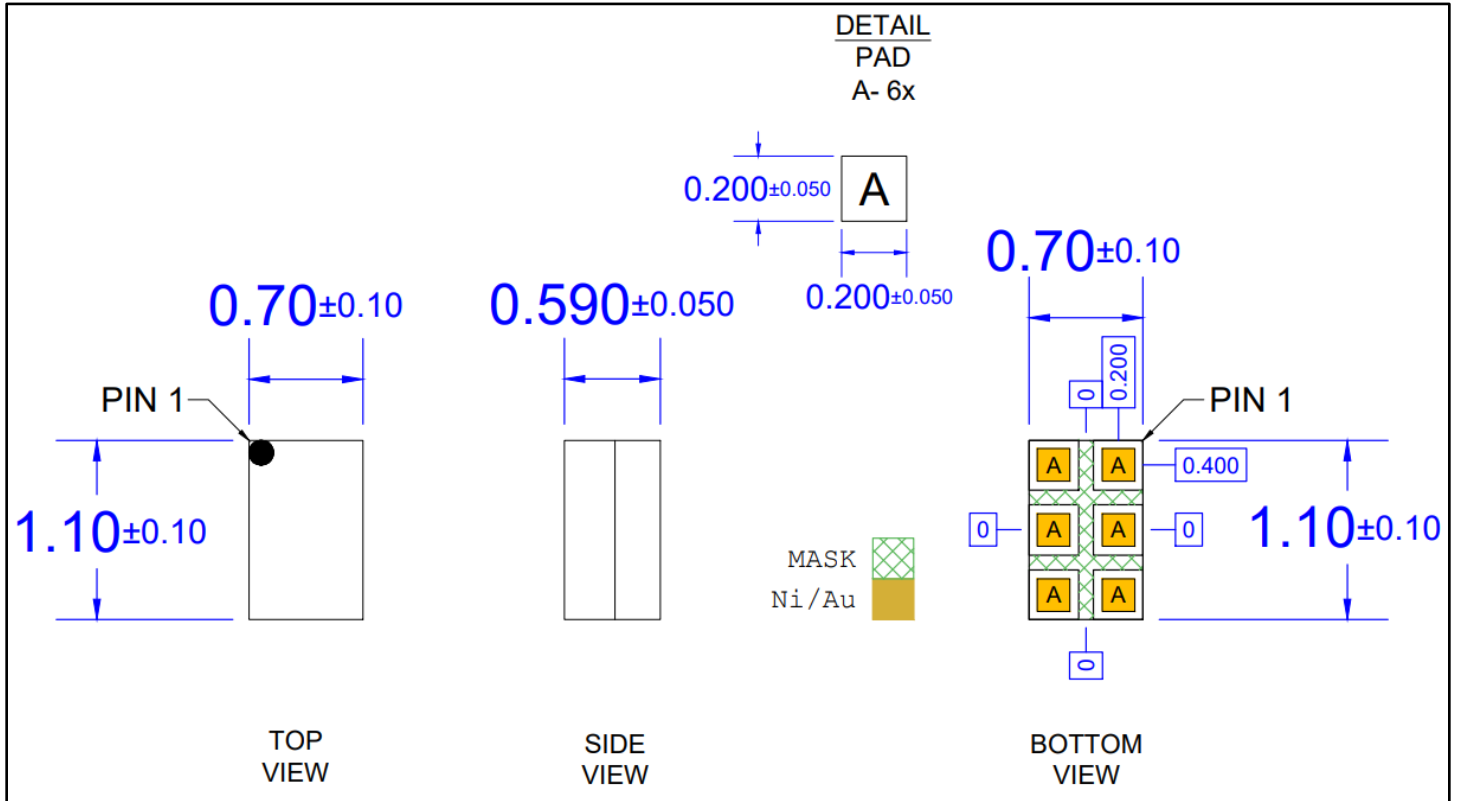

PCB Pattern

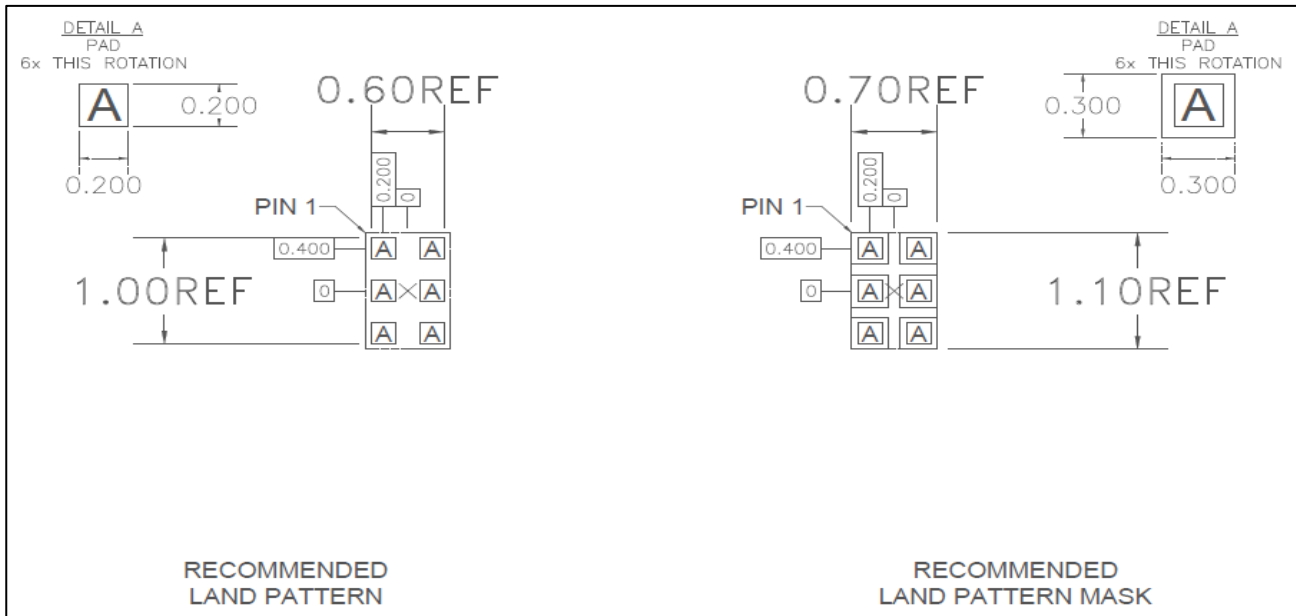
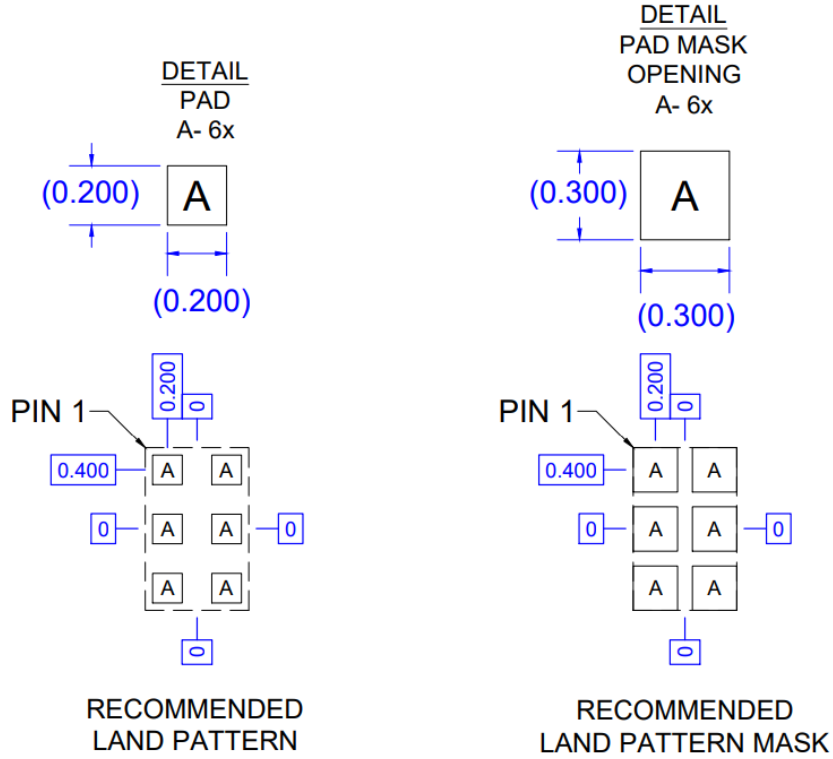

**Tape and Reel Information**

**Tape and Reel**

QORVO Part Number	Reel Diameter Inch (mm)	Hub Diameter Inch (mm)	Width (mm)	Pocket Pitch (mm)	Feed	Units Per Reel
QPC8015QTR13-10K	13 (330)	4 (102)	8	4	Single	10000

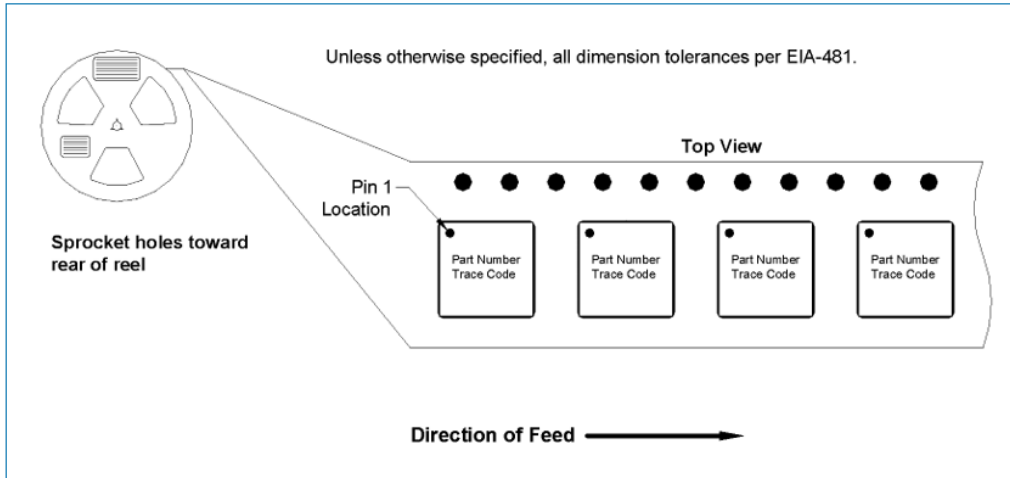

**0.70mm x 1.10mm (Carrier Tape Drawing with Part Orientation)**

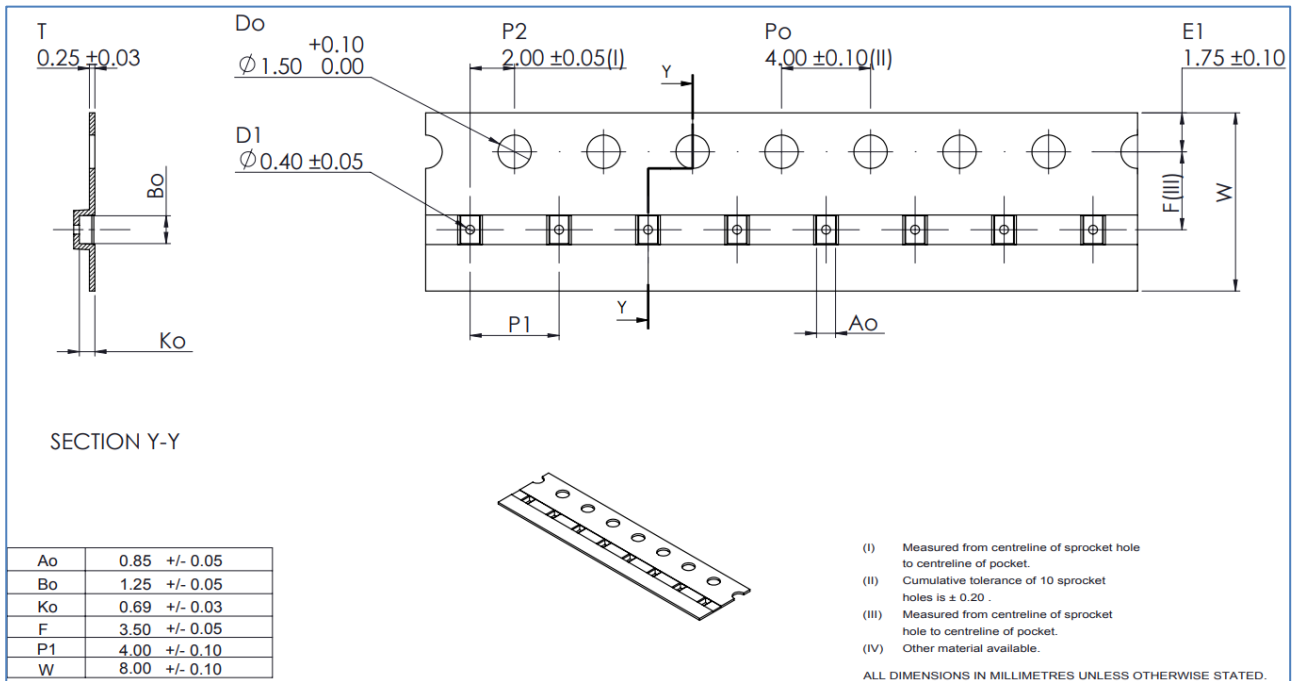

## Handling Precautions

PARAMETER	RATING	STANDARD
ESD – Human Body Model (HBM)	1500V or 1C	ANSI/ESD/JEDEC JS-001
ESD – Charged Device Model (CDM)	1500V or C3	JEDEC JESD22-C101F
MSL – Moisture Sensitivity Level	MSL 3	IPC/JEDEC J-STD-020



Caution!

ESD sensitive device

## Solderability

Compatible with both lead-free (260 °C max. reflow temperature) and tin/lead (245 °C max. reflow temperature) soldering processes.

Package lead plating: ENEPIG

## RoHS Compliance

This part is compliant with the 2011/65/EU RoHS directive (Restrictions on the Use of Certain Hazardous Substances in Electrical and Electronic Equipment), as amended by Directive 2015/863/EU.

This product also has the following attributes:

- Lead free
- Halogen Free (Chlorine, Bromine)
- Antimony Free
- TBBP-A (C<sub>15</sub>H<sub>12</sub>Br<sub>4</sub>O<sub>2</sub>) Free
- SVHC Free
- PFOS Free