

### Features

- WPC Qi V1.2.4 certified 10W wireless charging pad.
- Compatible with all Qi RX devices.
- Wireless fast charge to Apple iPhones and Samsung phones.
- Supports multiple size mobile phones
- Swivel ball head provide 360° rotation to any angle.
- Flexible soft rubber arm lock with one hand access (put in & take out) while protecting your phone from any scratches.
- USB Type-C Jack.



### Input Characteristics

- Input Voltage & Frequency

Item	Minimum	Normal	Maximum
Input Voltage	4.75VDC	9.0VDC	9.5VDC

Charging Mode	Qi 5W	Qi 10W	Samsung Fast Charger	iPhone Fast Charger
Frequency	110 ~ 205 kHz			127.7kHz ± 0.4kHz

- Input Current
 

1.65A max. @ 5.0VDC	Full load
1.75A max. @ 9.0VDC	Full load
- Rush Current (cold)
 

1.85A max. @ 5.0VDC	Full load & Ambient temperature 25°C
2.00A max. @ 9.0VDC	Full load & Ambient temperature 25°C
- Energy Consumption ≤ 0.625W at 4.75VDC or 9.0VDC

### Output Characteristics

- Output Mode at the Receiving End

TX Input Voltage	Charging Mode (RX)			
	Qi 5W	Qi 10W	Samsung Fast Charger	iPhone Fast Charger
QC2.0 / QC3.0	✓	✓	✓	✓

### Protection Requirement

- Short Circuit Protection  
When the output of RX is short-circuited, the input power should decrease or stop supplying so that the power supply will not be damaged. And it should automatically recover when the fault is resolved.
- Over Current Protection (OCP)  
OCP Point Limited : 120%~130% auto restart  
When the output at the receiving end exceeds the OCP point, the current output should stop immediately; and is restored when the fault is resolved.

### Reliability Requirements

- Reliability Test

Test items	Test conditions
Storage at high temperature test	+60°C, 16hours
Storage at low temperature test	-20°C, 16hours
Operating at high temperature test	+40°C, 8hours
Operating at low temperature test	-20°C, 8hours
High / Low temperature cycle test	+40°C (2Hrs) → -20°C (2Hrs) → +40°C (2Hrs) → -20°C (2Hrs) continually work 24hours

- Burn-in : 2 hours under +35°C (±5°C), nominal input voltage, nominal load.

### Environment Requirement

- Operating Temperature and Relative Humidity  
0°C to +40°C, 20%RH to 80%RH @ altitude shall be below 10000 feet.
- Storage Temperature and Relative Humidity  
-20°C to +60°C, 10%RH to 90%RH (non-condensing) @ altitude shall be below 30000 feet.

### Execution Standards (Compatible with these specifications)

- EMC Standards

EN55032	EN55024	FCC-Part15
---------	---------	------------

### Product Picture

- Wireless charging base pad :

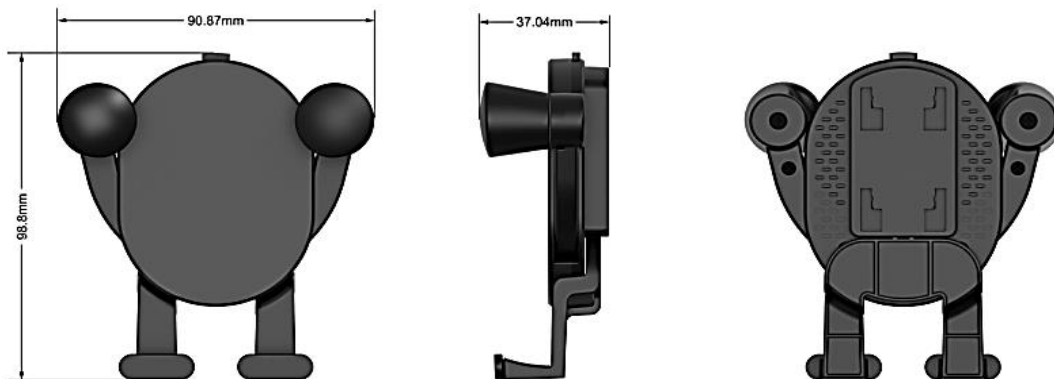

Weight : 76g ± 5g

### Others

- 1m USB to USB-C cable included.
- The car mount come with a suction stand or cup stand or air vent clamp or air vent clip. Please refer to the "Ordering Information".