

Product Overview

The QPD1034 is a 1700 W (P_{3dB}) fully matched GaN RF pallet which operates from 0.96 to 1.215 GHz on a 65 V supply rail. The pallet uses GaN on SiC HEMT technology and is ideally suitable for IFF, avionics and test instrumentation. The pallet can support pulsed operations.

Pallets are available upon request.

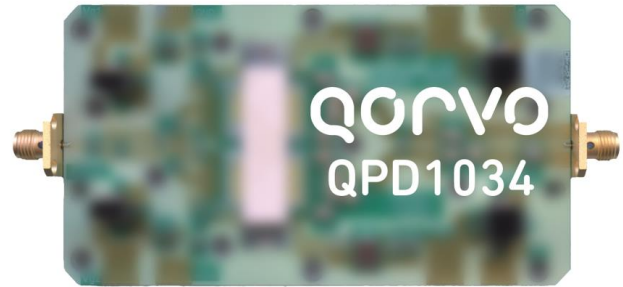

Key Features

- Operating Frequency: 0.96 to 1.215 GHz
- Operating Voltage: 65 V
- Linear Gain: 19.4 dB ⁽¹⁾
- Output Power (P_{3dB}): 1734 W ⁽¹⁾
- Drain Efficiency (P_{3dB}): 61.6% ⁽¹⁾
- Pulse Operations
- Pallet EVB Size: 4.250" x 2.235" x 0.640"

Notes:

(1) Pallet Performance @ 1.15 GHz

Functional Block Diagram

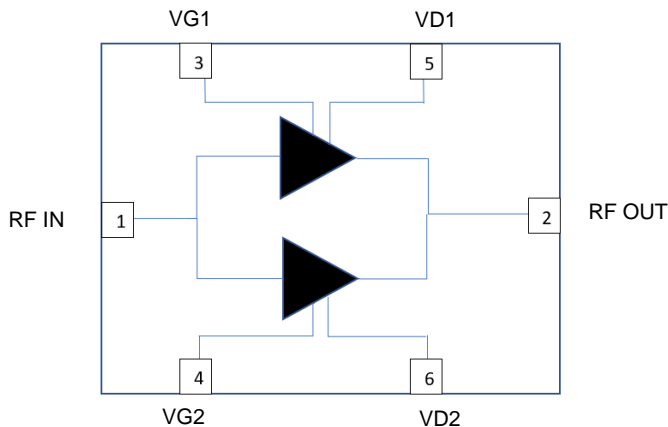

Applications

- DME Radar
- IFF Transponders
- Avionics

Ordering Information

Part No.	Description
QPD1034	0.96 – 1.215 GHz GaN RF Pallet

Absolute Maximum Ratings ^{1, 2, 3}

Parameter	Rating	Units
Breakdown Voltage, BV_{DG}	225	V
Gate Voltage Range, V_G	-7 to +2	V
Drain Current, $I_{D_{MAX}}$	142	A
Power Dissipation, Pulsed, P_{DISS}^2	1209	W
RF Input Power, Pulsed, P_{IN}^3	46.2	dBm
Storage Temperature	-65 to +150	°C

Notes:

1. Operation of this device outside the parameter ranges given above may cause permanent damage
2. Pulsed, 1000us PW, 20% DC, Package base at 85 °C
3. Pulsed, 100us PW, 10% DC, T = 25 °C

Recommended Operating Conditions

Parameter	Min	Typ	Max	Units
Operating Temp. Range	-40	+25	+85	°C
Drain Voltage Range, V_D		+65		V
Drain Bias Current, I_{DQ}		1.5		A
Drain Current, I_D		28		A
Gate Voltage, V_G		-2.8		V
Power Dissipation, P_{DISS} , Pulsed			685	W

Electrical performance is measured under conditions noted in the electrical specifications table. Specifications are not guaranteed over all recommended operating conditions

RF Characterization – 0.96 – 1.215 GHz Pallet Performance at 1.15 GHz ^{1, 2}

Parameter	Min	Typ	Max	Units
Linear Gain, G_{LIN}	–	19.4	–	dB
Output Power at 3dB compression point, P_{3dB}	–	1734	–	W
Drain Efficiency at 3dB compression point, DE_{3dB}	–	61.6	–	%
Gain at 3dB compression point, G_{3dB}	–	16.4	–	dB
Gate Leakage $V_D = +10$ V, $V_G = -3.7$ V	-40	–	–	mA

Notes:

1. $V_D = 65$ V, $I_{DQ} = 1.5$ A (combined), Temp = +25 °C, Pulse Width = 100 μ s, Duty Cycle = 10%
2. Gate Leakage per path

RF Characterization – Impedance Mismatch at 1.0 GHz ^{1, 2, 3}

Symbol	Parameter	dB Compression	Typical
VSWR	Impedance Mismatch	3	2:1

Notes:

1. Test conditions unless otherwise noted: $V_D = 65$ V, $I_{DQ} = 1.5$ A (combined), Temp = +25 °C
2. Input drive power is determined at pulsed 3dB compression under matched condition at EVB output connector
3. Pulse: 100us, 10% Duty cycle

Thermal and Reliability Information – Pulsed ¹

Peak IR Surface Temperature vs. Pulse Width
Pallet base fixed at 85 °C, Pdiss Varies

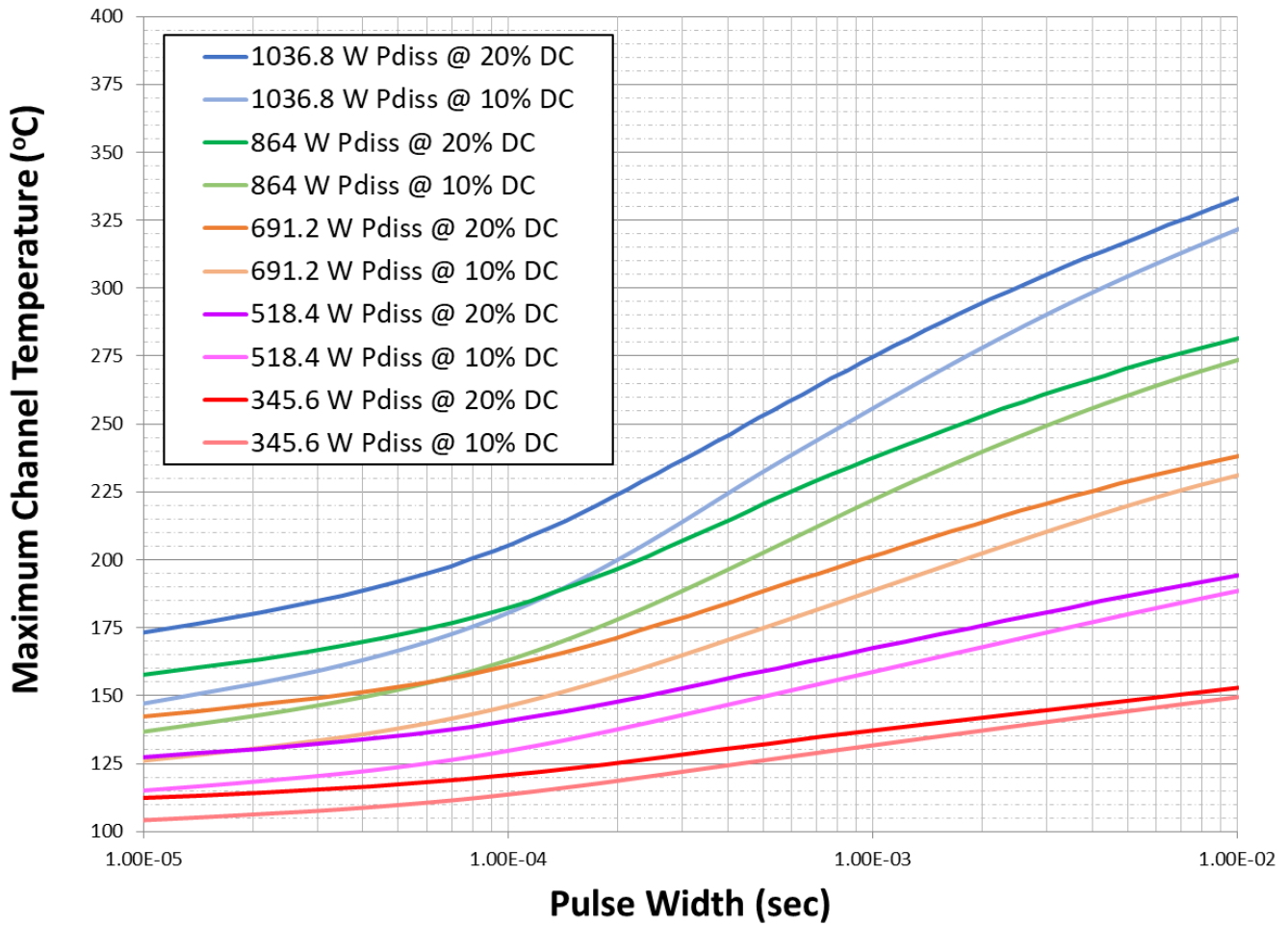

Parameter	Conditions	Values	Units
Thermal Resistance, IR ¹ (θ_{JC})	85 °C Pallet Backside Temperature	0.087	°C/W
Peak IR Surface Temperature ¹ (T_{ch})	Pdiss = 691.2 W, Pulse: 100 us PW, 10% DC	145	°C

Notes:

1. Refer to the following document [GaN Device Channel Temperature, Thermal Resistance, and Reliability Estimates](#)

Mechanical Drawing¹⁻²

Notes:

1. All dimensions are in inches.
2. Dimension tolerance is ± 0.005 inches, unless noted otherwise.

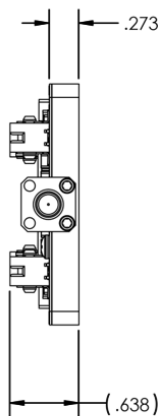
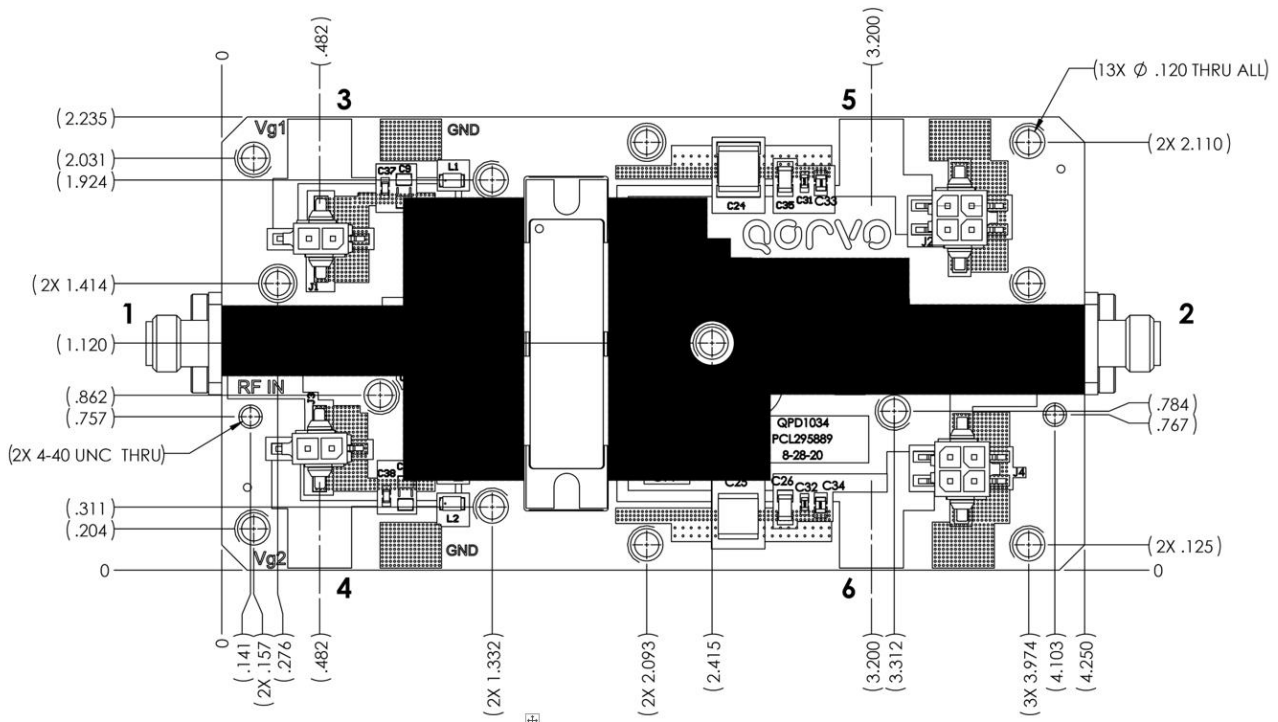

Pin	Symbol	Description
1	RF IN	RF Input
2	RF OUT	RF Output
3	VG1	Gate Voltage 1
4	VG2	Gate Voltage 2
5	VD1	Drain Voltage 1
6	VD2	Drain Voltage 2

P3dB Performance over Temperature of 0.96 – 1.215 GHz Pallet

Test Conditions unless otherwise noted: $V_D = 65\text{ V}$, $I_{DQ} = 1.5\text{ A}$, 100 us Pulse Width, 10% Duty Cycle,

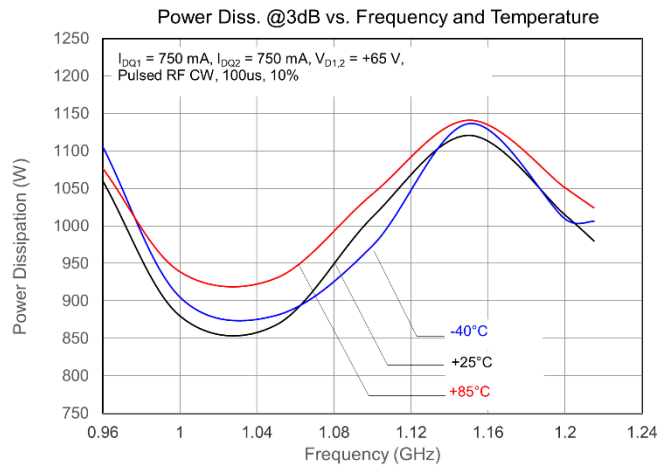
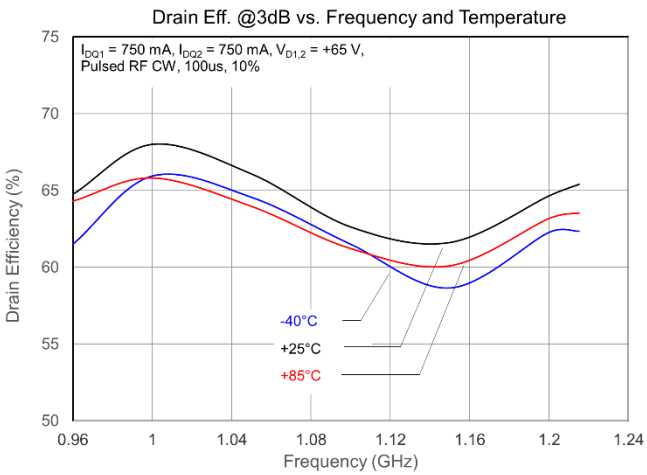
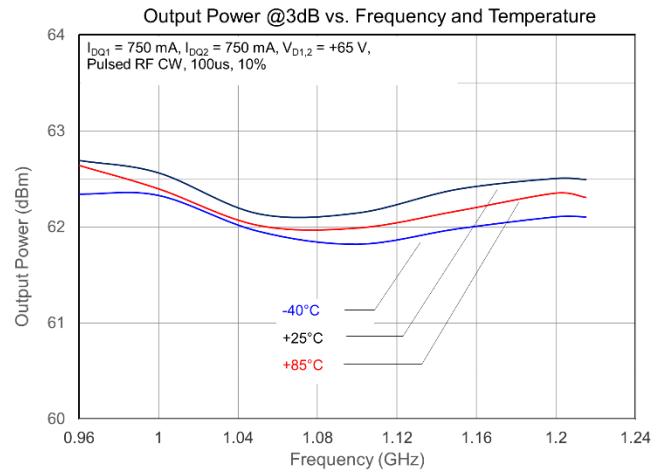
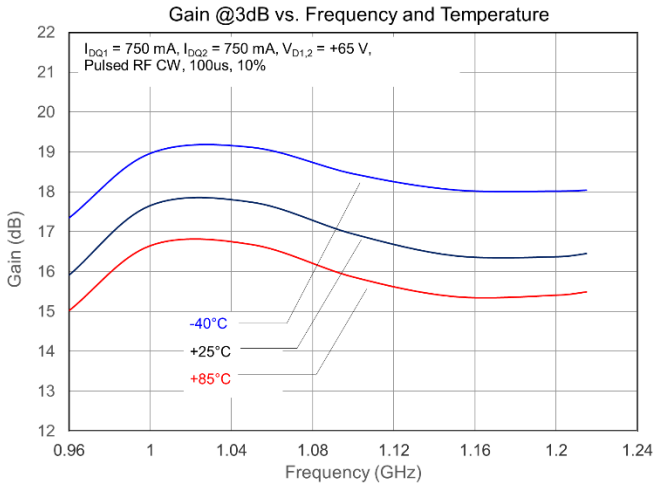

Power Drive-up Performance over Temperature of 0.96 – 1.215 GHz Pallet

Test Conditions unless otherwise noted: $V_D = 65\text{ V}$, $I_{DQ} = 1.5\text{ A}$, 100 μs Pulse Width, 10% Duty Cycle

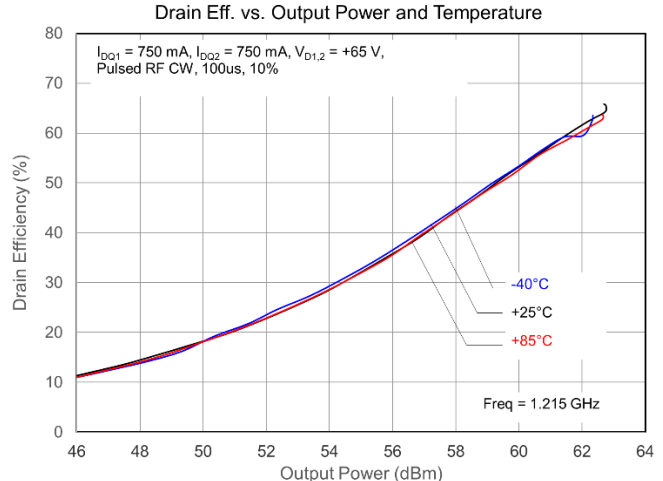
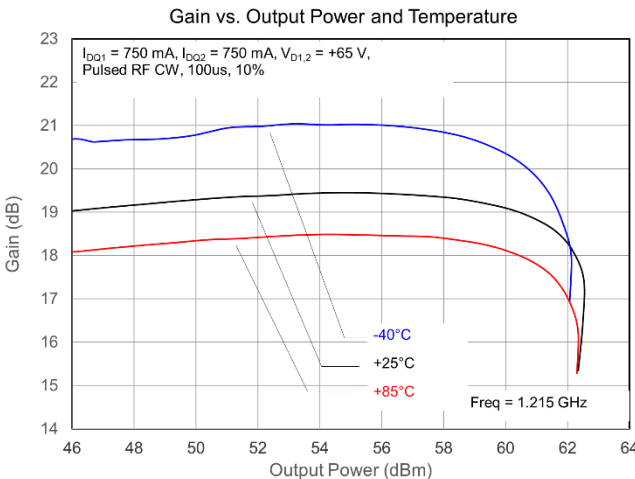
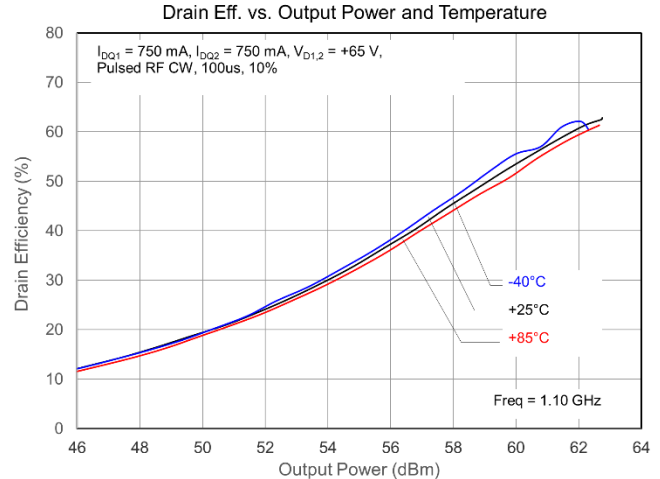
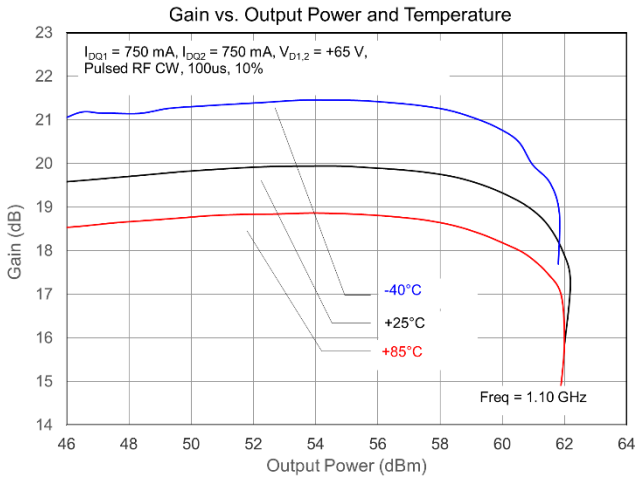
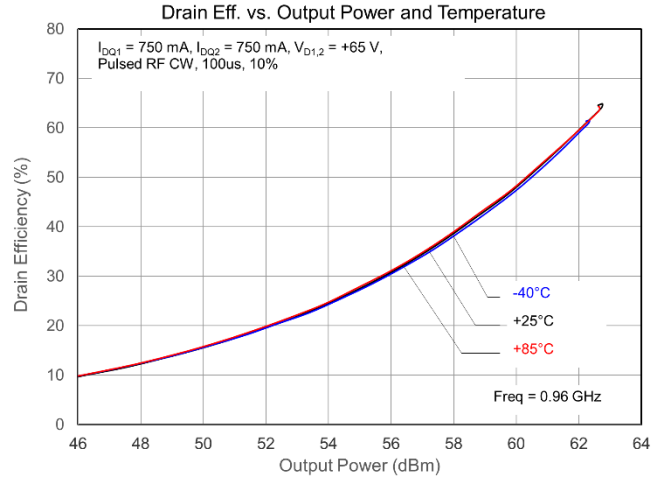
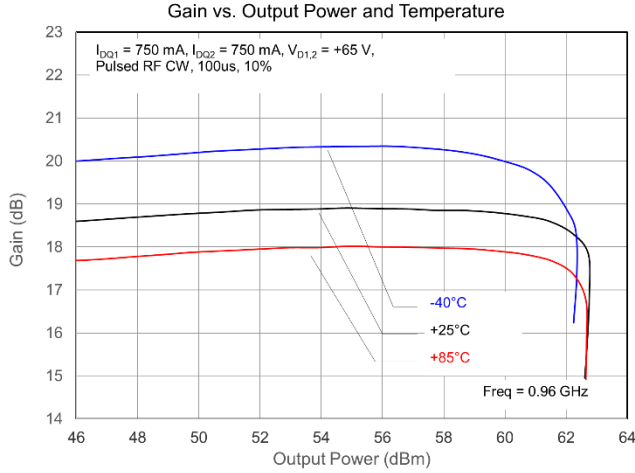

S-Parameters of 0.96 – 1.215 GHz Pallet over Temperature

Test Conditions unless otherwise noted: $V_D = 65\text{ V}$, $I_{DQ} = 1.5\text{ A}$.

