

Product Overview

The QPD9300 is a 30 W (P_{3dB}) internally matched discrete GaN on SiC HEMT which operates from 9.2 to 9.7 GHz and a 28 V supply rail. The device is fully matched to 50 Ω in an industry standard air cavity package and is ideally suited for military and civilian radar. The device can support pulsed and linear operations.

ROHS compliant.

Evaluation boards are available upon request.

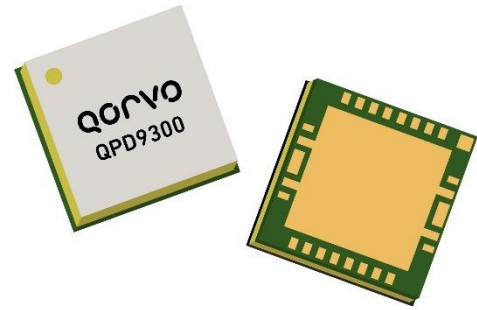

Functional Block Diagram

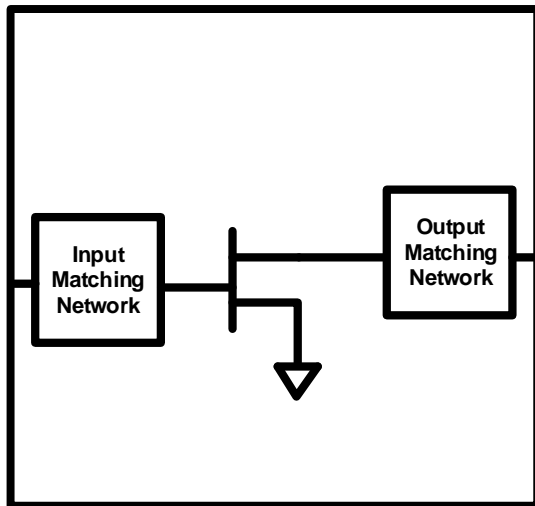

Key Features

- Frequency: 9.2 to 9.7 GHz
 - Output Power (P_{OUT})¹: 34.3 W
 - Gain¹: 9.1 dB
 - Typical DEFF¹: 48.6 %
 - Operating Voltage: 28 V
 - Low thermal resistance package
 - Pulse capable
- Note 1: @ 9.4 GHz and 37 dBm EVB input power

Applications

- Marine radar
- Civilian radar

Part No.	Description
QPD9300EVB3	9 – 10 GHz EVB
QPD9300SR	QPD9300 short reel of 100 parts.
QPD9300TR7	QPD9300 7" reel of 500 parts.



QPD9300

30 W, 28 V, 9.2 – 9.7 GHz, GaN RF IMFET

Absolute Maximum Ratings¹

Parameter	Rating	Units
Breakdown Voltage, BV_{DG}	+145	V
Gate Voltage Range, V_G	-7 to +2	V
Drain Current	11	A
Gate Current Range, I_G	See page 4.	mA
Power Dissipation, 10% DC 1 mS PW, P_{DISS}	78	W
RF Input Power, 10% DC 1 mS PW, 9.4 GHz, $T = 25^\circ\text{C}$	+43	dBm
Mounting Temperature (30 Seconds)	320	$^\circ\text{C}$
Storage Temperature	-65 to +150	$^\circ\text{C}$

Notes:

1. Operation of this device outside the parameter ranges given above may cause permanent damage.

Recommended Operating Conditions¹

Parameter	Min	Typ	Max	Units
Operating Temp. Range	-40	+25	+85	$^\circ\text{C}$
Drain Voltage Range, V_D	+24	+28	+32	V
Drain Bias Current, I_{DQ}	-	240	-	mA
Drain Current, I_D	-	0.5	-	A
Gate Voltage, V_G^4	-	-2.8	-	V
Power Dissipation, Pulsed (P_D) ^{2, 3}	-	-	62	W
Power Dissipation, CW (P_D) ²	-	-	37	W

Notes:

1. Electrical performance is measured under conditions noted in the electrical specifications table. Specifications are not guaranteed over all recommended operating conditions.
2. Package base at 85°C
3. Pulse Width = 100 μS , Duty Cycle = 10%
4. To be adjusted to desired I_{DQ}

**RF Characterization – 9 – 10 GHz EVB Performance At 9.4 GHz¹**

Parameter	Min	Typ	Max	Units
Gain, G	–	7.8	–	dB
Output Power, P _{OUT}	–	30.4	–	W
Drain Efficiency, DEFF	–	43.1	–	%

Notes:

1. EVB Input Power = 37 dBm, V_D = +28 V, I_{DQ} = 240 mA, Temp = +25 °C, Pulse Width = 100 μS, Duty Cycle = 10%.

RF Characterization – 9 – 10 GHz EVB Performance At 9.5 GHz¹

Parameter	Min	Typ	Max	Units
Gain, G	–	7.6	–	dB
Output Power, P _{OUT}	–	29.2	–	W
Drain Efficiency, DEFF	–	41.8	–	%

Notes:

1. EVB Input Power = 37 dBm, V_D = +28 V, I_{DQ} = 240 mA, Temp = +25 °C, Pulse Width = 100 μS, Duty Cycle = 10%.

RF Characterization – 9 – 10 GHz EVB Performance At 9.6 GHz¹

Parameter	Min	Typ	Max	Units
Gain, G	–	7.5	–	dB
Output Power, P _{OUT}	–	28.2	–	W
Drain Efficiency, DEFF	–	39.7	–	%

Notes:

1. EVB Input Power = 37 dBm, V_D = +28 V, I_{DQ} = 240 mA, Temp = +25 °C, Pulse Width = 100 μS, Duty Cycle = 10%.

RF Characterization – Mismatch Ruggedness at 9.3 - 9.6 GHz^{1, 2}

Symbol	Parameter	Typical
VSWR	Impedance Mismatch Ruggedness	3:1

Notes:

1. Test conditions unless otherwise noted: T_A = +25 °C, V_D = 28 V, I_{DQ} = 240 mA, 1 mS PW, 10% DC
2. Driving input power is 43 dBm under matched condition at EVB input connector.

Maximum Gate Current

Maximum Gate Current vs. IR Surface Temperature

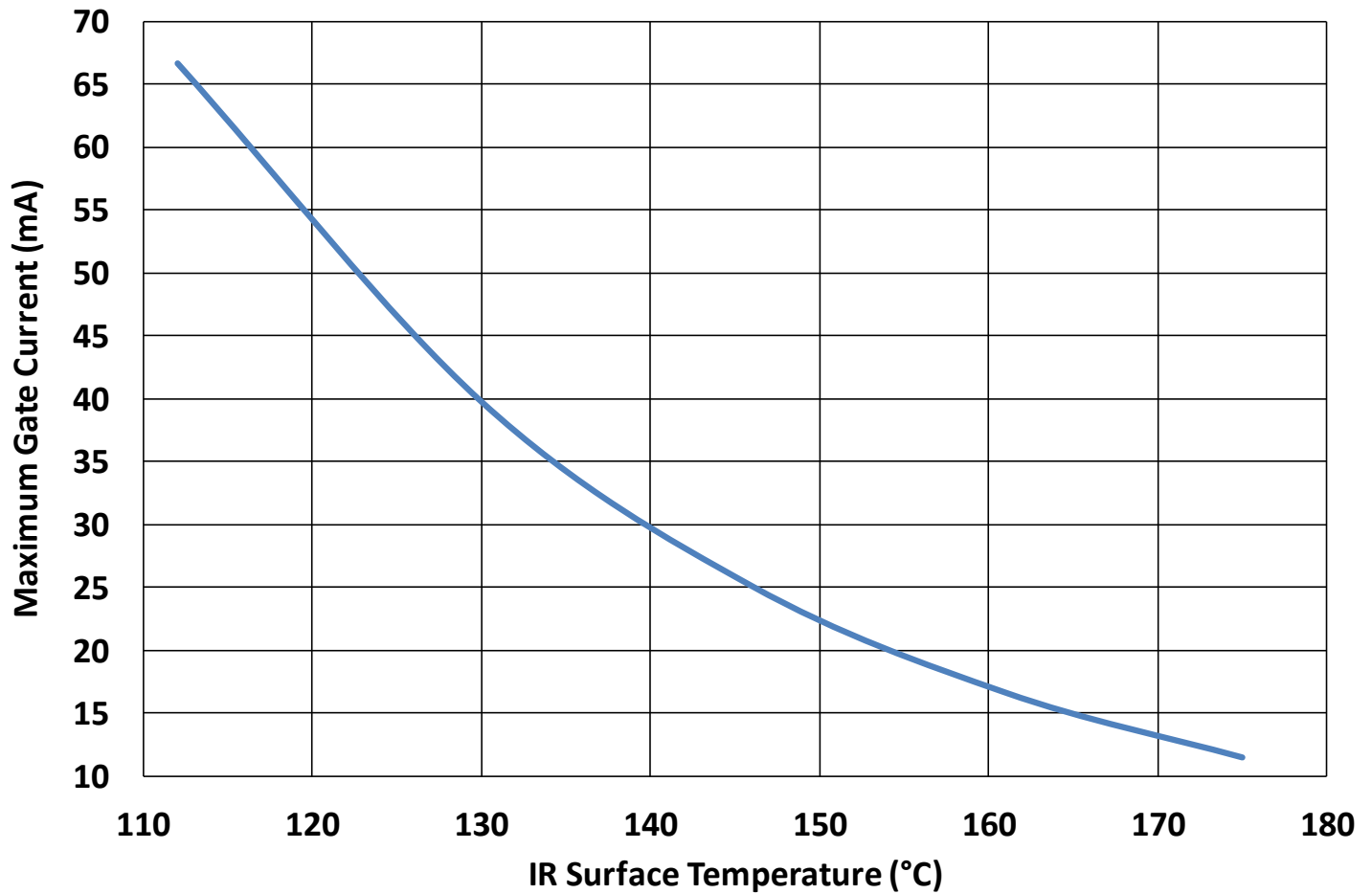

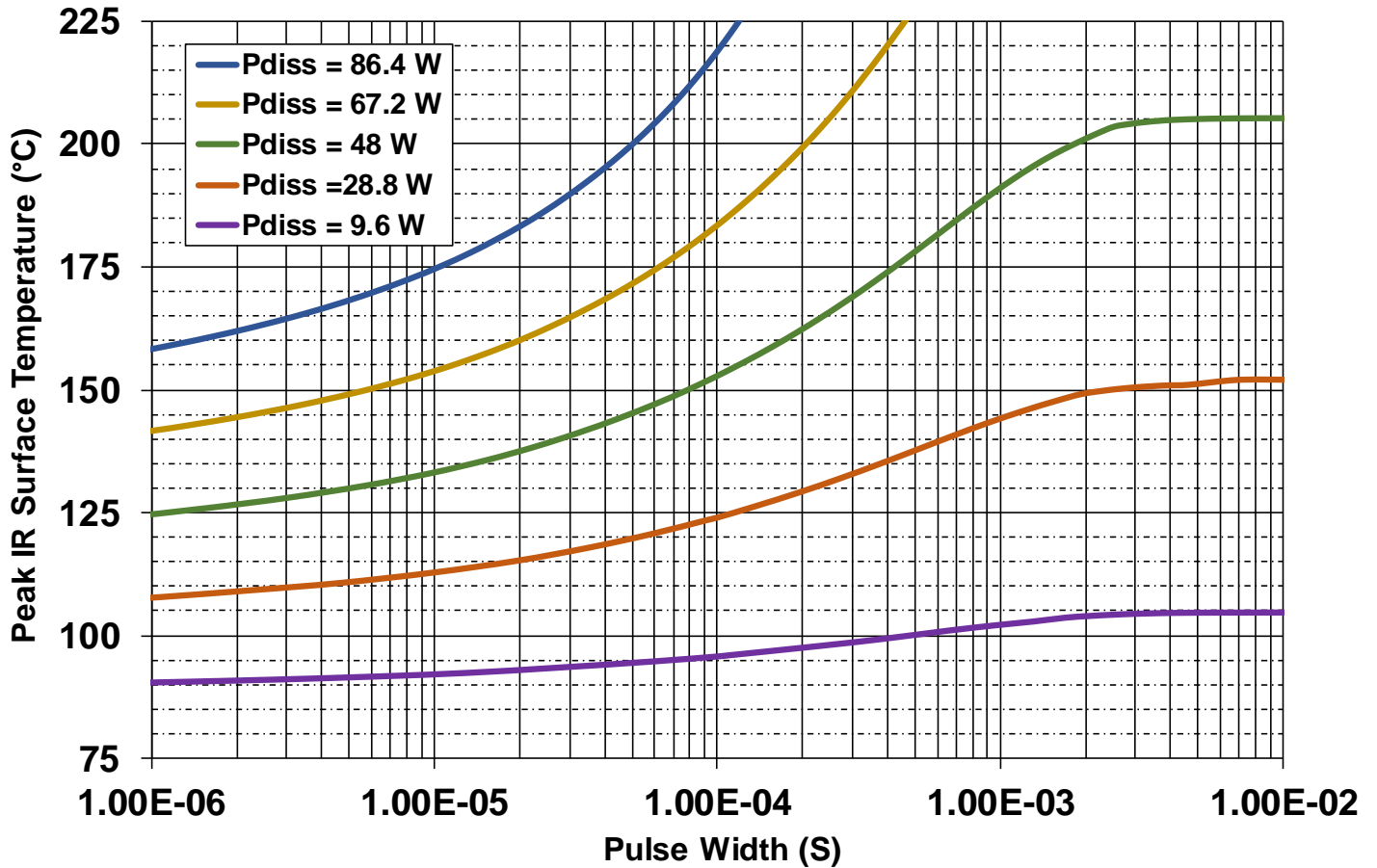
Thermal and Reliability Information – Pulsed¹
**Peak IR Surface Temperature vs. Pulse Width vs. Dissipation Power
10% Duty Cycle, Backside of Package At 85°C**

Parameter	Conditions	Values	Units
Thermal Resistance, IR (θ_{JC})	85 °C Case	1.15	°C/W
Peak IR Surface Temperature (T_{CH})	9.6 W Pdiss, 100 uS PW, 10% DC	96	°C
Thermal Resistance, IR (θ_{JC})	85 °C Case	1.35	°C/W
Peak IR Surface Temperature (T_{CH})	28.8 W Pdiss, 100 uS PW, 10% DC	124	°C
Thermal Resistance, IR (θ_{JC})	85 °C Case	1.42	°C/W
Peak IR Surface Temperature (T_{CH})	48 W Pdiss, 100 uS PW, 10% DC	153	°C
Thermal Resistance, IR (θ_{JC})	85 °C Case	1.46	°C/W
Peak IR Surface Temperature (T_{CH})	67.2 W Pdiss, 100 uS PW, 10% DC	183	°C
Thermal Resistance, IR (θ_{JC})	85 °C Case	1.54	°C/W
Peak IR Surface Temperature (T_{CH})	86.4 W Pdiss, 100 uS PW, 10% DC	218	°C

¹Refer to the following document [GaN Device Channel Temperature, Thermal Resistance, and Reliability Estimates](#)

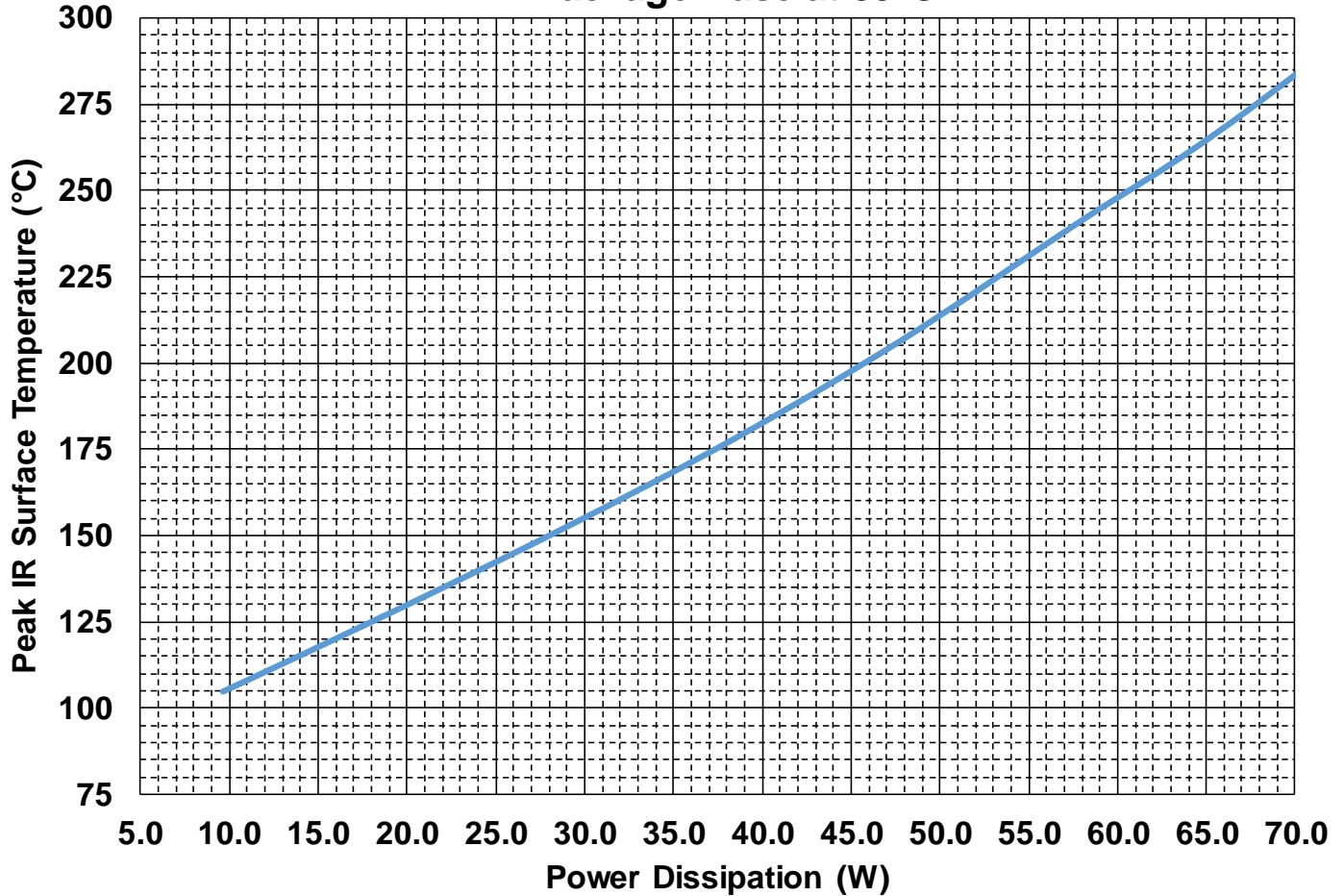
Thermal and Reliability Information – CW¹
**Peak IR Surface Temperature vs. Power
Package Base at 85°C**

Parameter	Conditions	Values	Units
Thermal Resistance, IR (θ_{JC})	85 °C Case	2.24	°C/W
Peak IR Surface Temperature (T_{CH})	19.2 W Pdiss, CW	128	°C
Thermal Resistance, IR (θ_{JC})	85 °C Case	2.33	°C/W
Peak IR Surface Temperature (T_{CH})	28.8 W Pdiss, CW	152	°C
Thermal Resistance, IR (θ_{JC})	85 °C Case	2.42	°C/W
Peak IR Surface Temperature (T_{CH})	38.4 W Pdiss, CW	178	°C
Thermal Resistance, IR (θ_{JC})	85 °C Case	2.54	°C/W
Peak IR Surface Temperature (T_{CH})	48 W Pdiss, CW	207	°C
Thermal Resistance, IR (θ_{JC})	85 °C Case	2.69	°C/W
Peak IR Surface Temperature (T_{CH})	57.6 W Pdiss, CW	240	°C

¹Refer to the following document [GaN Device Channel Temperature, Thermal Resistance, and Reliability Estimates](#)

S-Parameters Over Temperatures Of 9 – 10 GHz EVB¹

Notes:

1. $V_D = 28\text{ V}$, $I_{DQ} = 240\text{ mA}$.

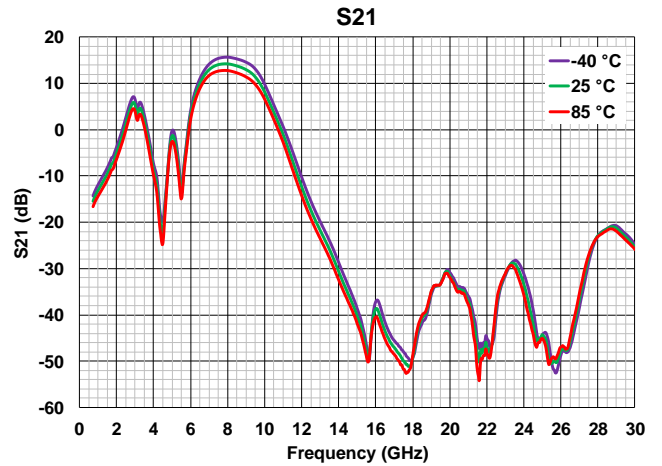
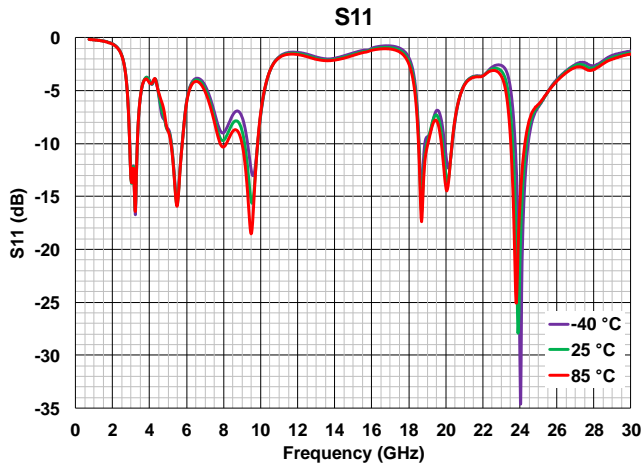

2.

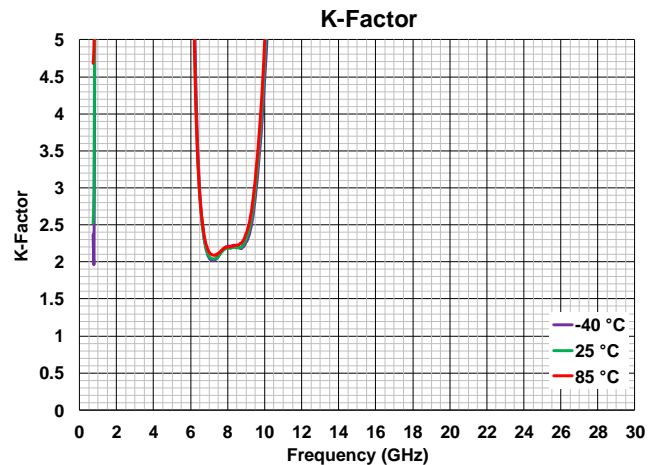
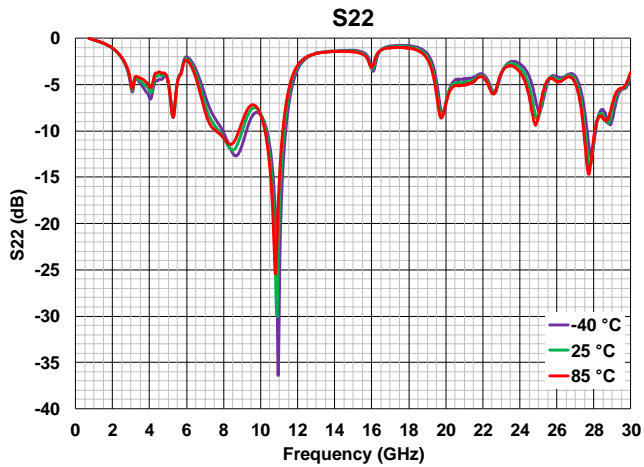

Power Performance Over Temperatures Of 9 – 10 GHz EVB^{1,2}

Notes:

1. At QPD9300 Package.
2. EVB Input Power = 37 dBm, $V_D = 28\text{ V}$, $I_{DQ} = 240\text{ mA}$, $100\ \mu\text{S PW}$, 10% DC.

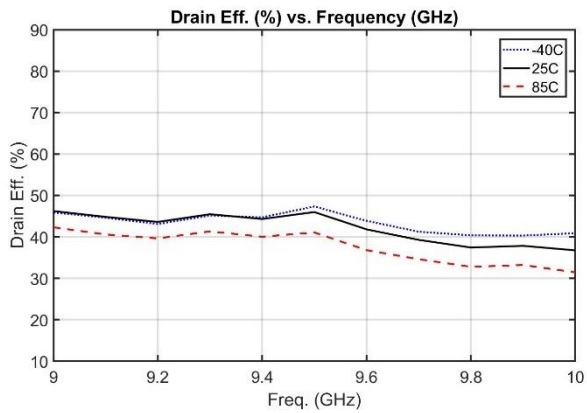
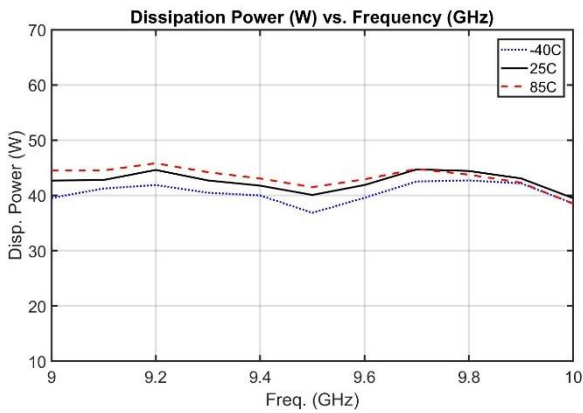
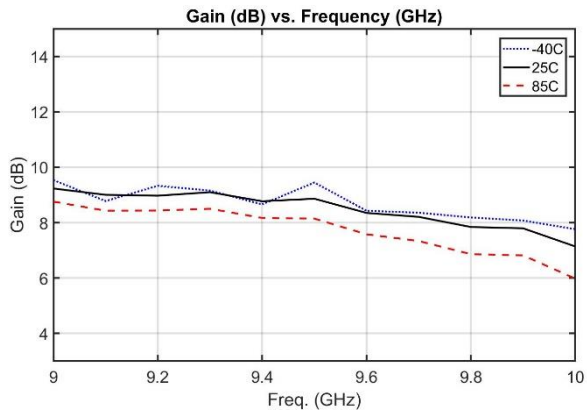
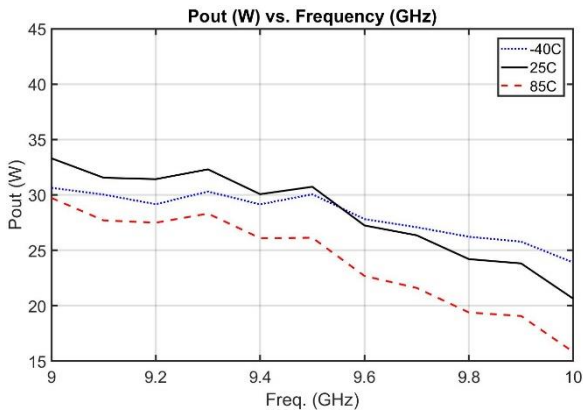

Power Performance Over Temperatures and V_D Of 9 – 10 GHz EVB^{1, 2}

Notes:

1. At QPD9300 Package.
2. EVB Input Power = 37 dBm, $I_{DQ} = 240$ mA, 100 μ S PW, 10% DC

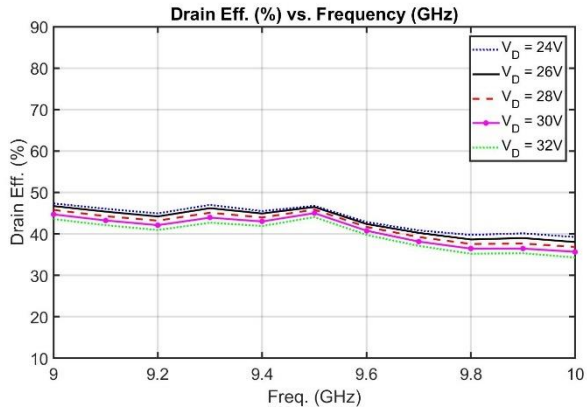
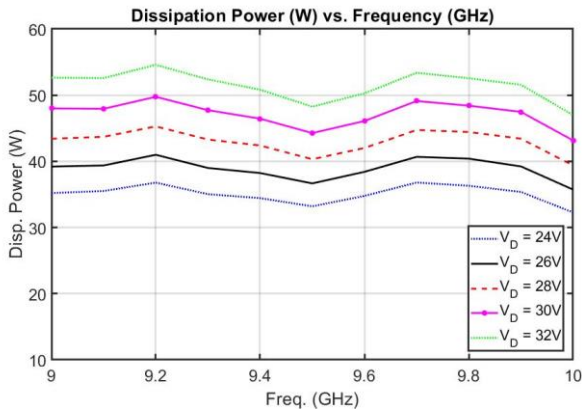
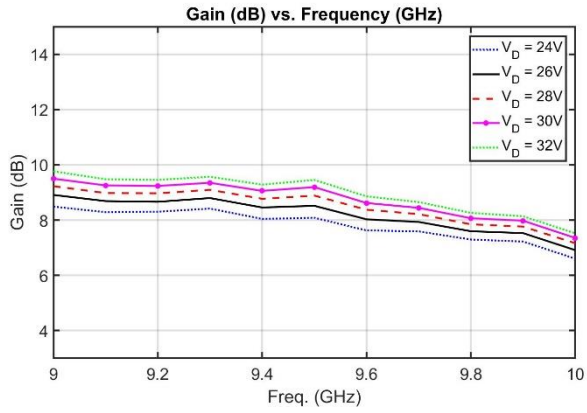
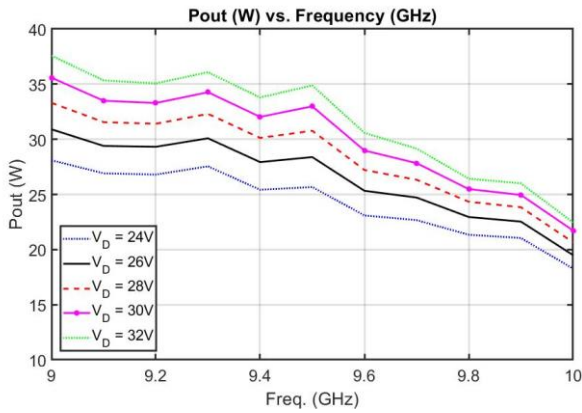

Pin Configuration and Description, and Package Marking¹

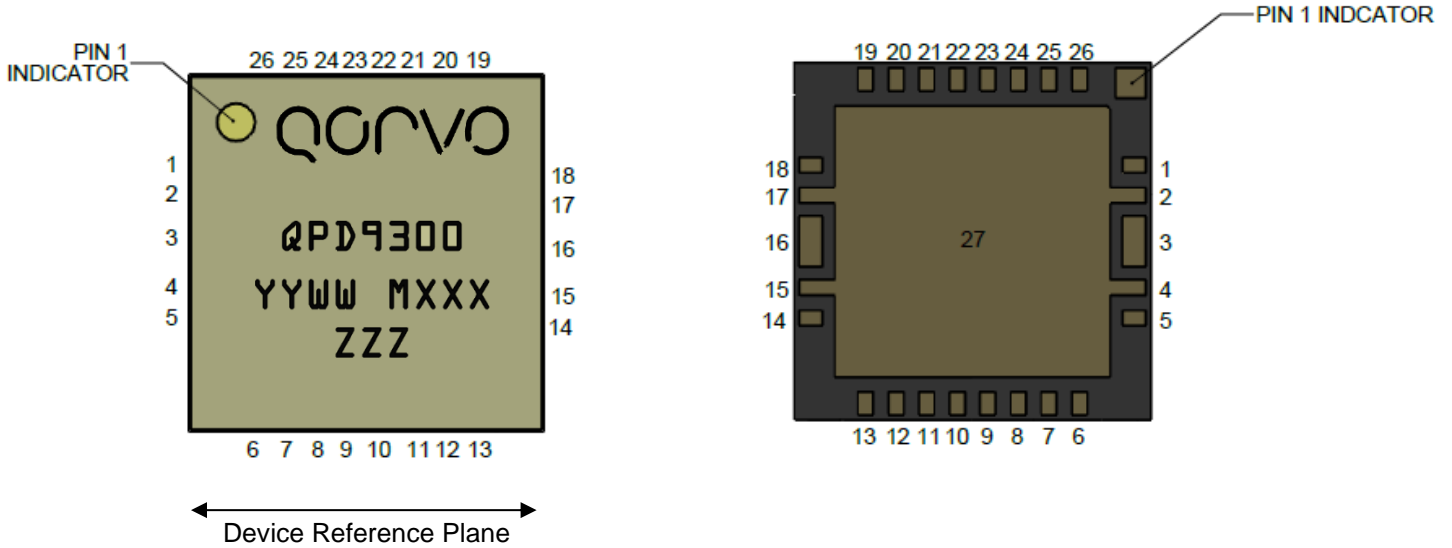

Notes:

- The QPD9300 will be marked with the “QPD9300” designator and a lot code marked below the part designator. The “YY” represents the last two digits of the calendar year the part was manufactured, the “WW” is the work week of the assembly lot

Pin Description

Pin	Symbol	Description
3	V_G / RF IN	Gate voltage / RF Input
16	V_D / RF OUT	Drain voltage / RF Output
1, 5, 6, 7, 8, 9, 10, 11, 12, 13, 14, 18, 19, 20, 21, 22, 23, 24, 25, 26	N/C	No Connection ¹
2, 4, 15, 17, 27	GND	Package Base

¹ To be grounded in board layout.

start, the “MXXX” is the batch ID, ZZZ is unique for all parts within one assembly lot.

Package Dimensions^{1, 2, 3, 4, 5}

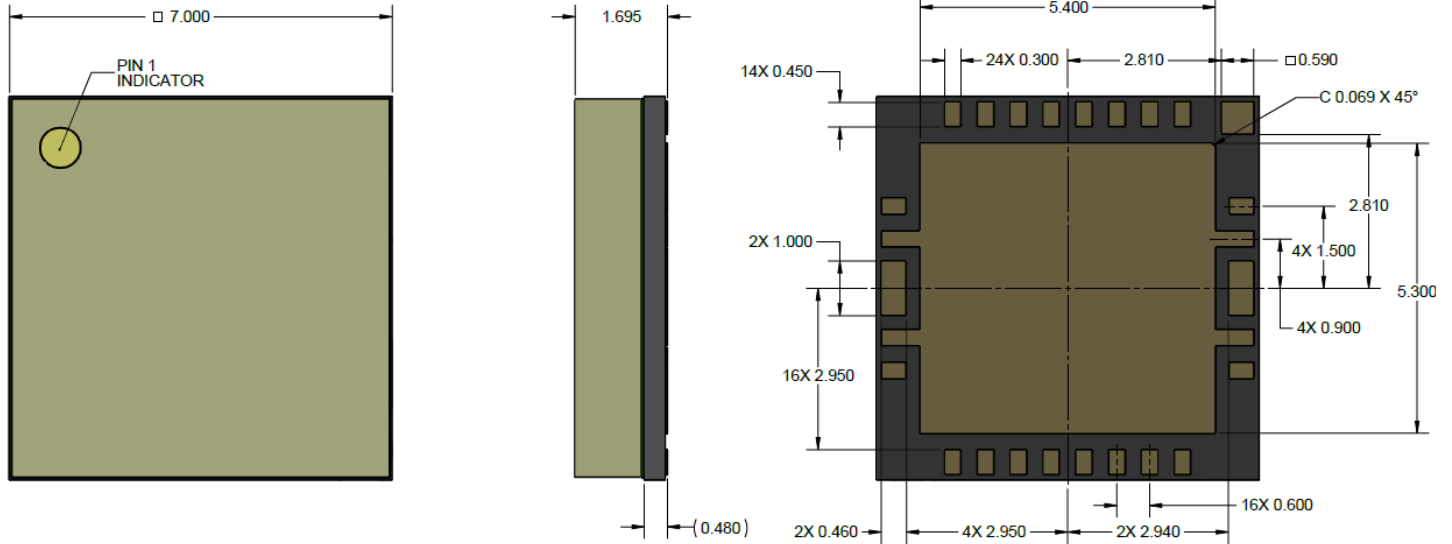

Notes:

1. Dimension unit is mm.
2. Unless otherwise noted, dimension tolerance is ± 0.127 mm.
3. Material:
 Package Base: Laminate
 Package Lid: Laminate
4. Package exposed metallization is gold plated.
5. Part is epoxy sealed.

Schematic – 9 – 10 GHz EVB

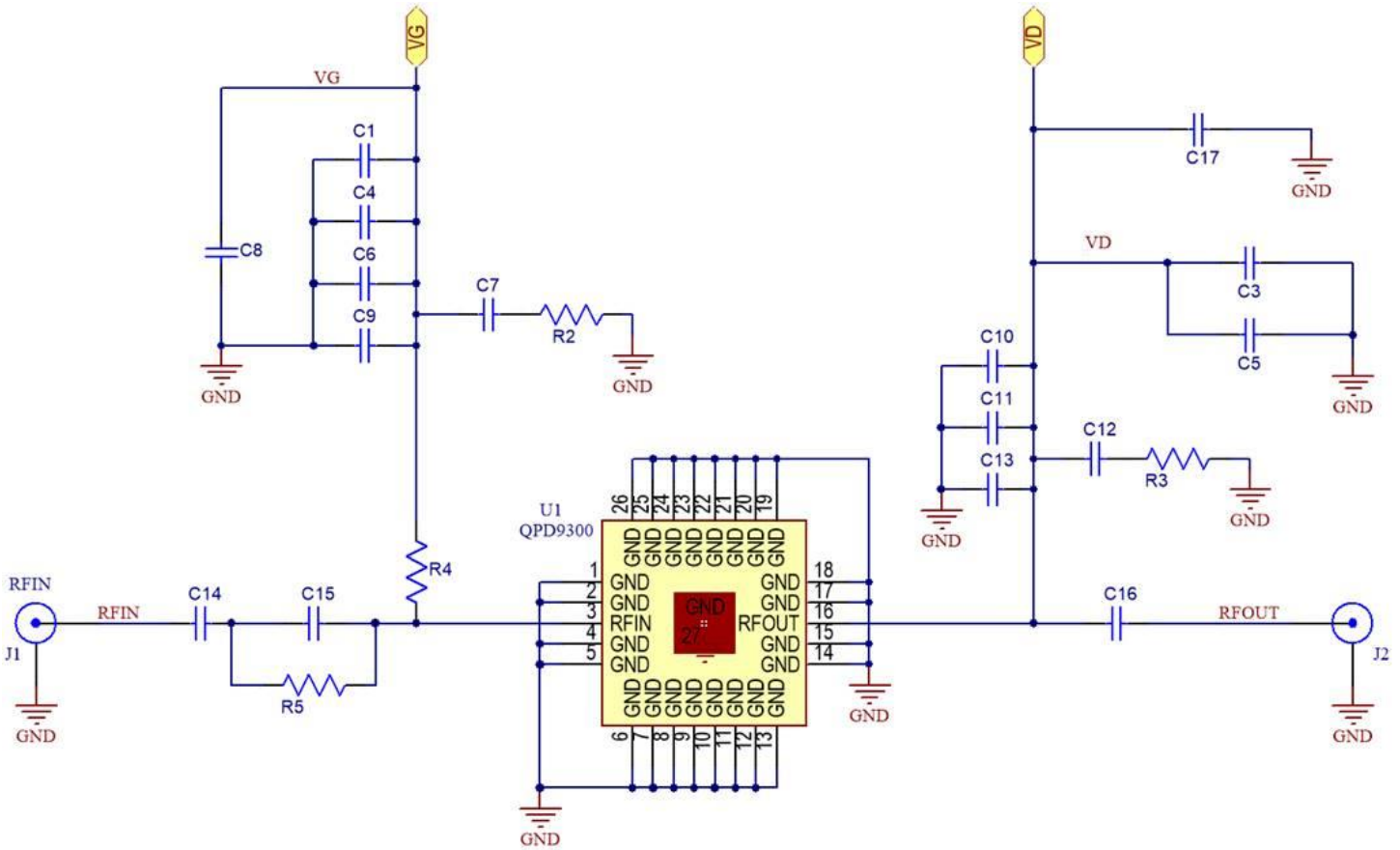

Bias-up Procedure

1. Set V_G to -4 V
2. Set I_D current limit to 250 mA
3. Apply 28 V V_D
4. Slowly adjust V_G until I_D is set to 240 mA
5. Set I_D current limit to 0.6 A
6. Apply RF

Bias-down Procedure

1. Turn off RF signal
2. Turn off V_D
3. Wait 2 seconds to allow drain capacitor to discharge
4. Turn off V_G

Layout - 9 – 10 GHz EVB¹

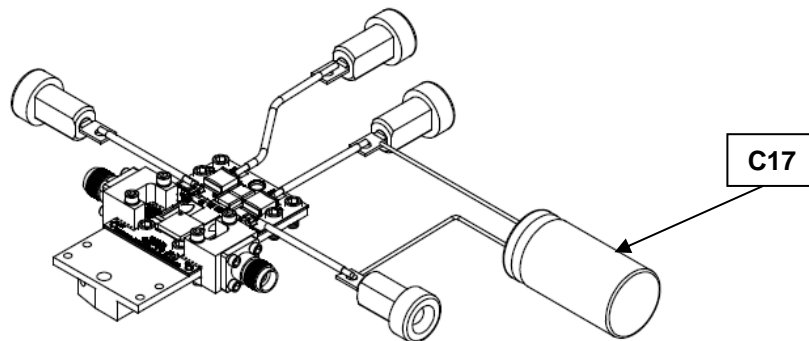
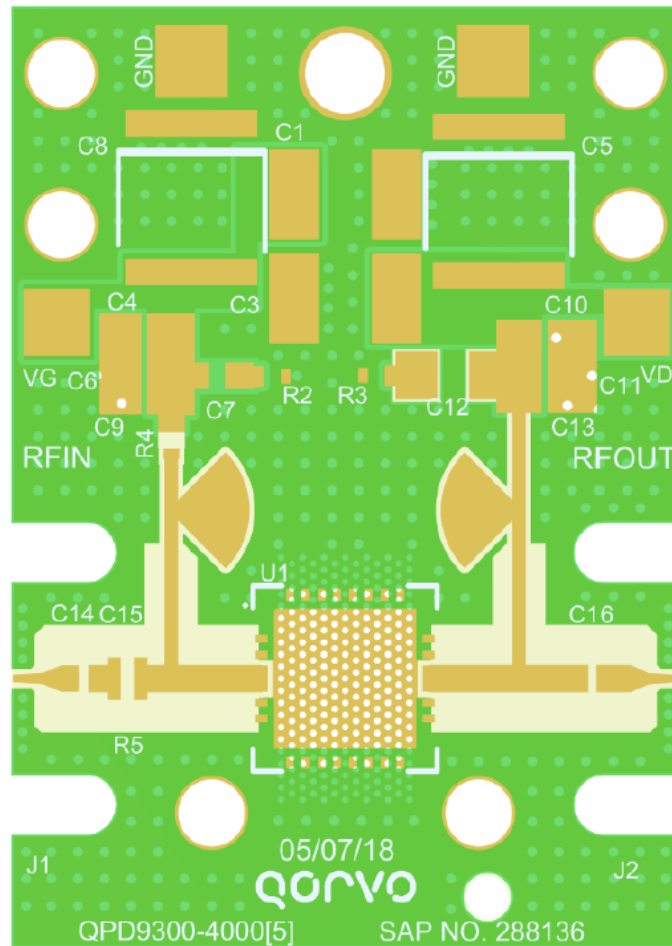

Notes:

1. PCB Material: RO4350B, 20 mil thickness, 1 oz copper cladding



QPD9300

30 W, 28 V, 9.2 – 9.7 GHz, GaN RF IMFET

Bill Of material – 9 – 10 GHz EVB

Ref Des	Value	Qty	Manufacturer	Part Number
C4, C10	10000 pF, 100 V	2	AVX	08051C103KAZ2A
C1, C3	1 uF, 100 V	2	AVX	18121C105KAT2A
C6, C11	100 pF, 250 V	2	AVX	UQCSVA101JAT2A\500
C9, C13	1.8 pF, 200 V	2	AVX	UQCL2A1R8BAT2A\500
C14, C15, C16	1.0 pF, 200 V	3	AVX	UQCL2A1R0BAT2A\500
C5, C8	10 uF, 100 V	2	Murata	22201C106MAT2A
C17	220 uF, 100 V	1	Nichicon	UVY2A221MHD1TO
R4	10 Ω	1	Panasonic	ERJ-2GEJ100X
R5	1 k Ω	1	Panasonic	ERJ-PA2J102X
J1, J2	Connector	2	Southwest Microwave	1092-01A-5
C7, C12, R2, R3	Do Not Place			

Recommended Solder Temperature Profile

