



QPF4506B

Wi-Fi Front End Module

Product Overview

The Qorvo® QPF4506B is an integrated front end module (FEM) designed for Wi-Fi 6 systems. The compact form factor and integrated matching minimizes layout area in the application.

Performance is focused on optimizing the PA for a 5 V supply voltage that conserves power consumption while maintaining the highest linear output power and leading edge throughput. Receive path matches the optimal technologies to maximize Rx sensitivity through noise figure performance that is consistent over a wider variety of conditions.

The receive path has integrated die level filtering for 2nd and 3rd harmonics as well as 2.4 GHz rejection for DBDC operation are included.

Another key feature is the integration of a DC power detector that allows power control down to low powers and enables the possibility to calibrate against a constant slope to reduce device calibration time in production.

The QPF4506B integrates a 5 GHz power amplifier (PA), regulator, single-pole two throw switch (SP2T), and a bypassable low noise amplifier (LNA).



16 Pad 3x3mm Laminate Package

Key Features

- 5150 – 5925MHz
- P_{OUT} = +15 dBm MCS11 HE160 -43 dB Dynamic EVM
- P_{OUT} = +21 dBm MCS9 VHT80 -35 dB Dynamic EVM
- P_{OUT} = +23 dBm MCS7 HT20/40 -30 dB Dynamic EVM
- P_{OUT} = +25 dBm MCS0 HT20 Spectral Mask Compliance
- Optimized for +5 V Operation
- 30 dB Tx Gain
- 1.7 dB Noise Figure
- 13.5 dB Rx Gain & 6 dB Bypass Loss
- 28 dB 2.4 GHz Rejection on Rx Path
- Integrated Logarithmic DC Power Detector

Functional Block Diagram

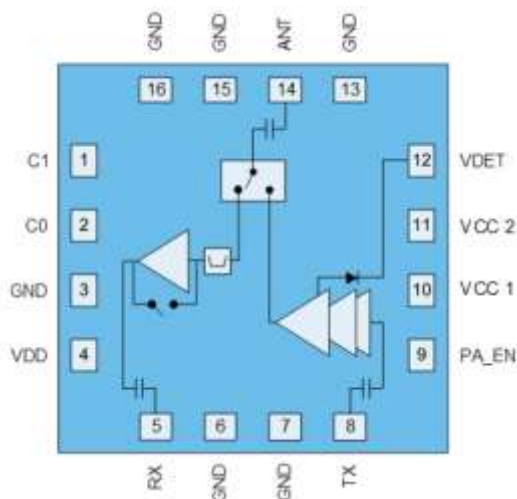

Top View

Applications

- Access Points
- Wireless Routers
- Residential Gateways
- Customer Premise Equipment
- Internet of Things

Ordering Information

Part Number	Description
QPF4506BSB	Sample bag with 5 pieces
QPF4506BSQ	Sample bag with 25 pieces
QPF4506BSR	7" reel with 100 pieces
QPF4506BTR13-5K	13" reel with 5000 pieces
QPF4506BEVB-01	Assembled Evaluation Board

Absolute Maximum Ratings

Parameter	Conditions	Rating
DC Supply Voltage		-0.5 to +6 V
Control Voltage	PA_EN, C0 & C1	-0.5 to +6 V
Storage Temperature		-40 to 150 °C
Junction Temperature	MTTF > 1.5x10 ⁶ hours	160 °C
	MTTF > 1.0x10 ⁶ hours	170 °C
RF Input Power at TX_IN	Into 50 Ω Load for 802.11a-ax (No Damage), Transmit Mode	+10 dBm
RF Input Power at ANT	(No Damage), Receive LNA On Mode	+15 dBm
RF Input Power at ANT	(No Damage), Receive Bypass Mode	+28 dBm

Exceeding any one or a combination of the Absolute Maximum Rating conditions may cause permanent damage to the device. Extended application of Absolute Maximum Rating conditions to the device may reduce device reliability. This is an InGaP device designed for high duty cycle applications with T_J>30 °C over ambient.

Recommended Operating Conditions

Parameter	Min.	Typ.	Max.	Units
Operating Frequency	5150		5850	MHz
Extended Operating Frequency	4900		5925	MHz
Device Voltage (V _{CC} & V _{DD})	+4.75	+5	+5.25	V
Extended Device Voltage (V _{CC} & V _{DD})	+3.15		+5.5	V
Control Voltage – High	+1.6		V _{CC}	V
Control Voltage - Low	0		+0.4	V
T _{OPERATING} *	-40		+85	°C

Electrical specifications are measured at specified test conditions. Extended Parameters have degraded performance but operational. Specifications are not guaranteed over all recommended operating conditions. * T_{OPERATING} is temperature at package ground.

Electrical Specifications

Parameter	Conditions	Min.	Typ.	Max.	Units
TRANSMIT (TX-ANT) MODE					
Unless otherwise noted: V_{CC/DD}=5V, T=+25°C, PA_EN=High, C0 =Low, C1=High					
Wi-Fi 6 HE160 ⁽¹⁾ Output Power	MCS11 1024QAM (11ax)		15		dBm
Dynamic EVM				-43	dB
Wi-Fi 6 HE160 Output Power	MCS11 1024QAM (11ax)	16	18		dBm
					-40
Wi-Fi 5 VHT80 Output Power	MCS9 256QAM (11ac)	19	21		dBm
Dynamic EVM					-35
Wi-Fi 4 HT20/40 Output Power	MCS7 64QAM (11n)	21.5	23		dBm
Dynamic EVM					-30
Margin to VHT80 Spectral Mask	P _{OUT} = +24 dBm, 11ac MCS0	0	3		dBc
Margin to HT20 Spectral Mask	P _{OUT} = +25 dBm, 11n MCS0	0	3		dBc
Gain		28	30		dB
Gain Flatness	Across any 160 MHz Channel	-0.85		+0.85	dB
Out of Band Gain	f = 3300-3800 MHz		-10	-4.5	dB
TX Port Return Loss		7.5	15		dB

Parameter	Conditions	Min.	Typ.	Max.	Units
ANT Port Return Loss			15		dB
Quiescent Current	RF Off		117		mA
Operating Current	P _{OUT} = +15 dBm		150		mA
	P _{OUT} = +24 dBm		270	300	mA
2 nd Harmonics	P _{OUT} = +24 dBm 802.11a 6 Mbps		-35	-30	dBm/MHz
3 rd Harmonics	P _{OUT} = +24 dBm 802.11a 6 Mbps		-50	-45	dBm/MHz
ANT-RX Isolation			45		dB
DC Power Detect Voltage	RF Off		0.25		V
	P _{OUT} = +10 dBm		0.4		V
	P _{OUT} = +25 dBm		0.84		V
DC Power Detect Slope	P _{OUT} = +10 to +25 dBm		29.3		mV/dB
RECEIVE (ANT-RX) LNA ON MODE	Unless otherwise noted: V_{CC/DD}=5V, T=+25°C, PA_EN=Low, C0=High, C1=Low				
Gain		12	13.5		dB
Gain Flatness Across any 160 MHz Channel		-0.5		+0.5	dB
Out of Band Gain	f = 2400-2500 MHz		-28		dB
Noise Figure			1.7	2	dB
RX Port Return Loss		6	12		dB
ANT Port Return Loss		6	12		dB
Input P _{1dB}			+6		dBm
Input IP3	2-tone CW, 1 MHz spacing		+13		dBm
Rx Operating Current			35	45	mA
RECEIVE (ANT-RX) BYPASS MODE	Unless otherwise noted: V_{CC/DD}=5V, T=+25°C, PA_EN=Low, C0=High, C1=High,				
Bypass Loss		5	6.5		dB
Loss Flatness Across any 160 MHz Channel		-0.25		+0.25	dB
Out of Band Gain	f = 2400-2500 MHz		-30		dB
RX Port Return Loss		8	12		dB
ANT Port Return Loss		5	6		dB
Input P _{1dB}			+23		dBm
Input IP3			+36		dBm
GENERAL SPECIFICATIONS	Unless otherwise noted: V_{CC/DD}=5V, T=+25°C, Switching Time Power Accuracy +/-1dB				
Control Current - High				150	µA
Control Current - Low			100		nA
TX Output P _{1dB}	CW		29		dBm
Switching Time	Transmit to LNA On or Bypass Mode			400	nS
	LNA On to Bypass Mode			200	nS
	Bypass to LNA On Mode			200	nS
	LNA On or Bypass to Transmit Mode			400	nS
PA Stability - Output VSWR	CW No Spurious above -41.25 dBm/MHz		10:1		
Output Power Range		0		25	dBm
Thermal Resistance, θ _{jc}	Junction to case, Pout =25dBm,4ms, MCS11, 50% DC		40		°C/W

Logic Truth Table

Mode	State	PA_EN	C0	C1
All Off	1	Low	Low	Low
Transmit	2	High	Low	High
LNA On	3	Low	High	Low
Bypass LNA	4	Low	High	High
Reserved	5	Low	Low	High
Reserved	6	High	Low	Low

Notes:

1. Normalized to -50dB source.

Evaluation Board Schematic

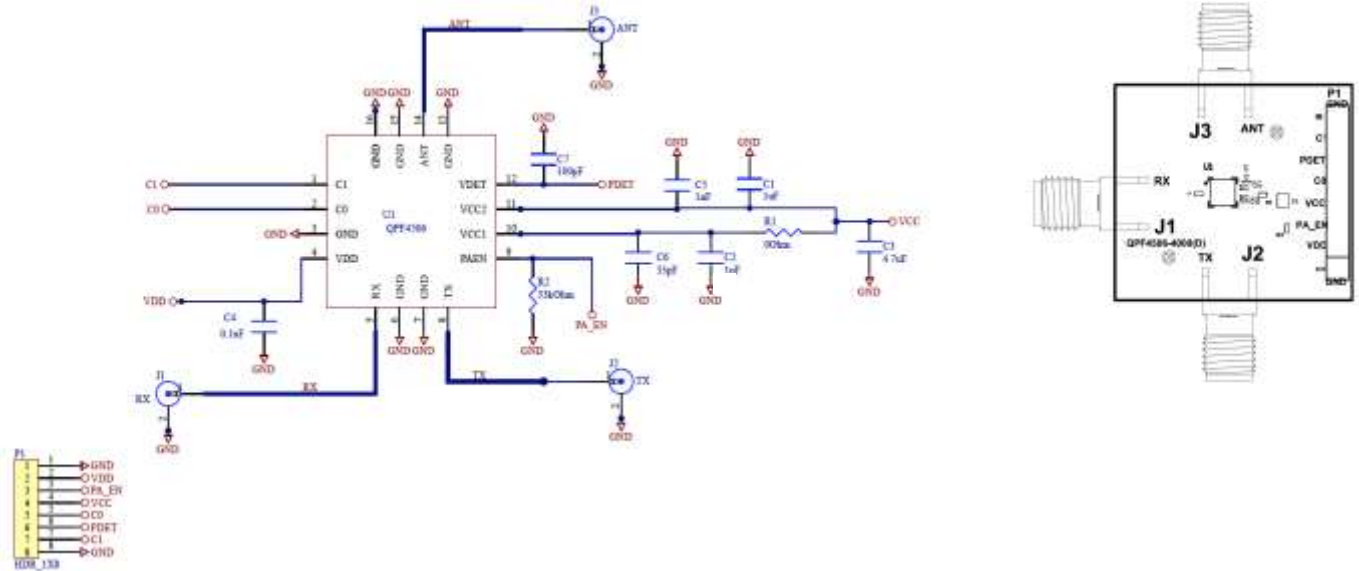

Ref. Des.	Value	Description	Manuf.	Part number
-	-	Printed Circuit Board		
U1	-	5GHz Wi-Fi Front End Module	Qorvo	QPF4506B
C3	4.7µF	CAP, 10%, 16V, X7R, 0805	Murata	GRM21BR71C475KA73L
C1,C2	1µF	CAP, 20%, 6.3V, X5R, 0201	Murata	GRM033R60J105MEA2D
C4	0.1µF	CAP, 10%, 16V, X5R, 0201	Murata	GRM155R71C104KA88D
C5	1,000pF	CAP, 10%, 50V, X7R, 0201		
C7	100pF	CAP, 5%, 25V, C0G, 0201		
C6	33pF	CAP, 5%, 25V, C0G, 0201		
R1	0Ω	Resistor, Chip, 5%, 1/10W, 0402	Kamaya	RMC1/16SJPTH
R2	33,000Ω	Resistor, Chip, 5%, 1/16W, 0402	Kamaya	RMC1/16S-333JTH

Pin Configuration and Description

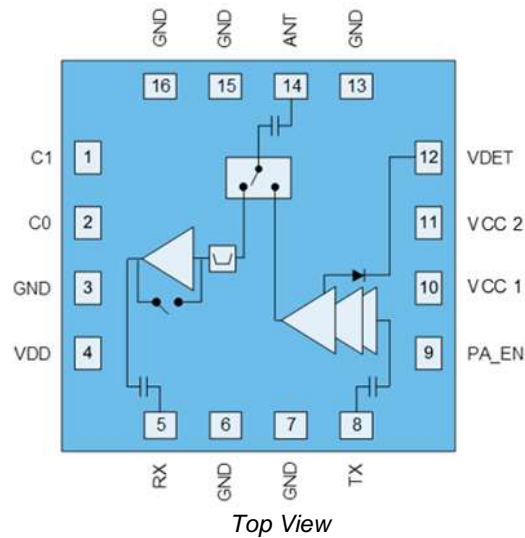

Pin Number	Label	Description
1	C1	Control Pin
2	C0	Control Pin
3	GND	Ground connection.
4	VDD	LNA Supply Voltage
5	RX	RF output from the low noise amplifier. Internally matched to 50 Ω and DC blocked.
6	GND	Ground connection.
7	GND	Ground connection.
8	TX	RF input. Internally matched to 50 Ω and DC blocked.
9	PA_EN	Control Pin
10	VCC1	1 st stage supply voltage
11	VCC 2	2 nd stage supply voltage
12	VDET	DC power detector. Provides an output voltage proportional to the RF output power level
13	GND	Ground connection.
14	ANT	RF bi-directional antenna port. Internally matched to 50 Ω and DC blocked.
15	GND	Ground connection.
16	GND	Ground connection.
Pkg Base	GND	Ground connection.

Mechanical Information

Dimensions and PCB Mounting Pattern

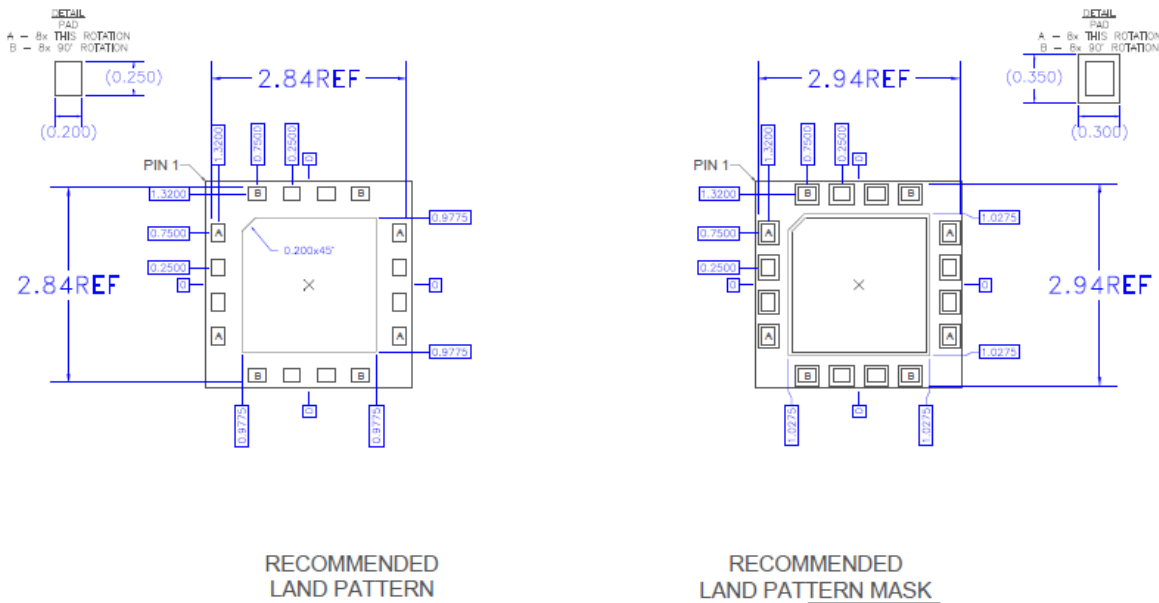
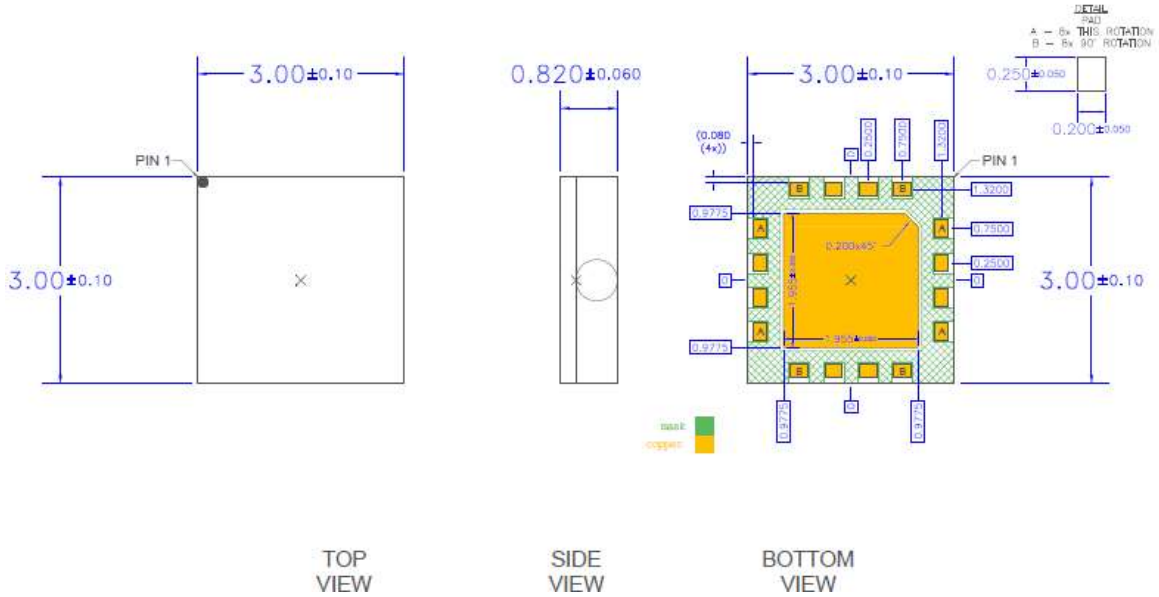

- Notes:
2. All dimensions are in millimeters. Angles are in degrees.
 3. Dimension and tolerance formats conform to ASME Y14.4M-1994.
 4. The terminal #1 identifier and terminal numbering conform to JESD 95-1 SPP-012.