

Product Overview

The Qorvo® QPF8248 is an integrated front end module (FEM) designed for Wi-Fi 5 (802.11ac) systems. The compact form factor and integrated matching minimizes layout area in the application.

Performance is focused on a balance of efficiency versus linear power that increases the range and throughput of connections. Control lines are reduced to a two pin scheme.

Integrated die level filtering for 2nd and 3rd harmonics as well as 5GHz rejection for DBDC operation are included.

The QPF8248 integrates a 2.4 GHz power amplifier (PA), single pole three throw switch (SP3T) and low noise amplifier (LNA) into a single device.

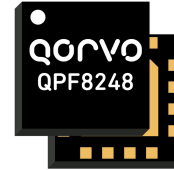

16 Pad 2.3x2.3 mm Laminate Package

Functional Block Diagram

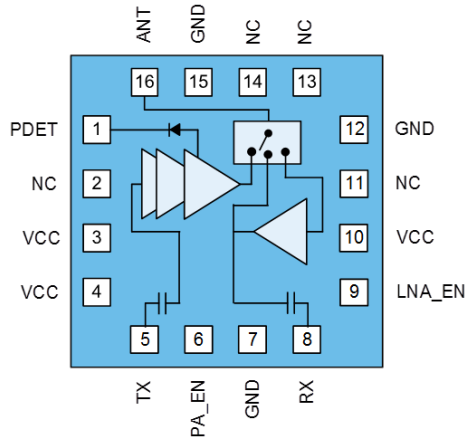

Top View

Key Features

- 2412 – 2484 MHz
- $P_{OUT} = +17.5$ dBm MCS8/9 VHT40 -35 dB Dynamic EVM
- $P_{OUT} = +19$ dBm MCS7 HT20/40 -30 dB Dynamic EVM
- $P_{OUT} = +20$ dBm 802.11g -28 dB Dynamic EVM
- $P_{OUT} = +23$ dBm 802.11b Spectral Mask Compliance
- Optimized for +3.3 V Operation
- Low Power Mode Enabled
- 28.5 dB Tx Gain
- 2.5 dB Noise Figure
- 13.5 dB Rx Gain & 1.4 dB Bypass Loss
- Integrated DC Power Detector

Applications

- Access Points
- Wireless Routers
- Residential Gateways
- Set-Top Boxes
- Customer Premise Equipment
- Internet of Things

Ordering Information

Part Number	Description
QPF8248SB	Sample bag with 5 pieces
QPF8248SQ	Sample bag with 25 pieces
QPF8248SR	7" reel with 100 pieces
QPF8248TR13	13" reel with 10,000 pieces
QPF8248PCK410	Assembled Evaluation Board + 5 pcs

Absolute Maximum Ratings

Parameter	Conditions	Rating
DC Supply Voltage		-0.5 to +6 V
Control Voltage	PA_EN & PNA_EN	-0.5 to +V _{CC} V
Storage Temperature		-40 to 150 °C
Junction Temperature	MTTF > 0.7 x10 ⁶ hours MTTF > 1.0 x10 ⁶ hours	160 °C 150 °C
RF Input Power at TX_IN	Into 50 Ω Load for 802.11b/g/n/ac (No Damage), Transmit Mode	+12 dBm
RF Input Power at ANT	(No Damage), Receive LNA On Mode	+5 dBm
RF Input Power at ANT	(No Damage), Receive Bypass Mode	+25 dBm

Exceeding any one or a combination of the Absolute Maximum Rating conditions may cause permanent damage to the device. Extended application of Absolute Maximum Rating conditions to the device may reduce device reliability.

Recommended Operating Conditions

Parameter	Min.	Typ.	Max.	Units
Operating Frequency	2412		2484	MHz
Device Voltage (V _{CC} & V _{DD})	+3	+3.3	+4.2	V
Extended Device Voltage (V _{CC})	+3		+5.25	V
Control Voltage – High (PA_EN & LNA_EN)	+2.8	+2.95	V _{CC}	V
Control Voltage – Low (PA_EN & LNA_EN)	0		+0.2	V
T _{OPERATING} *	-40		+85	°C

Electrical specifications are measured at specified test conditions. Specifications are not guaranteed over all recommended operating conditions. * T_{OPERATING} is temperature at package ground.

Electrical Specifications

Parameter	Conditions	Min.	Typ.	Max.	Units
TRANSMIT (TX-ANT) HIGH POWER	Unless otherwise noted: V_{CC}=3.3V, T=+25°C, PA_EN=High, LNA_EN=Low				
Wi-Fi 5 VHT20/40 Output Power	11ac MCS8/9 256QAM	16.5	17.5		dBm
Dynamic EVM					-35
Wi-Fi 4 HT20/40 Output Power	11n MCS7 64QAM		19		dBm
Dynamic EVM				-30	dB
11g Output Power	OFDM 54Mbps	19	20		dBm
Dynamic EVM					
Margin to HT20 Spectral Mask	P _{OUT} = +21 dBm, 11n MCS0		3	0	dBc
Margin to 802.11b Spectral Mask	P _{OUT} = +23 dBm, DSSS 1 Mbps		20	10	dBc
Gain		27	28.5		dB
Gain Flatness	Across any 40 MHz Channel	-0.25		+0.25	dB
TX Port Return Loss			6		dB
ANT Port Return Loss			15		dB
Quiescent Current	RF Off		140	160	mA
Operating Current	P _{OUT} = +17.5 dBm		190	225	mA



QPF8248 Wi-Fi Front End Module

Parameter	Conditions	Min.	Typ.	Max.	Units
	P _{OUT} = +23 dBm		275	310	mA
2 nd Harmonics	P _{OUT} = +23 dBm 802.11b 1 Mbps		-25	-20	dBm/MHz
3 rd Harmonics	P _{OUT} = +23 dBm 802.11b 1 Mbps		-40	-35	dBm/MHz
ANT-RX Isolation			45		dB
DC Power Detect Voltage	RF Off		0.30		V
	P _{OUT} = +17.5 dBm		0.50		V
	P _{OUT} = +23dBm		0.68		V
TRANSMIT (ANT-RX) LOW POWER	Unless otherwise noted: V_{CC}=3.3V, T=+25°C, PA_EN=High, LNA_EN=High				
Wi-Fi 5 VHT20/40 Output Power	11ac MCS8/9 256QAM		12		dBm
Dynamic EVM				-35	dB
Gain			28		dB
Gain Flatness		-0.25		+0.25	dB
TX Port Return Loss			6		dB
ANT Port Return Loss			10		dB
Operating Current	P _{OUT} = +12 dBm		147		mA
	P _{OUT} = +17.5 dBm		175		mA
RECEIVE (ANT-RX) LNA ON MODE	Unless otherwise noted: V_{CC}=3.3V, T=+25°C, PA_EN=Low, LNA_EN=High				
Gain			13.5		dB
Gain Flatness Across any 40 MHz Channel		-0.2		+0.2	dB
Out of Band Gain	f = 5150-5925 MHz		-7.5		dB
Noise Figure			2.5	2.7	dB
RX Port Return Loss			9		dB
ANT Port Return Loss			4		dB
Input P _{1dB}			-5.5		dBm
Input IP3			+1		dBm
Rx Operating Current			9		mA
RECEIVE (ANT-RX) BYPASS MODE	Unless otherwise noted: V_{CC}=3.3V, T=+25°C, PA_EN=Low, LNA_EN=Low				
Bypass Loss			1.4		dB
Loss Flatness Across any 40 MHz Channel		-0.1		+0.1	dB
RX Port Return Loss			10		dB
ANT Port Return Loss			10		dB
Input P _{1dB}			+28		dBm
Input IP3			+40		dBm
GENERAL SPECIFICATIONS	Unless otherwise noted: V_{CC}=3.3V, T=+25°C				
FEM Leakage Current			11	20	μA
PA_EN Control Current - High			225	400	μA
LNA_EN Control Current - High			100	200	μA
TX Output P _{1dB}	CW		+27		dBm
Ramp ON/OFF Time	10<->90% Ref from Control Voltage to RF Power		200		nS
PA Stability - Output VSWR	CW No Spurious above -41.25dBm/MHz		4:1		

Parameter	Conditions	Min.	Typ.	Max.	Units
Output Power Range		0		25	dBm
Thermal Resistance, θ_{jc}	Junction to case, MCS0 P _{OUT}		45		°C/W

Logic Truth Table

Mode	PA_EN	LNA_EN
Transmit – High Power	High	Low
Transmit – Low Power	High	High
LNA On	Low	High
Bypass	Low	Low

Evaluation Board Schematic and Layout

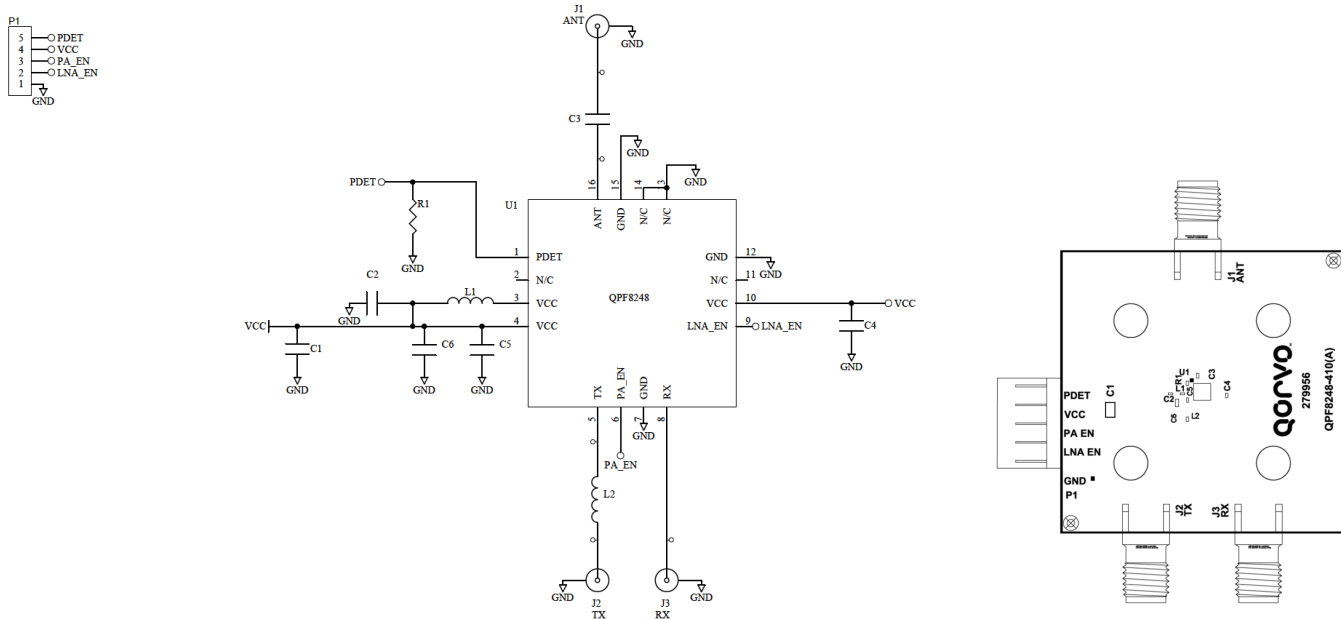

Bill of Material

Ref. Des.	Value	Description	Manuf.	Part number
-	-	Printed Circuit Board		
U1	-	2.4GHz Wi-Fi Front End Module	Qorvo	QPF8248
C6	1 μ F	Capacitor, Chip, 10%, 10V, X5R, 0402	AVX/Kyocera	0402ZD105KAT2A
C4	1000 pF	Capacitor, Chip, 10%, 25V, X7R, 0201	Samsung E-M	CL03B102KA3NNNC
C1	4.7 μ F	Capacitor, Chip, +80%/-20%, 10V, Y5V, 0805	Taiyo Yuden	CE LMK212 F475ZG-T
C3	10 pF	Capacitor, Chip, +/-0.5pF, 25V, C0G, 0201		
C2, C5	0.1 μ F	Capacitor, Chip, 10%, 6.3V, X5R, 0201		
R1	3.9K Ω	Resistor, Chip, 5%, 1/20W, 0201	Kamaya, Inc	RMC1/20-392JPA15
L2	1.8 nH	Inductor, Chip, +/- 0.3nH, M/L, 0201	Taiyo Yuden	LG HK 0603 1N8S-T
L1	3.3 nH	Inductor, Chip, +/- 0.1nH, T/F, 0201	Murata	LQP03TG3N3B02D

Pin Configuration and Description

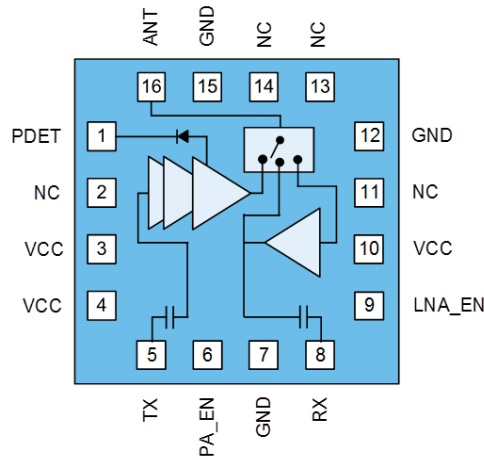

Top View

Pin Number	Label	Description
1	PDET	DC power detector. Provides an output voltage proportional to the RF output power level
2	NC	No electrical connection. It may be left floating or connected to ground.
3	VCC	1 st and 2 nd stage supply voltage
4	VCC	3 rd stage supply voltage
5	TX	RF input. Internally matched to 50 Ω and DC Blocked.
6	PA_EN	Input enable bias voltage (Regulated internally)
7	GND	Ground connection.
8	RX	RF output from the low noise amplifier or bypass. Internally matched to 50 Ω and DC blocked.
9	LNA_EN	LNA enable bias voltage
10	VCC	LNA and regulator supply voltage
11	NC	No electrical connection. It may be left floating or connected to ground.
12	GND	Ground connection.
13	NC	No electrical connection. It may be left floating or connected to ground.
14	NC	No electrical connection. It may be left floating or connected to ground.
15	GND	Ground connection.
16	ANT	RF bi-directional antenna port. Internally matched to 50 Ω . An external DC block is required.
Backside Paddle	GND	RF/DC ground. Use recommended via pattern to minimize inductance and thermal resistance. See PCB Mounting Pattern for suggested footprint.

Mechanical Information

Dimensions and PCB Mounting Pattern

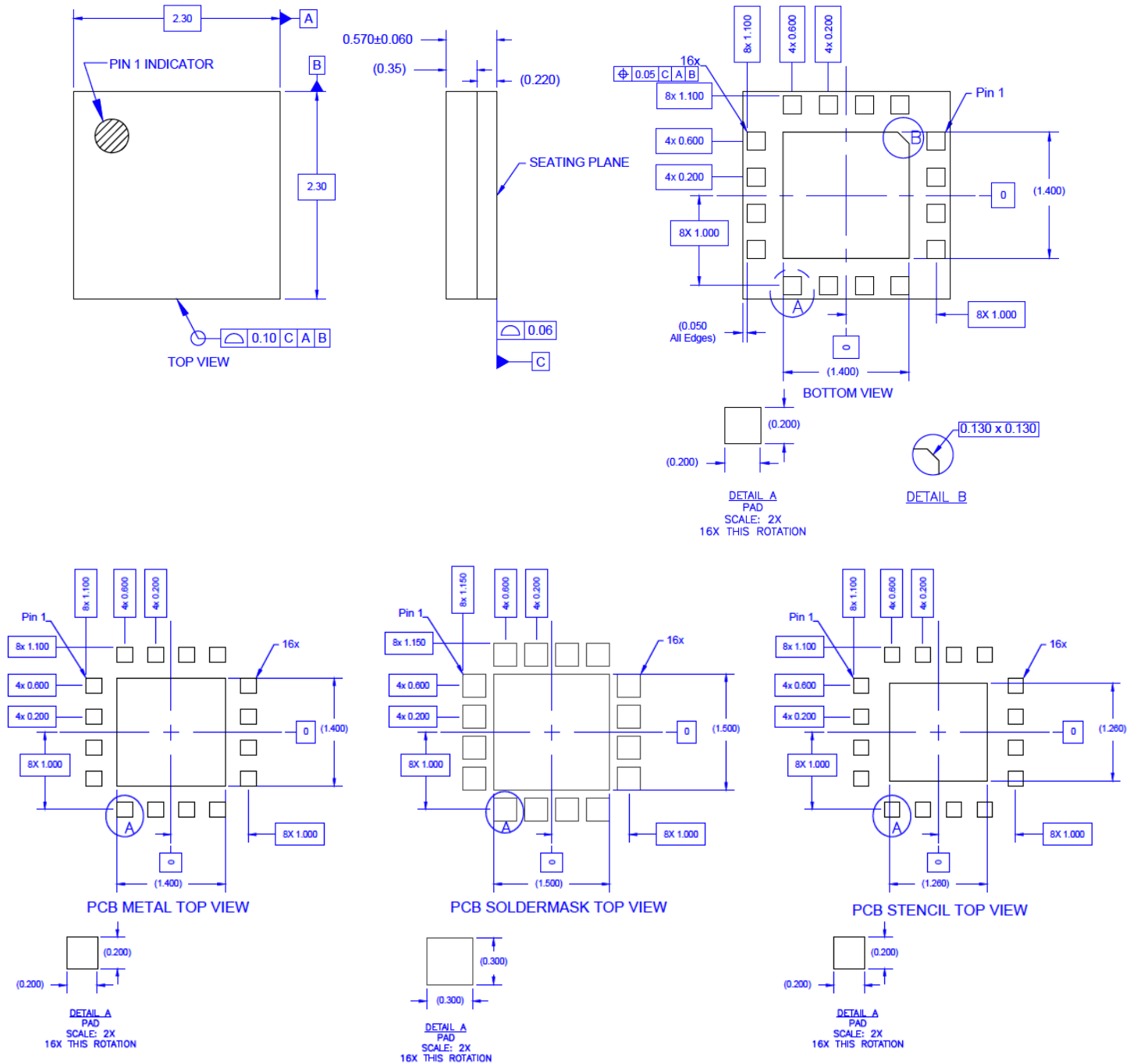

Notes:

1. All dimensions are in millimeters. Angles are in degrees.
2. Dimension and tolerance formats conform to ASME Y14.5-2009.
3. The terminal #1 identifier and terminal numbering conform to JESD 95-1 SPP-012.