

Product Overview

The QPL1815 is a high performance broadband DOCSIS 4.0 MMIC amplifier designed with GaAs pHEMT technology optimized for low noise and high linearity. A Darlington configuration is utilized for broadband performance with on-chip active bias circuit for consistent bias current and repeatable performance. The QPL1815 contains two amplifiers used in push-pull configuration for excellent second and third order linearity performance.



Package: SOIC-8

Functional Block Diagram

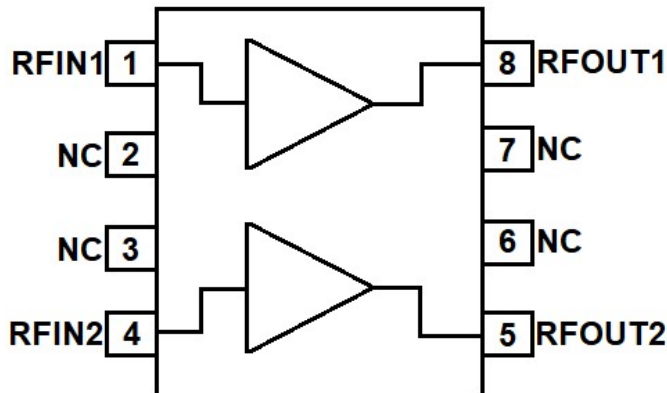

Key Features

- 7V Single Supply
- 12dB Gain @ 1800MHz
- OIP3: +40dBm
- P1dB: +24dBm
- Compact Size: 8-pin SOIC
- 50MHz to 1800MHz operation supporting DOCSIS 4.0
- pHEMT GaAs device technologies

Ordering Information

Part Number	Description
QPL1815SB	Sample bag with 5 pieces
QPL1815SR	7" Reel with 100 pieces
QPL1815TR13	13" Reel with 2500 pieces
QPL1815EVB-01	Evaluation Board

Applications

- Broadband CATV Amplifiers and Nodes
- CATV Line Driver Amplifier
- DOCSIS 4.0
- 75 Ohm Amplifiers



Absolute Maximum Ratings

Parameter	Rating	Unit
Supply Voltage (V _{DD})	9	Volts
Supply Current (I _{DD})	400	mA
Maximum RF Input Power	+10	dBm
Maximum Junction Temperature	+165	°C
Storage Temperature	-65 to +150	°C
Operating Temperature	-40 to +85	°C

Exceeding any one or a combination of the Absolute Maximum Rating conditions may cause permanent damage to the device. Extended application of Absolute Maximum Rating conditions to the device may reduce device reliability.

Electrical Specifications

Parameter	Condition ⁽¹⁾	Min	Typ	Max	Unit
Supply Voltage (V _{DD})		6.5	7	7.5	Volts
Supply Current (I _{DD})		150	215		mA
Frequency Range		50		1800	MHz
Gain			12		dB
Gain Slope			1.0		dB
Reverse Isolation			20		dB
Input Return Loss			18		dB
Output Return Loss			18		dB
Noise Figure	At 1200MHz		3.5		dB
MER ⁽²⁾ At +62dBmV Total Composite Output power	At 111MHz		44		dB
	At 1302MHz		42		dB
	At 1698MHz		42		dB
OIP2 Minus	At 50MHz		70		dBm
	At 1200MHz		65		dBm
	At 1800MHz		62		dBm
OIP3	At 50MHz		40		dBm
	At 1200MHz		40		dBm
	At 1800MHz		35		dBm
Output P1dB			24		dBm
Thermal Resistance			32		°C/W

1. Typical performance at these conditions: Temp = +25°C, VDD = +7V, 75Ω system, Full band unless otherwise noted

2. 54MHz to 1794MHz, 0dB tilt, 1 OFDM (54-246MHz) + 254 QAM (252-1794MHz) Channels. CCN Noise BW (ANSI/SCTE 17): 5.36MHz for J.83/B. Tx Data: ITU-T, Annex B, QAM256, 5.36 MSymbols/s

Typical Application Schematic 50 -1800MHz

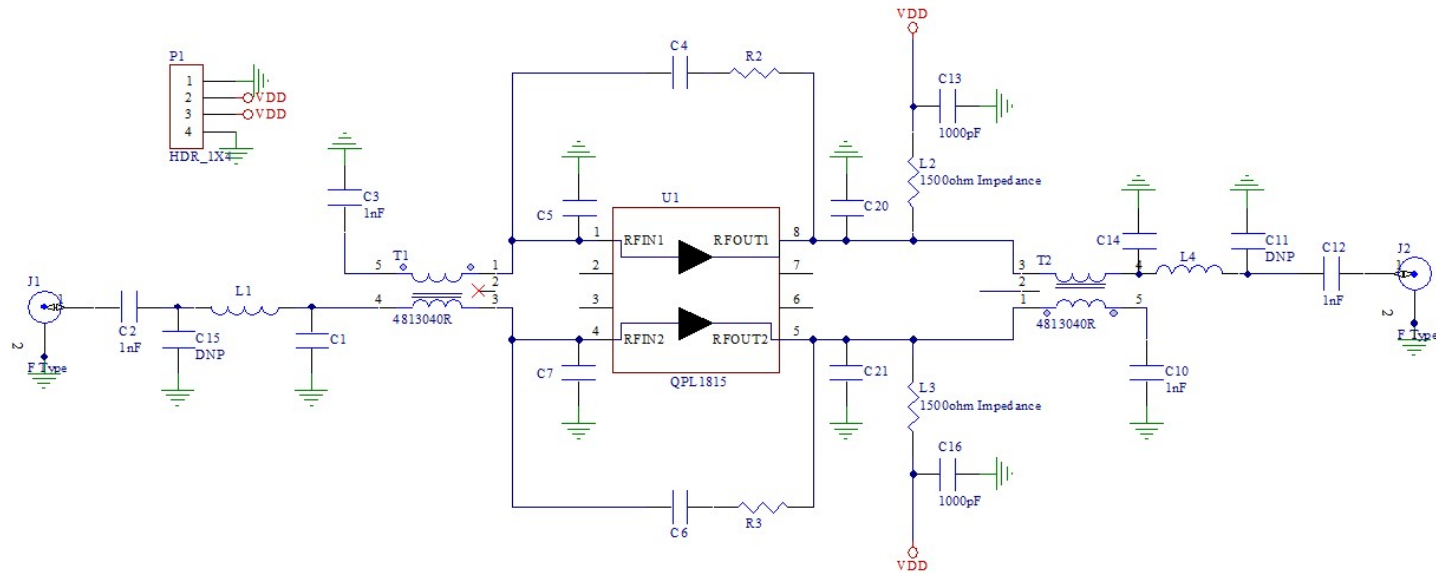

Evaluation Board Schematic 50 -1800MHz

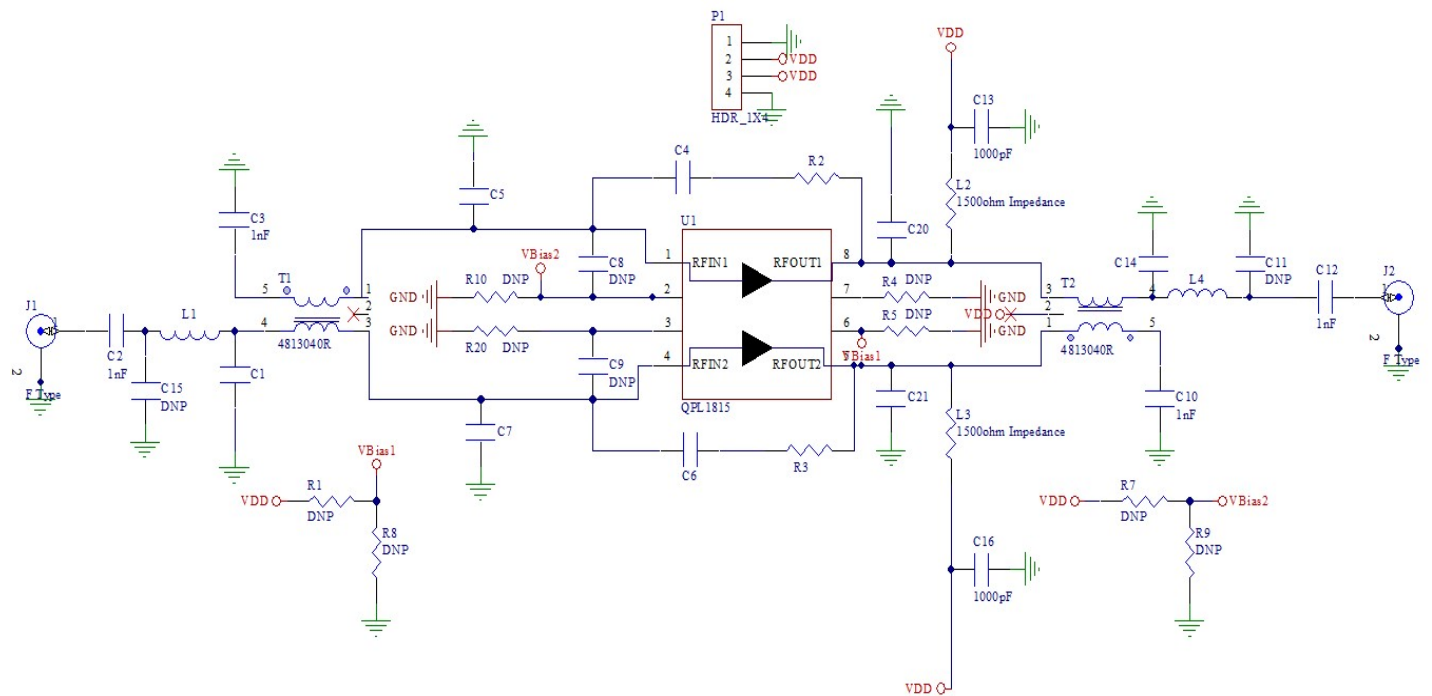

Evaluation Board Bill of Material

Ref Des	Qty	Description	Manufacturer	Manufacturer Part #
U1	1	QPL1815 50-1800MHz CATV AMP	QORVO INC	
PCB	1	PCB, QPL1815	QORVO INC	QPL1815-4000
C5, C7	2	CAP, 1pF, ±0.1pF, 50V, C0G,HIQ, 0402	MURATA ELECTRONICS SINGAPORE PTE LT	GJM1555C1H1R0BB01D
C20,C21	2	CAP, 1.2pF, +/-0.25pF, 50V, HI-Q, 0402	MURATA ELECTRONICS SINGAPORE PTE LT	GJM1555C1H1R2CB01D
C2, C3, C10, C12	4	CAP, 1000pF, 5%, 50V, C0G, 0402	MURATA ELECTRONICS SINGAPORE PTE LT	GRM1555C1H102JA01D
C4,C6	2	CAP, 100pF, 10%, 50V, STD, 0402	AVX Asia Limited	04025C101KAT2A
C13,C16	2	CAP, 1000pF, 5%, 100V, COG, 0603	Kemet	C102J1GACTU
C1,C14	2	CAP,0.5pF,+/-0.1pF,50V,HI-Q,0402	MURATA ELECTRONICS SINGAPORE PTE LT	GJM1555C1HR50BB01D
R2, R3	2	RES, 390 OHM, 5%, 1/16W, 0603	Panasonic Industrial Devices Sales	ERJ-3GEYJ391
L4	1	IND, 1.2nH, +/-0.3nH, M/L, 0402	TAIYO YUDEN (SINGAPORE) PTE LTD	LG HK10051N2S-T
L1	1	IND, 1nH, +/-0.3nH, M/L, 0402	TAIYO YUDEN (SINGAPORE) PTE LTD	LG HK 1005 1N0S-T
L2, L3	2	FER, BEAD, 1500 OHM, 500mA, 0603	MURATA ELECTRONICS SINGAPORE PTE LT	BLM18HE152SN1D
T1,T2	2	XFMR, 1:1TTL, 4.5-3000 MHz, 75 Ohm, SMD	MINNTRONIX INC	4813040R
P1	1	CONN, HDR, ST, PLRZD, 4-PIN, 0.100"	AMP	640454-4
J1, J2	2	CONN, F FEM EDGE MOUNT, 75 OHMS, 0.068"	Millimeter Wave Technologies, LLC	MW-846-C-DD-75
R1,R4,R5,R7,R8,R9, R10,R20	8	NOT POPULATED ITEM-1		DUMMY PART
C8,C9,C11,C15	4	NOT POPULATED ITEM-2		DUMMY PART

Evaluation Board Layout 50 -1800MHz

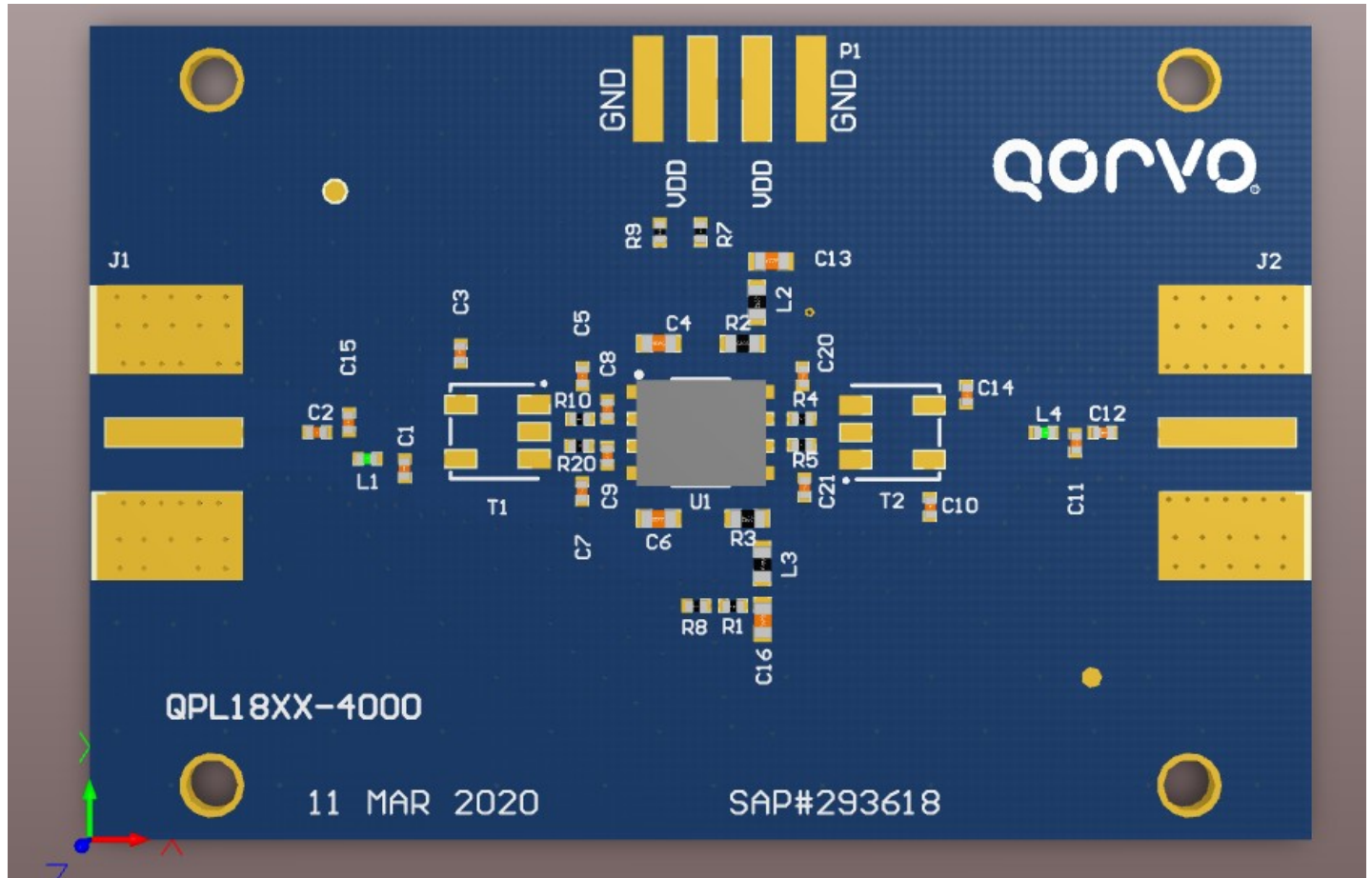

Evaluation Board PCB Material and Stack-up

2 Layer FR4 Board, 2.25inches X 1.5inches

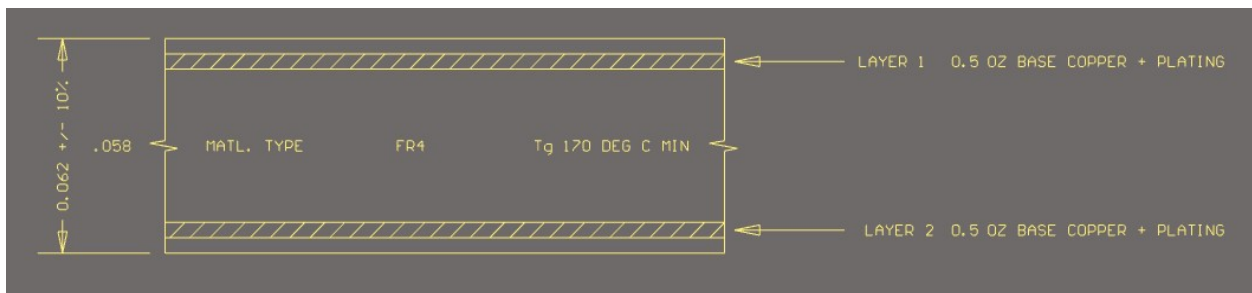

Performance Data

Typical performance conditions: Temp = +25°C, VDD = +7V, 75Ω system, Full band unless otherwise noted

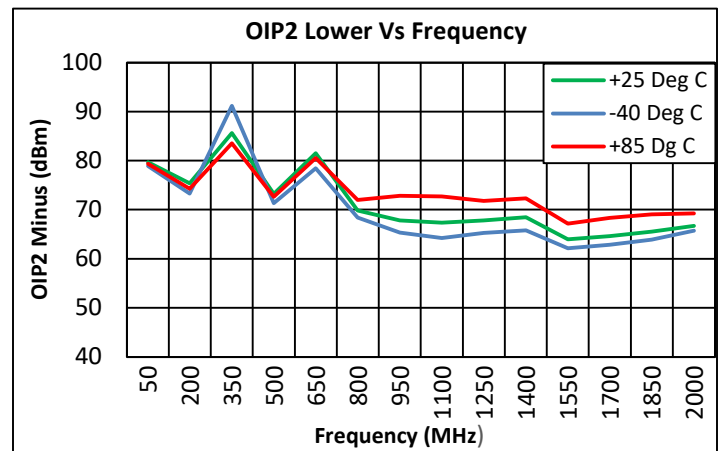
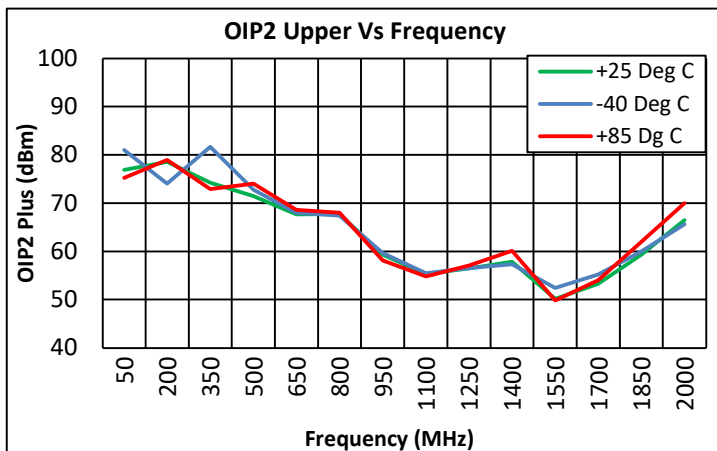
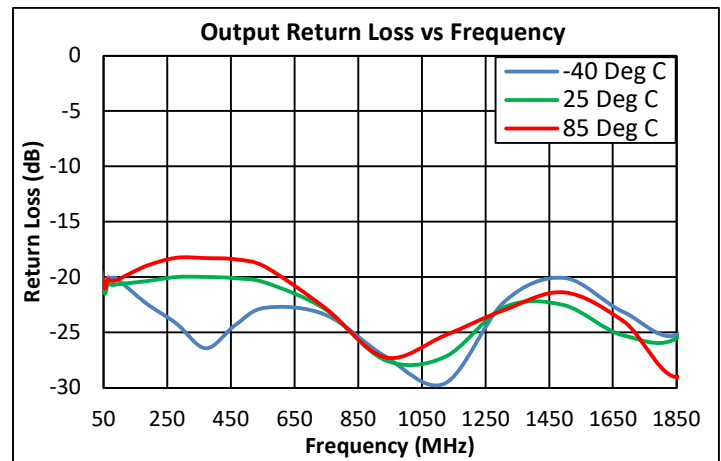
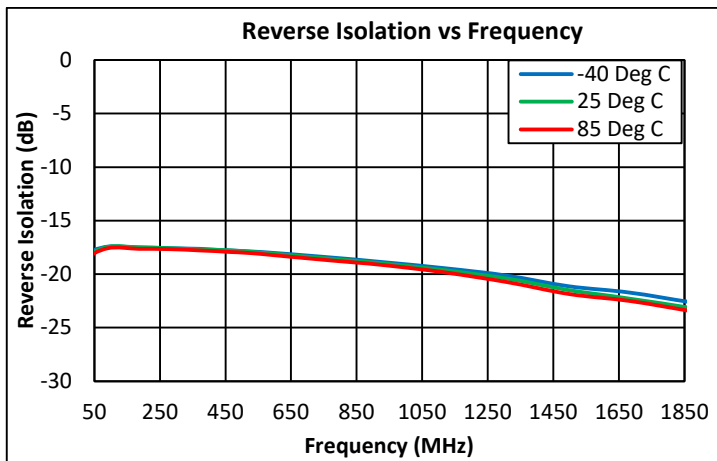
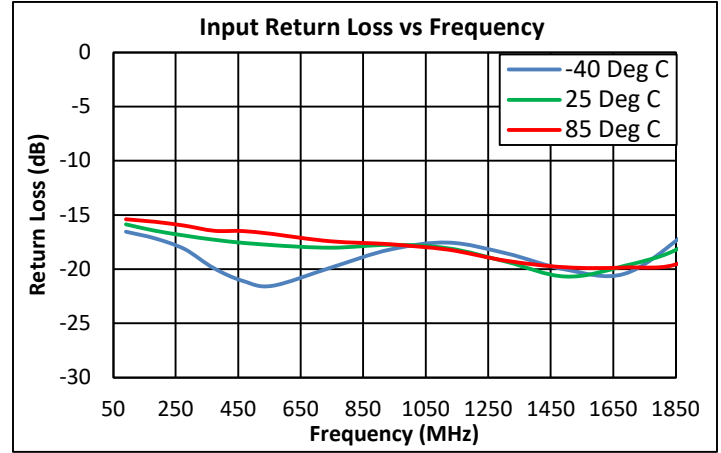
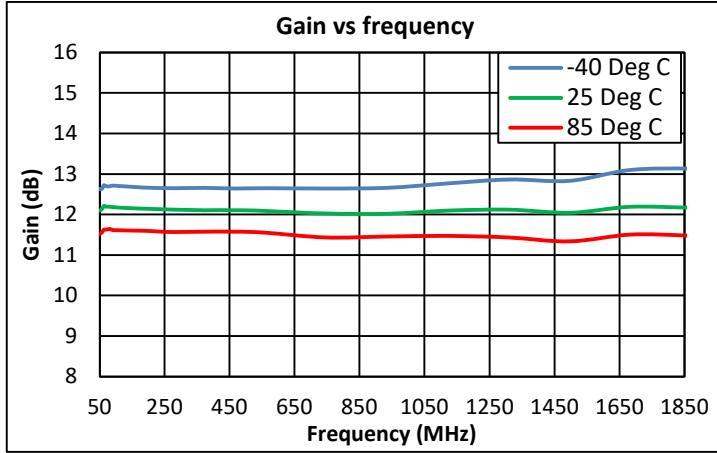

Performance Data

Typical performance conditions: Temp = +25°C, VDD = +7V, 75Ω system, Full band unless otherwise noted

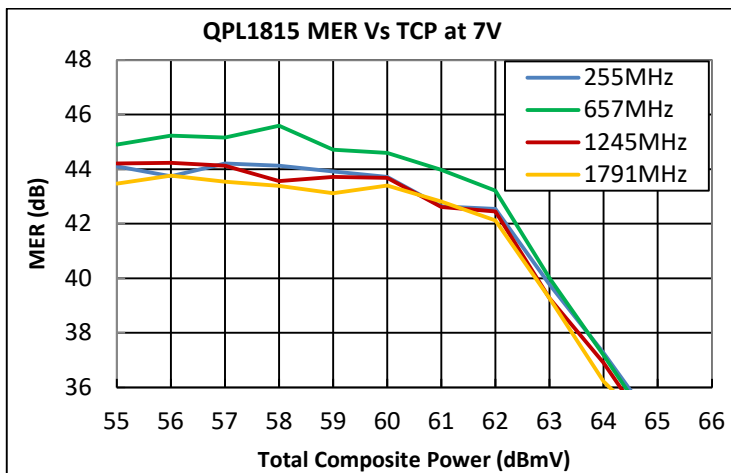
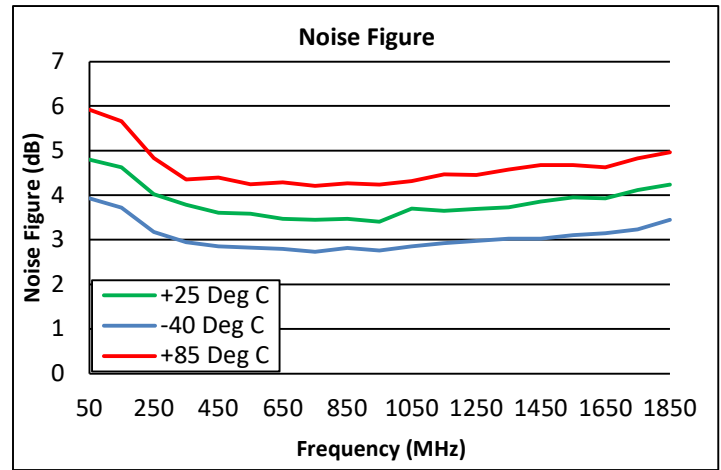
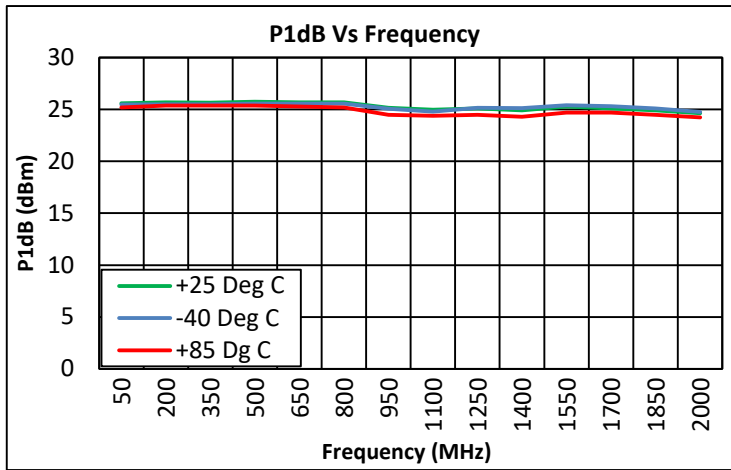
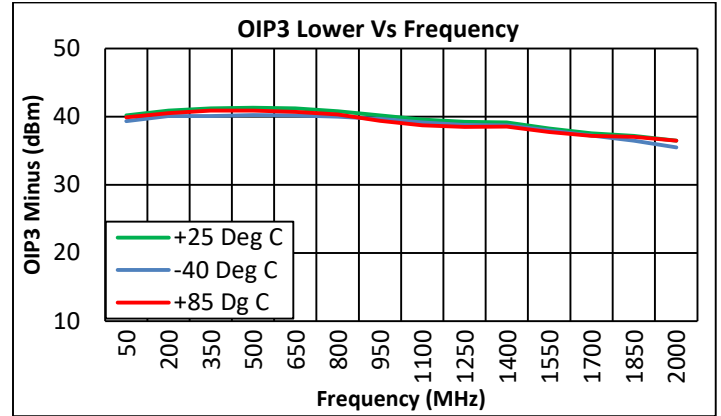
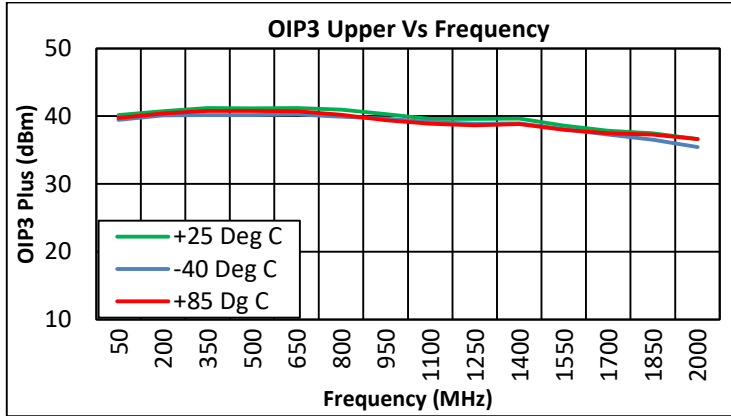

1. 54MHz to 1794MHz, 0dB tilt, 1 OFDM (54-246MHz) + 254 QAM (252-1794MHz) Channels CCN Noise BW (ANSI/SCTE 17) 5.36MHz for J.83/B. Tx Data: ITU-T, Annex B, QAM256, 5.36 MSymbols/s

Package Marking

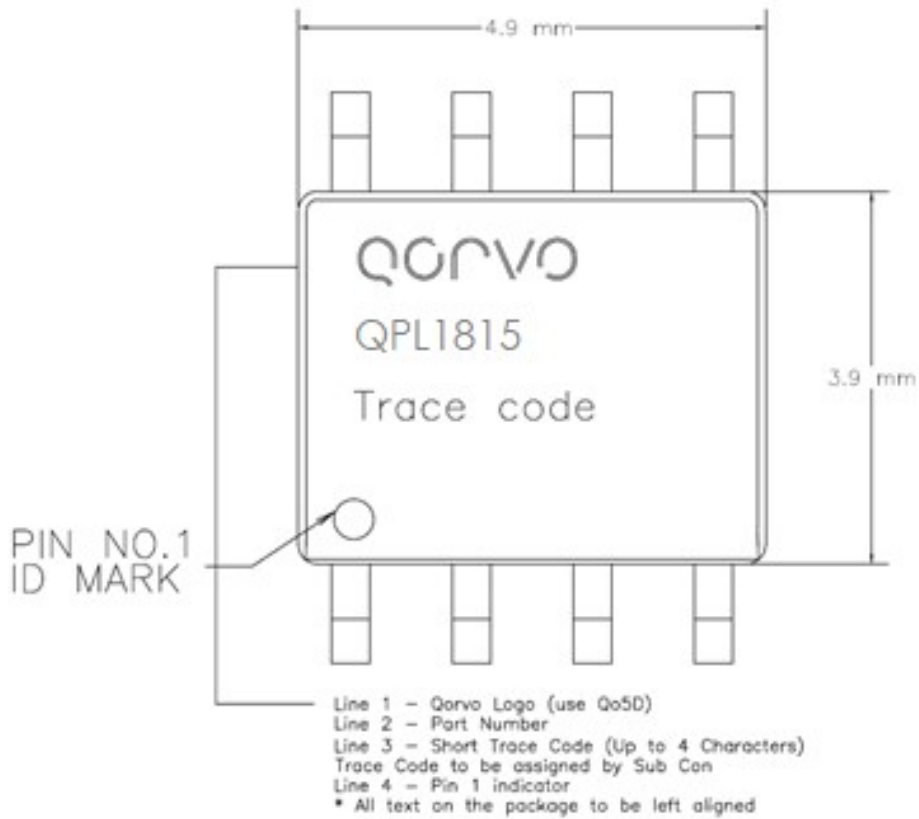

- Ensure that the backside via region makes good physical contact with the heat sink.

Pin Configuration and Description

Pin	Name	Description
1	RFIN1	RF input for plus side of amplifier
2	NC	No Connect
3	NC	No Connect
4	RFIN2	RF input for minus side of amplifier
5	RFOUT1	RF output for plus side of amplifier
6	NC	No Connect
7	NC	No Connect
8	RFOUT2	RF output for minus side of amplifier
9	GND	Exposed bottom of part, device ground

Package Outline

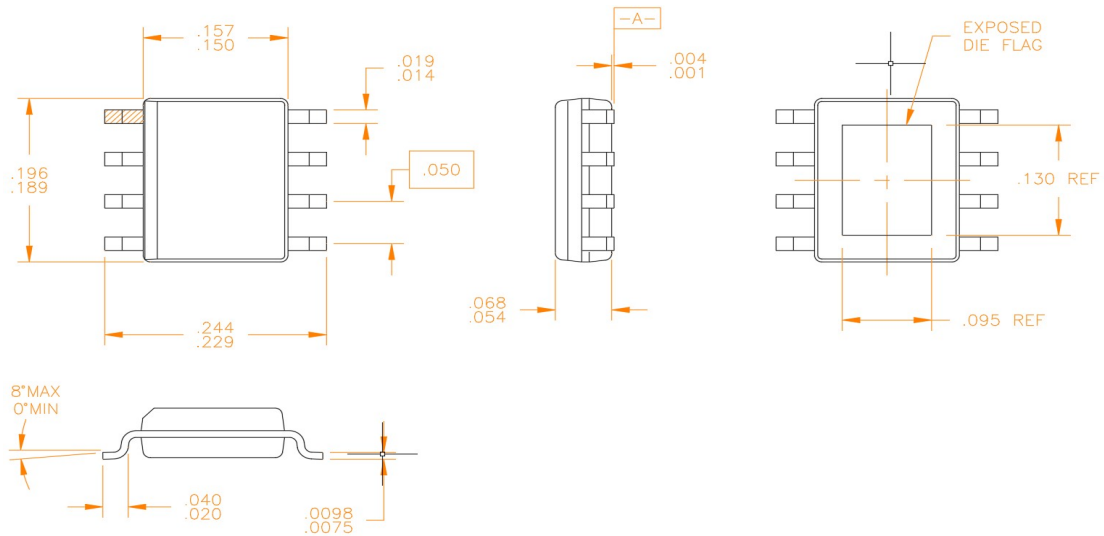

- Notes:
1. All Dimensions are in inches.
 2. Angles are in degrees.

Notes: All dimensions are in millimeters. Angles are in degrees.

Recommended Mounting Pattern

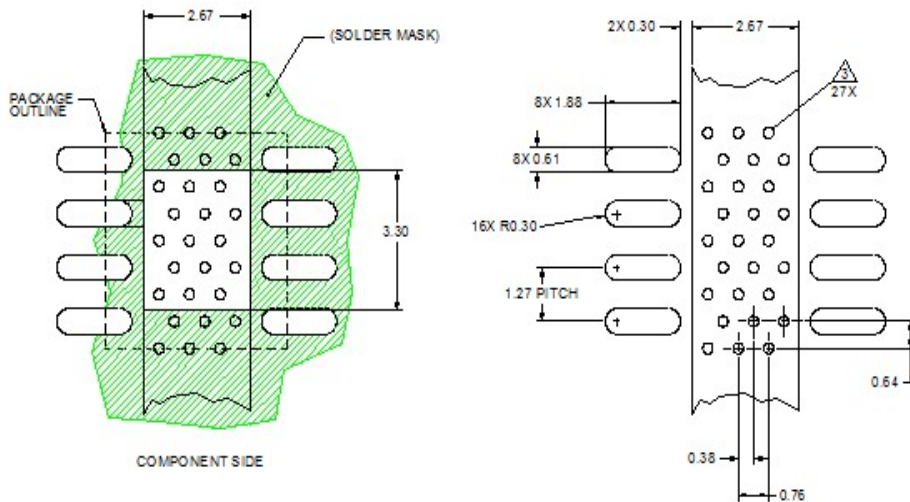

1. Use 1 oz. copper minimum for top and bottom layer metal.
2. Vias are required under the backside paddle for proper RF/DC grounding and thermal dissipation.
3. Recommend a 0.35 mm diameter bit for drilling via holes and a final plated thru diameter of 0.25 mm.