

General Description

The QPL9096 is a high-linearity, ultra-low noise gain block amplifier with a bypass mode functionality integrated in the product. At 2.5 GHz, the amplifier typically provides 25 dB gain, +33.5 dBm OIP3, and 0.75 dB noise figure while drawing 60 mA current from a +4.2 V supply.

The QPL9096 is internally matched using a high performance E-PHEMT process and only requires four external components for operation from a single positive supply: an external RF choke and blocking/bypass capacitors. This low noise amplifier contains an internal active bias to maintain high performance over temperature.

The QPL9096 is optimized for the 1.7–2.7 GHz frequency band and is targeted for wireless infrastructure. The QPL9096 is packaged in a 2x2 mm DFN.



8 Pin 2X2 mm DFN Package

Product Features

- 1.7 – 2.7 GHz Operational bandwidth
- LNA with integrated bypass mode
- Ability to turn LNA and bypass mode OFF
- Ultra low noise, 0.75 dB at 2.5 GHz
- 25 dB Gain at 2.5 GHz
- +33.5 dBm Output IP3 in LNA Mode
- +40 dBm Input IP3 in Bypass Mode
- Internally matched
- Positive supply only, +3.3 to +5 V
- 2x2 mm 8-pin DFN plastic package

Functional Block Diagram

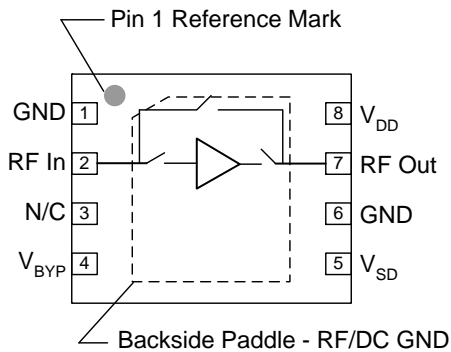

Top View

Applications

- Base-station Receivers
- Repeaters / DAS
- Tower Mounted Amplifiers
- Mobile Infrastructure
- General Purpose Wireless
- TDD or FDD systems

Ordering Information

Part No.	Description
QPL9096SR	100 pcs on 7" reel
QPL9096TR7	2500 pcs on 7" reel
QPL9096EVB01 ⁽¹⁾	Evaluation Board

1. Refer board details and performance on pgs. 3 & 4.

Absolute Maximum Ratings

Parameter	Rating
Storage Temperature	-65 to 150°C
Supply Voltage (V _{DD})	+7 V
RF Input Power, CW, 50Ω, T=25°C	+30 dBm

Operation of this device outside the parameter ranges given above may cause permanent damage.

Recommended Operating Conditions

Parameter	Min	Typ	Max	Units
Supply Voltage (V _{DD})	3.0	4.2	5.25	V
T _{CASE}	-40		+105	°C
T _j at T _{CASE} = 125°C			+142	°C

Electrical specifications are measured at specified test conditions. Specifications are not guaranteed over all recommended operating conditions.

Electrical Specifications

Test conditions unless otherwise noted: V_{DD} = +4.2 V, Temp.=+25°C.

Parameter	Conditions	Min	Typ	Max	Units
Operational Frequency Range		1700		2700	MHz
Test Frequency			2500		MHz
Gain	LNA ON, Bypass OFF	23.5	25	26.5	dB
Input Return Loss	LNA ON, Bypass OFF		20		dB
Output Return Loss	LNA ON, Bypass OFF		6		dB
Noise Figure ⁽²⁾	LNA ON, Bypass OFF		0.75	1.1	dB
Output P1dB	LNA ON, Bypass OFF	+15.5 ⁽¹⁾	+17		dBm
Output IP3	LNA ON, Bypass OFF, P _{out} =+0 dBm/tone, Δf=5 MHz	+30	+33.5		dBm
Insertion Loss	LNA OFF, Bypass ON		1.4	3	dB
Return Loss	LNA OFF, Bypass ON		12		dB
Isolation ⁽¹⁾	LNA OFF, Bypass OFF	15	18		dB
Output IP3	LNA OFF, Bypass ON P _{in} =+3 dBm/tone, Δf=5 MHz	+33	+40		dBm
Control Voltage, V ₁ , V ₂	V _{IH}	1.17		V _{DD}	V
	V _{IL}	0		0.63	V
Current, I _D	Bypass OFF	40	55	75	mA
	Bypass ON		3.5		mA
Switching Speed	LNA-Bypass (50% V _{ctrl} to 10% RF)		200		ns
	Bypass-LNA(50% V _{ctrl} to 90% RF)		330		ns
	LNA-OFF(50% V _{ctrl} to 10% RF)		26		ns
	OFF-LNA(50% V _{ctrl} to 90% RF)		65		ns
Thermal Resistance, θ _{jc}	Channel to case		44		°C/W

1. Minimum specification listed is guaranteed by design. Not tested in production.
2. Input trace loss de-embedded from noise figure data.

Control Truth Table

V _{BYP}	V _{SD}	State
0	0	LNA ON, Bypass OFF
0	1	LNA OFF, Bypass OFF
1	x	LNA OFF, Bypass ON

QPL9096 Evaluation Board

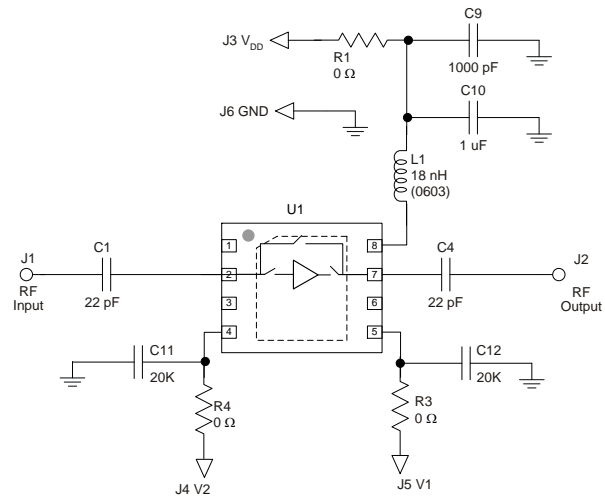
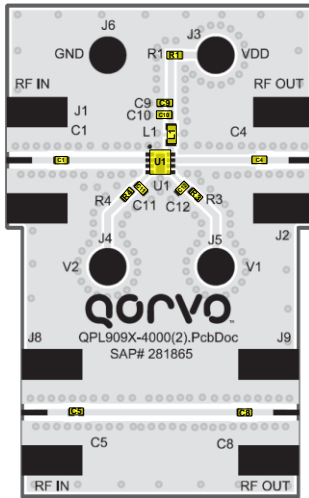

Notes:

1. A through line is included on the evaluation board to de-embed the board losses.

Bill of Material – QPL9096 Evaluation Board

Reference Des.	Value	Description	Manuf.	Part Number
N/A	N/A	Printed Circuit Board	Qorvo	
U1	n/a	Ultra Low Noise, Bypass LNA	Qorvo	QPL9096
C1, C4, C5, C8	22 pF	CAP, 0402, +/-0.1pF, 25V	Various	
C9	1000 pF	CAP, 0402, 10%, 50V, X7R	Murata	GRM155R71H102KA01D
C10	1.0 uF	Cap., 0402, 10%, 6.3V, X5R	Murata	GRM155R60J105KE19D
C11, C12	20K	RES, chip, 0402, 5%	Various	
R1, 3, 4	0 Ω	Resistor, Chip, 0402, 5%, 1/16W	various	
L1	18 nH	Inductor, 0402, 5%, coil	Coilcraft	0402CS-18NXJL

Performance Plots

Test conditions unless otherwise noted: $V_{DD} = +4.2\text{ V}$

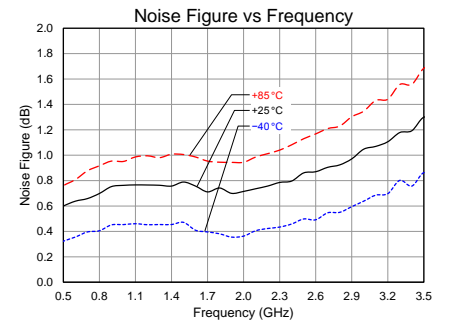
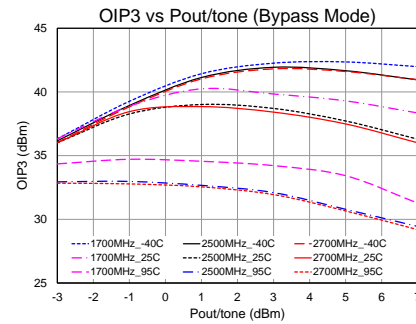
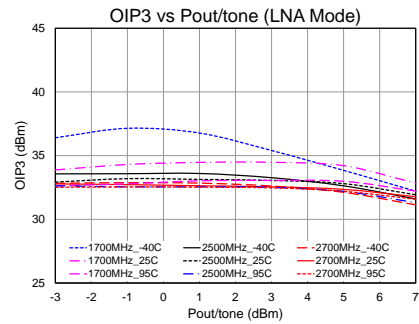
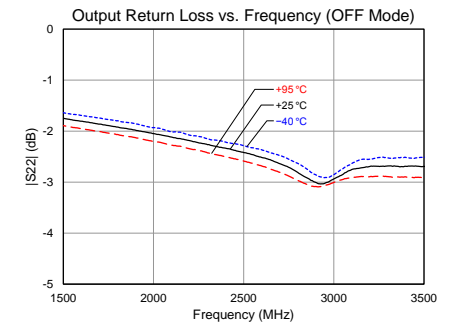
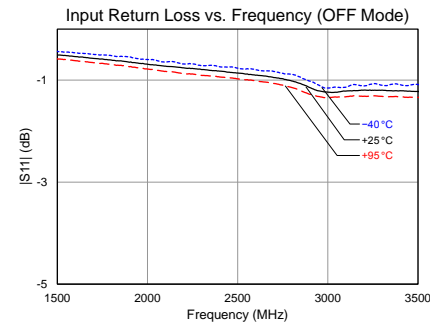
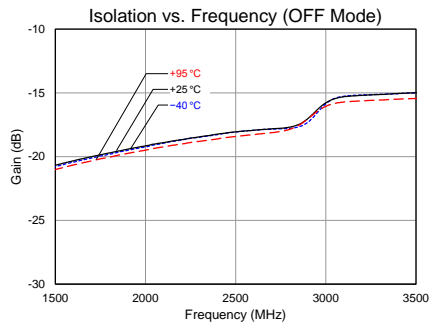
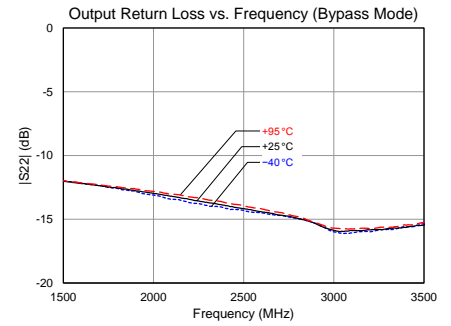
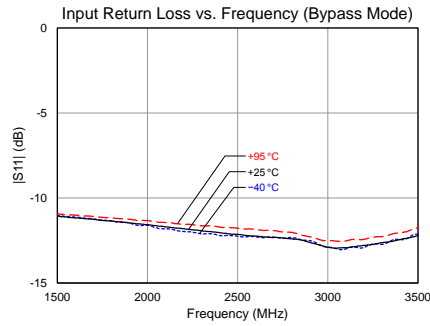
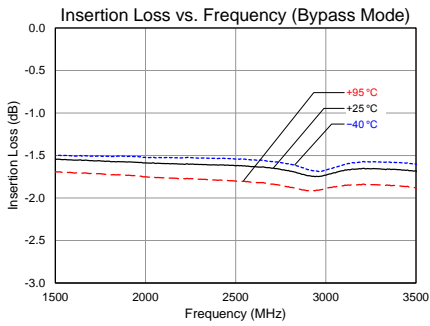
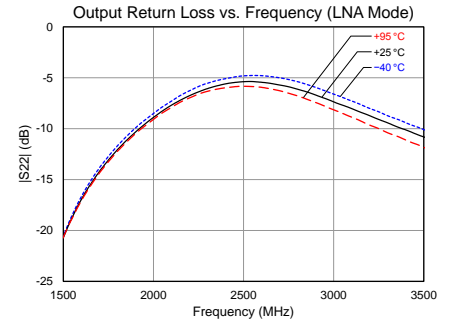
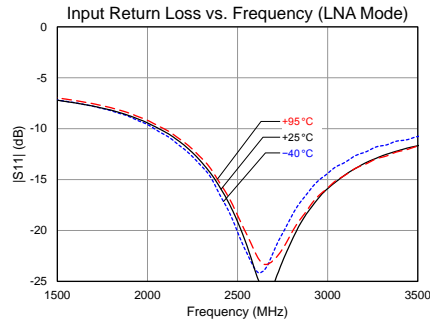
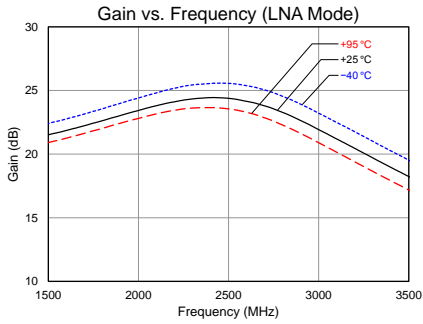

QPL9096 1700-1900 MHz Tune

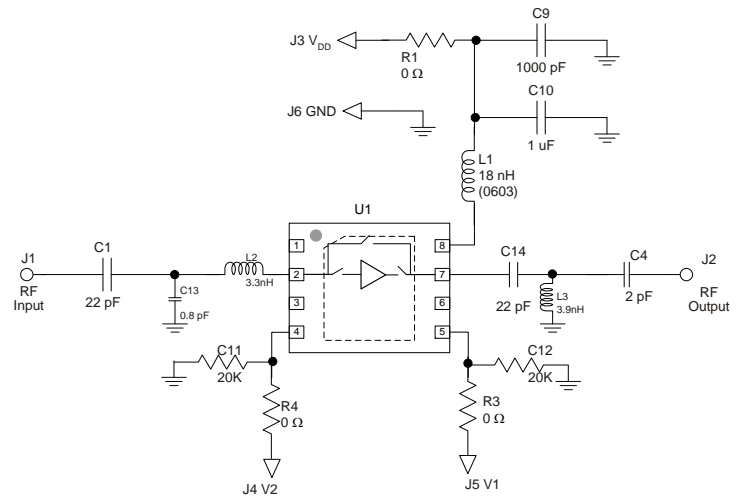
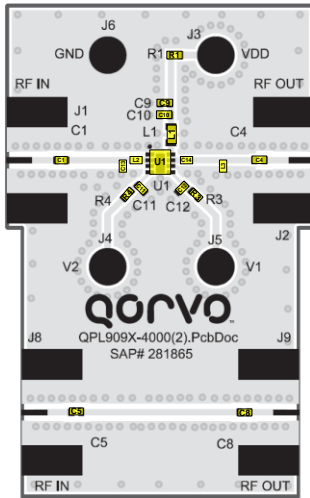

Notes:

1. A through line is included on the evaluation board to de-embed the board losses.

Performance Plots-1700-1900 MHz Tune

Test conditions unless otherwise noted: $V_{DD} = +4.2\text{ V}$, $Temp. = +25\text{ }^\circ\text{C}$

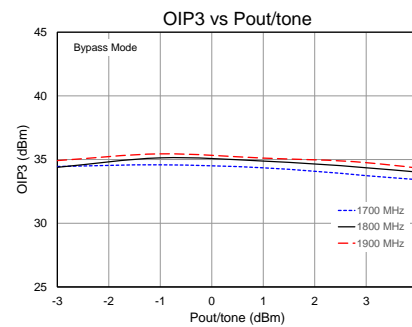
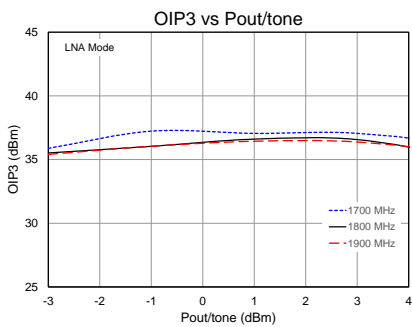
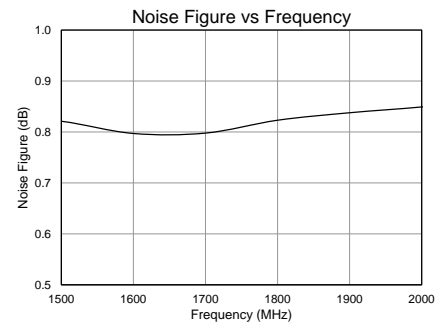
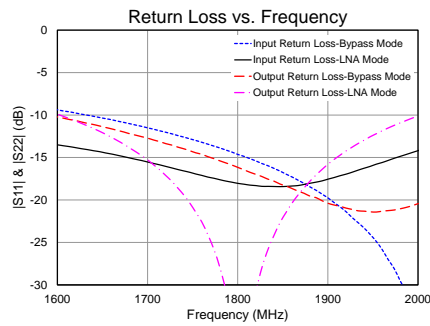
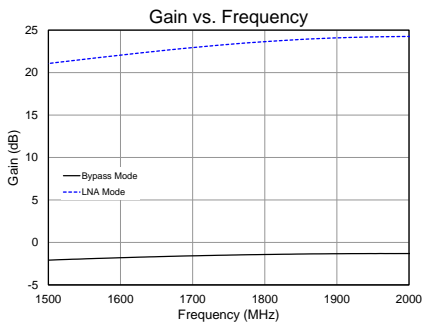

QPL9096 1900-2100 MHz Tune

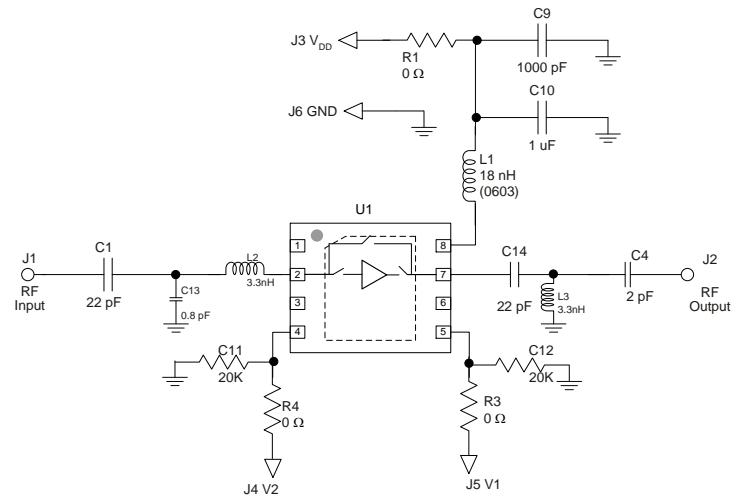
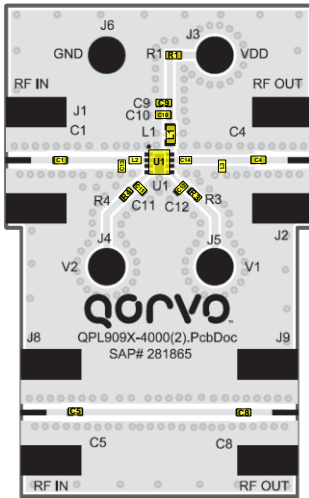

Notes:

1. A through line is included on the evaluation board to de-embed the board losses.

Performance Plots-1900-2100 MHz Tune

Test conditions unless otherwise noted: $V_{DD} = +4.2\text{ V}$, $Temp. = +25\text{ }^{\circ}\text{C}$

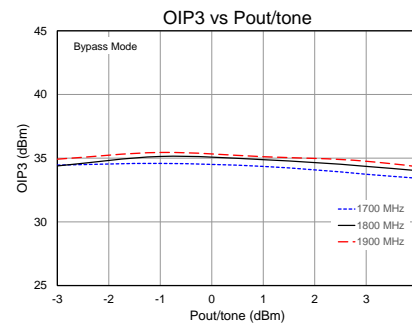
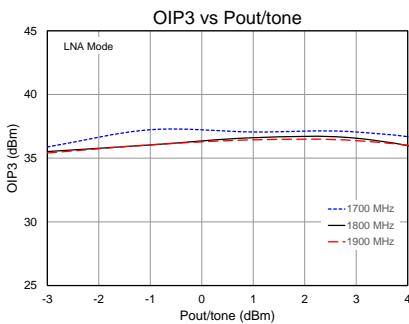
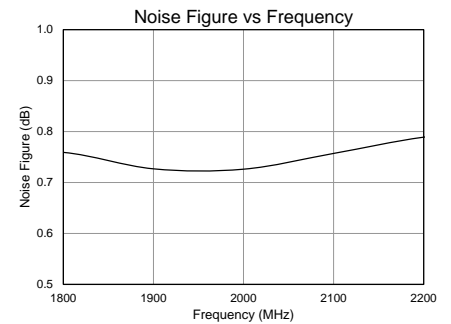
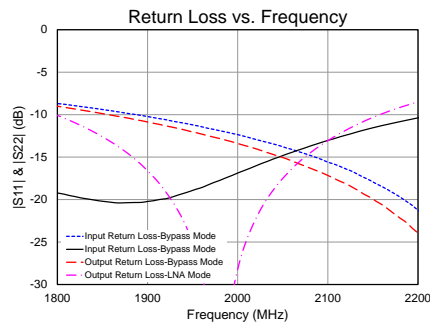
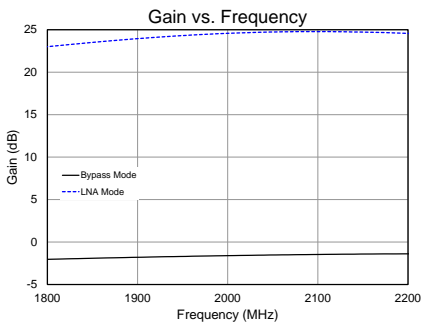

QPL9096 2500-2700 MHz Tune

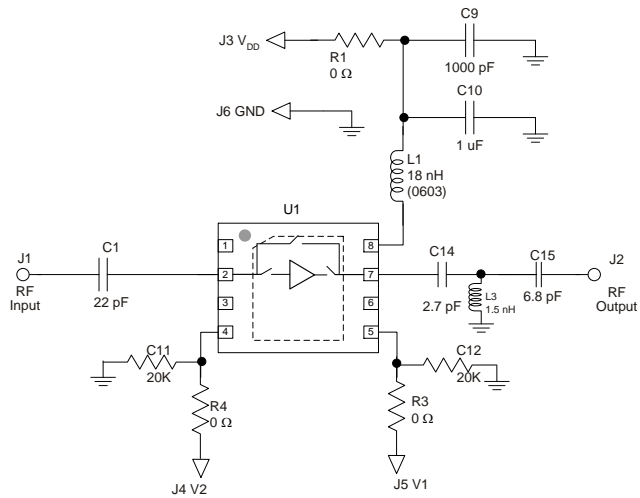
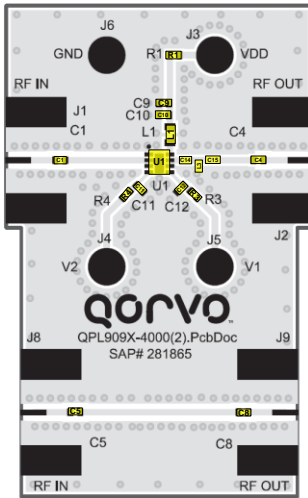

Notes:

1. A through line is included on the evaluation board to de-embed the board losses.

Performance Plots 2500-2700 MHz Tune

Test conditions unless otherwise noted: $V_{DD} = +4.2\text{ V}$, $Temp. = +25\text{ }^{\circ}\text{C}$

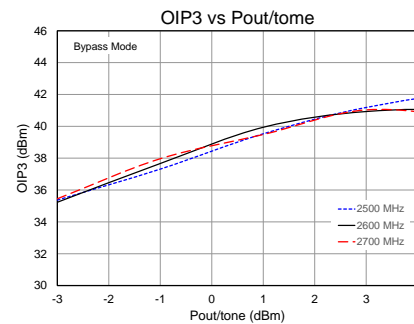
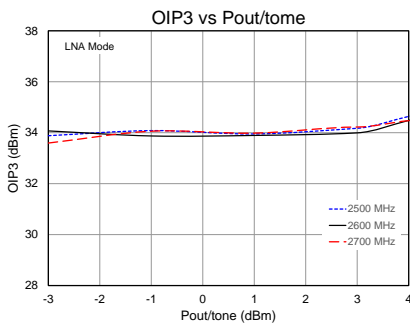
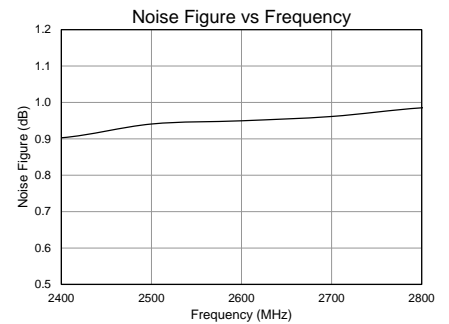
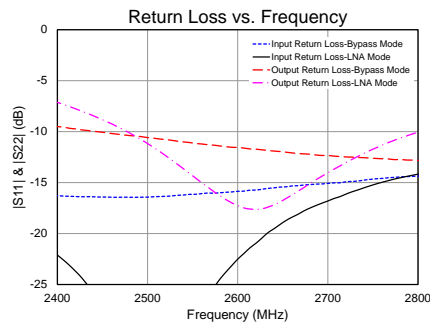
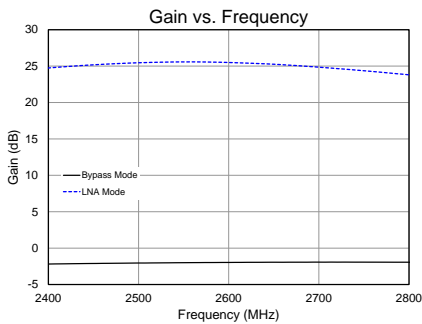

Pin Configuration and Description

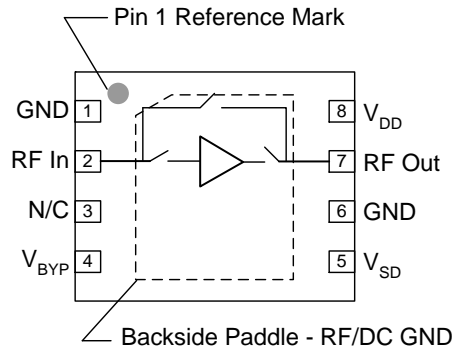

Pin No.	Label	Description
1, 6	GND	RF/DC Ground pin.
2	RFin	RF input pin. DC block required.
3	N/C	No internal connection. Provide grounded PCB land pads for mounting integrity.
4	V _{BYP}	Control pin for bypass mode. The LNA is automatically turned off when the bypass mode is activated. Refer to truth table on pg 2.
5	V _{SD}	Control pin to disable the LNA. Refer to truth table on pg. 2.
7	RFout	RF output pin. DC block required.
8	V _{DD}	Supply voltage pin. External choke and bypass capacitors needed.
Backside Paddle	RF/DC GND	RF/DC Ground. Follow recommended via pattern and ensure good solder attach for best thermal and electrical performance.

Evaluation Board PCB Information

Qorvo PCB 281865 Material and Stack-up

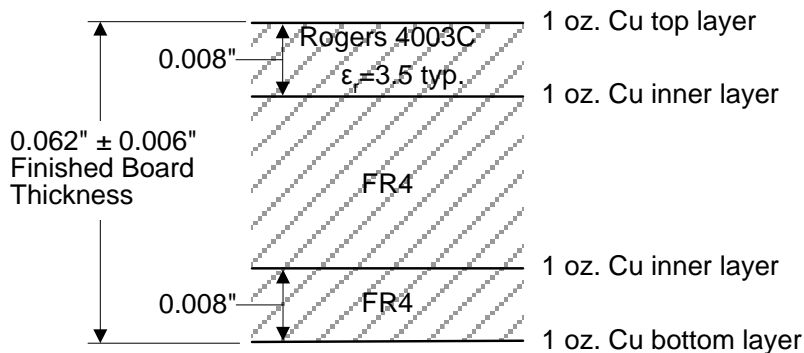

50 ohm line dimensions: width = 0.0182", spacing = 0.020"

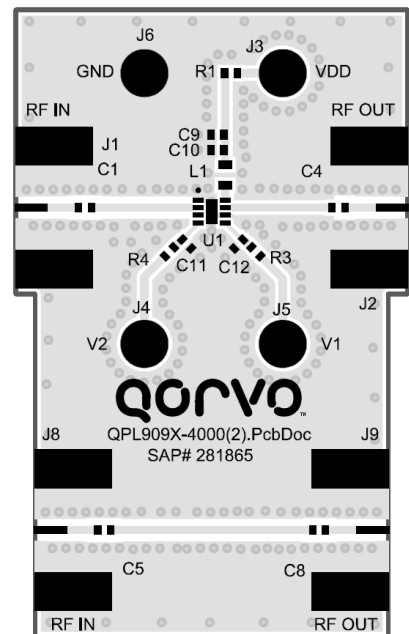

Mechanical Information

Package Marking and Dimensions

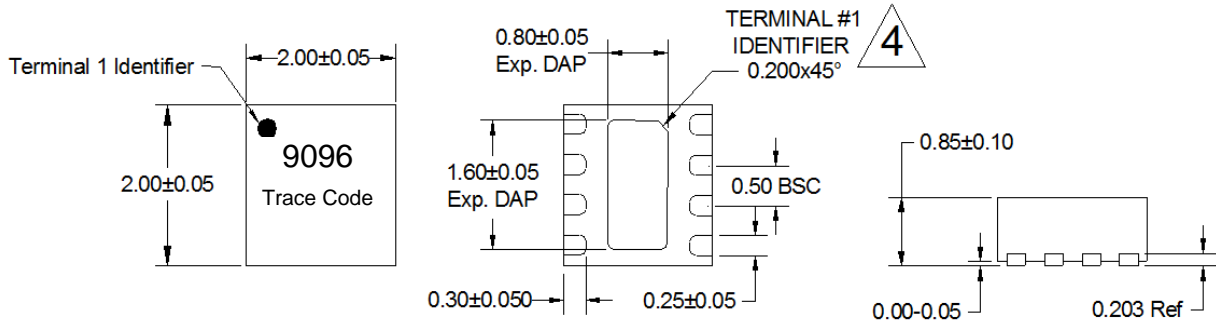

Notes:

1. All dimensions are in millimeters. Angles are in degrees.
2. Except where noted, this part outline conforms to JEDEC standard MO-220, Issue E (Variation VGGC) for thermally enhanced plastic very thin fine pitch quad flat no lead package (QFN).
3. Dimension and tolerance formats conform to ASME Y14.4M-1994.
4. The terminal #1 identifier and terminal numbering conform to JESD 95-1 SPP-012.

PCB Mounting Pattern

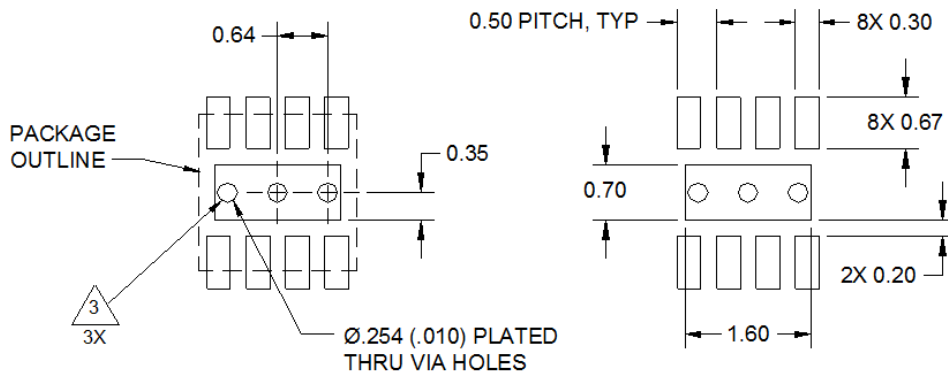

Notes:

1. All dimensions are in millimeters. Angles are in degrees.
2. Use 1 oz. copper minimum for top and bottom layer metal.
3. Vias are required under the backside paddle of this device for proper RF/DC grounding and thermal dissipation. We recommend a 0.35 mm ($\#80/.0135$ ") diameter bit for drilling via holes and a final plated thru diameter of 0.25 mm (0.10 ").
4. Ensure good package backside paddle solder attach for reliable operation and best electrical performance.