

Product Overview

Qorvo’s QPM1021 is a packaged, high power amplifier fabricated on Qorvo’s production 0.15 μm GaN on SiC process. The QPM1021 operates from 10–12 GHz and provides 100 W (50 dBm) of saturated output power with 20 dB of large signal gain and greater than 32 % power-added efficiency.

The QPM1021 is packaged in a 10-lead 19.05 x 19.05 mm bolt-down package, with a pure copper base for superior thermal management. Both RF ports are internally DC blocked and matched to 50 ohms allowing for simple system integration.

The QPM1021 is ideally suited for both commercial and military radar systems, satellite communications systems, and data links.

Lead-free and RoHS compliant.

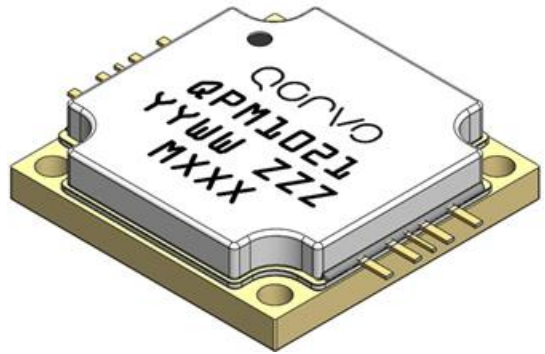

Key Features

- Frequency Range: 10 – 12 GHz
- P_{SAT} : > 50 dBm ($P_{IN} = 28$ dBm)
- PAE: > 32% ($P_{IN} = 28$ dBm)
- Large Signal Gain: > 20 dB ($P_{IN} = 28$ dBm)
- Small Signal Gain: > 26 dB
- Bias: $V_D = 28$ V, $I_{DQ} = 2.0$ A
- Package Dimensions: 19.05 x 19.05 x 4.52 mm
- Performance Under Pulsed Operation

Performance is typical across frequency. Please reference electrical specification table and data plots for more details.

Functional Block Diagram

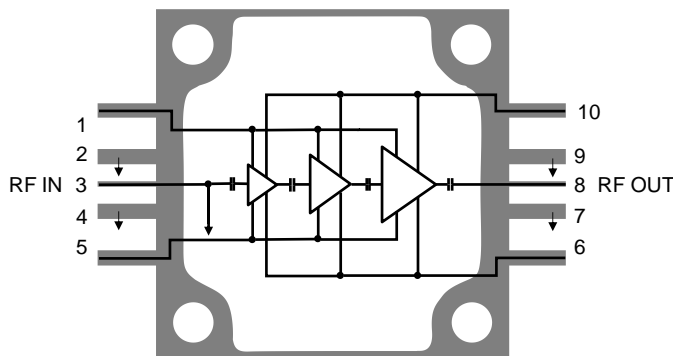

Top View

Applications

- Radar
- Electronic Warfare

Ordering Information

Part No.	Description
QPM1021	10–12 GHz 100 Watt GaN Power Amplifier (10 pcs.)
QPM1021S2	QPM1021 Samples (2 pcs.)
QPM1021EVB	QPM1021 Evaluation Board

Absolute Maximum Ratings

Parameter	Rating
Drain Voltage (V_D)	29.5 V
Gate Voltage Range (V_G)	-5 to 0 V
Drain Current (I_D)	18.2 A
Gate Current (I_G)	See plot pg. 11
Power Dissipation (P_{DISS}), 85 °C, Pulsed; PW = 150 μ s, DC = 20%	435 Watts
Input Power (P_{IN}), 50 Ω , 85 °C, $V_D = 28$ V, Pulsed; PW = 150 μ s, DC = 20%	32 dBm
Input Power (P_{IN}), 85 °C, VSWR 3:1, $V_D = 28$ V, Pulsed; PW = 150 μ s, DC = 20%	38 dBm
Lead Soldering Temperature (30 seconds)	260 °C
Storage Temperature	-55 to 150 °C

Exceeding any one or a combination of the Absolute Maximum Rating conditions may cause permanent damage to the device. Extended application of Absolute Maximum Rating conditions to the device may reduce device reliability.

Recommended Operating Conditions

Parameter	Min	Typ	Max	Units
Drain Voltage (V_D)		28		V
Drain Current (I_{DQ})		2.0		A
Operating Temperature Range	-40	25	85	°C

Electrical specifications are measured at specified test conditions. Specifications are not guaranteed over all recommended operating conditions.

Electrical Specifications

Parameter	Conditions ⁽¹⁾	Min	Typ	Max	Units
Frequency Range		10		12	GHz
Output Power	$P_{IN} = 28$ dBm, Pulsed	10 GHz	51.3		dBm
		11 GHz	50.5		
		12 GHz	50.4		
Power Added Efficiency	$P_{IN} = 28$ dBm, Pulsed	10 GHz	32.9		%
		11 GHz	31.0		
		12 GHz	26.2		
Power Gain	$P_{IN} = 28$ dBm, Pulsed	10 GHz	23.4		dB
		11 GHz	22.6		
		12 GHz	22.5		
P_{OUT} Temperature Coefficient	Temp: 25 °C to 85 °C, $P_{IN} = 28$ dBm)		-0.012		dB/°C
Small Signal Gain		10 GHz	26.6		dB
		11 GHz	24.0		
		12 GHz	20.2		
Input Return Loss			13		dB
Output Return Loss			11		dB
Small Sig. Gain Temp. Coefficient	Temp: -40°C to 85 °C		-0.110		dB/°C
Recommended Operating Voltage		24	28	28	V

Notes:

Test conditions unless otherwise noted: T = 25 °C, $V_D = 28$ V, $I_{DQ} = 2.0$ A, PW = 150 μ s, Duty Cycle = 20%

Performance Plots – Large Signal

Test conditions unless otherwise noted: $T = 25\text{ }^{\circ}\text{C}$, $V_D = 28\text{ V}$, $I_{DQ} = 2.0\text{ A}$, $P_{IN} = 28\text{ dBm}$, $PW = 150\text{ }\mu\text{s}$, Duty Cycle = 20%

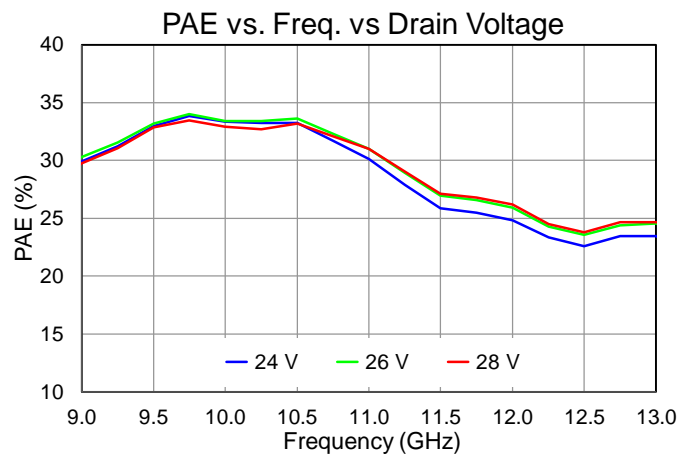
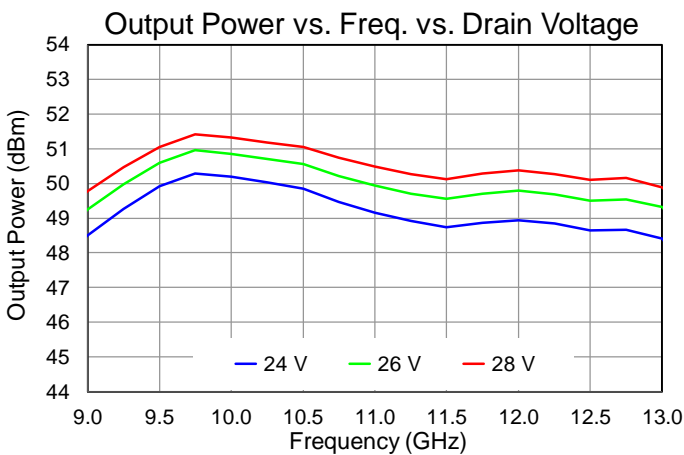
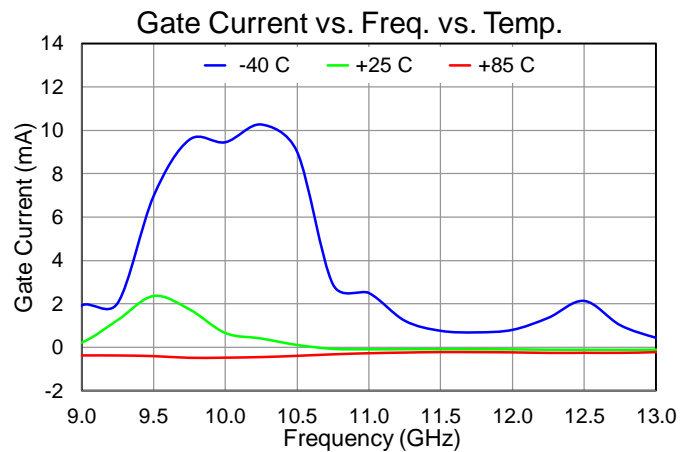
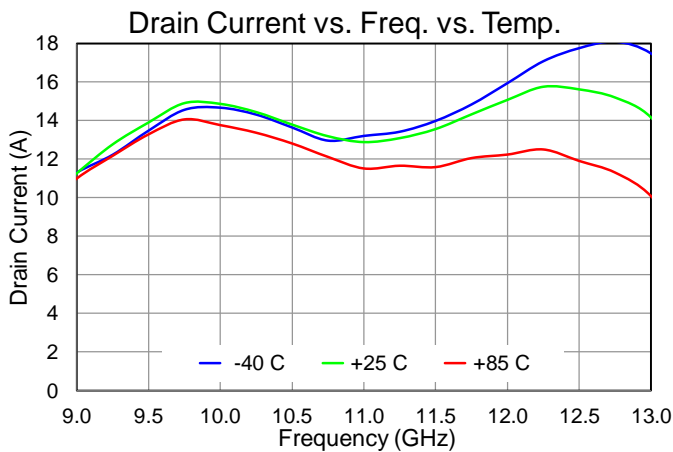
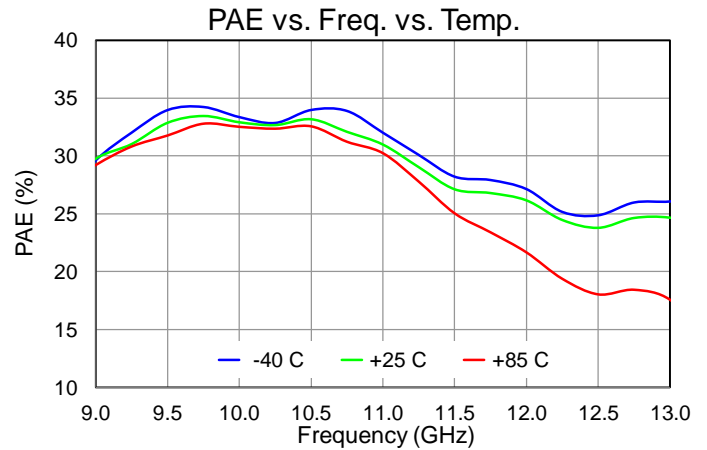
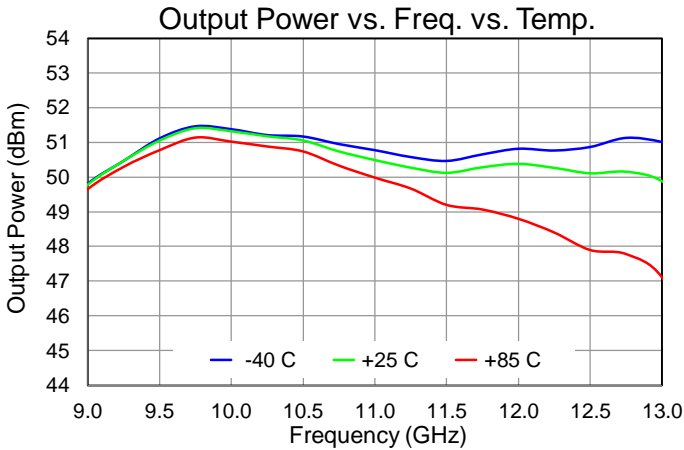

Performance Plots – Large Signal

Test conditions unless otherwise noted: $T = 25\text{ }^{\circ}\text{C}$, $V_D = 28\text{ V}$, $I_{DQ} = 2.0\text{ A}$, $P_{IN} = 28\text{ dBm}$, $PW = 150\text{ }\mu\text{s}$, Duty Cycle = 20%

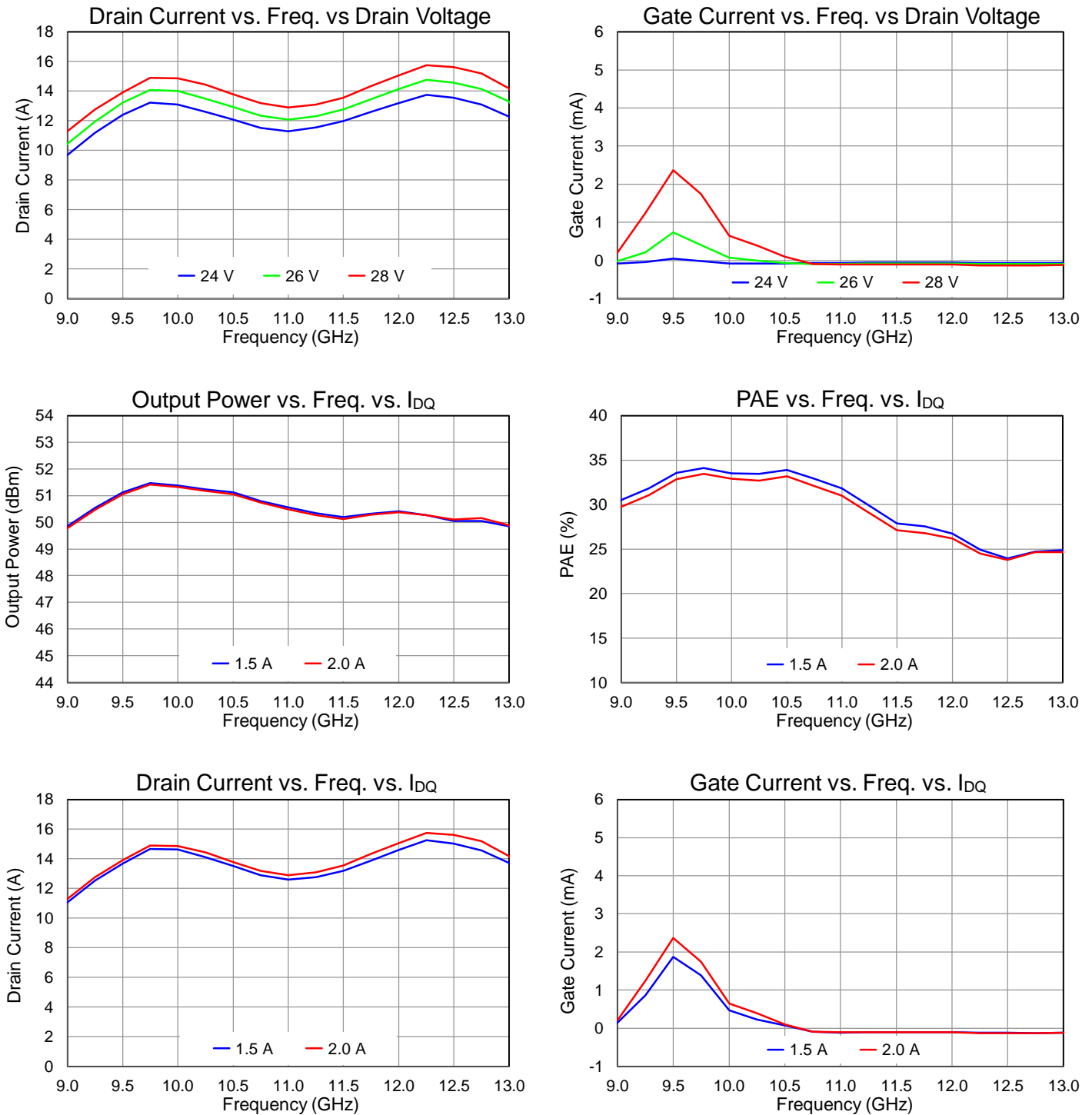

Performance Plots – Large Signal

Test conditions unless otherwise noted: $T = 25\text{ }^{\circ}\text{C}$, $V_D = 28\text{ V}$, $I_{DQ} = 2.0\text{ A}$, $P_{IN} = 28\text{ dBm}$, $PW = 150\text{ }\mu\text{s}$, Duty Cycle = 20%

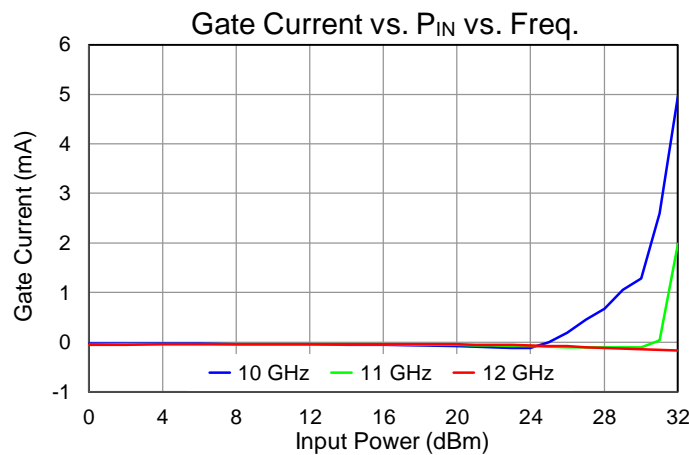
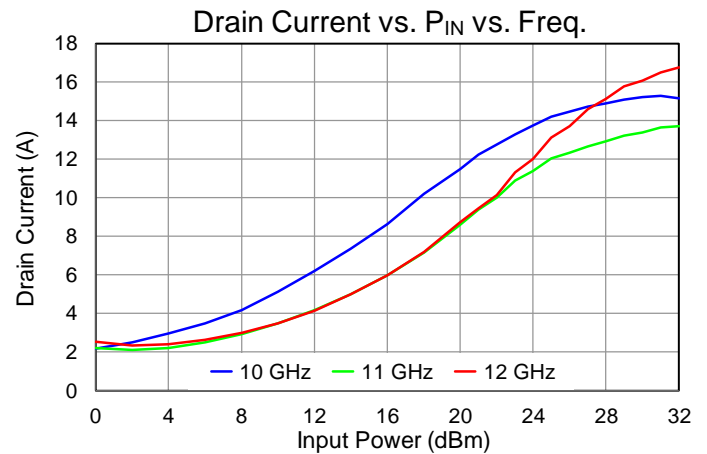
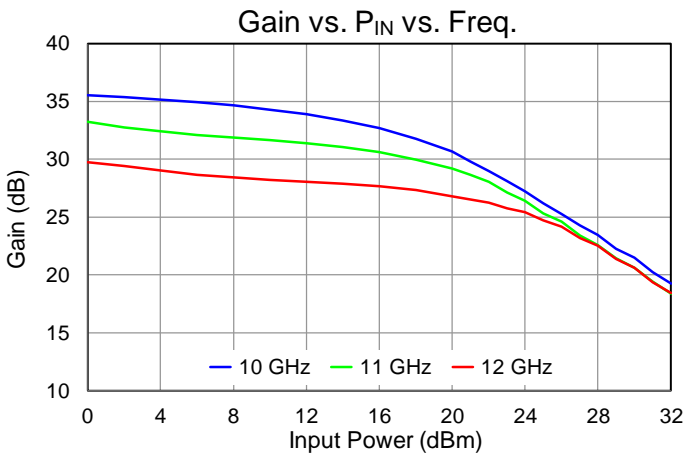
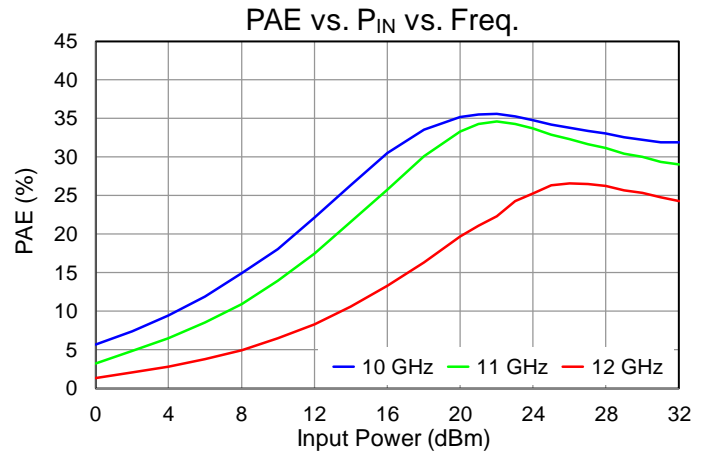
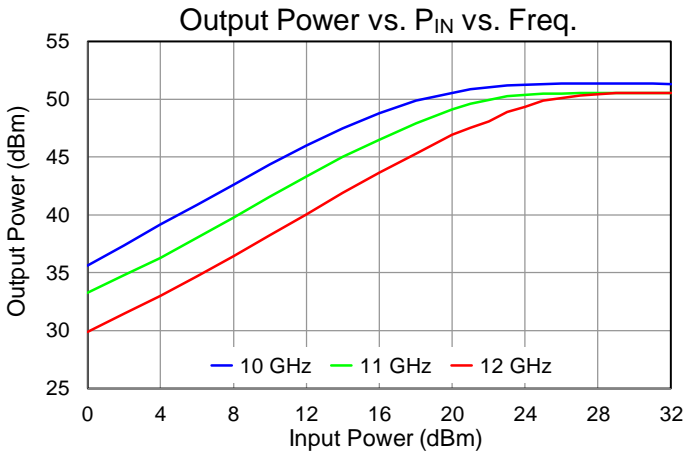

Performance Plots – Large Signal

Test conditions unless otherwise noted: $T = 25\text{ }^{\circ}\text{C}$, $V_D = 28\text{ V}$, $I_{DQ} = 2.0\text{ A}$, $\text{Freq} = 11\text{ GHz}$, $\text{PW} = 150\text{ }\mu\text{s}$, $\text{Duty Cycle} = 20\%$

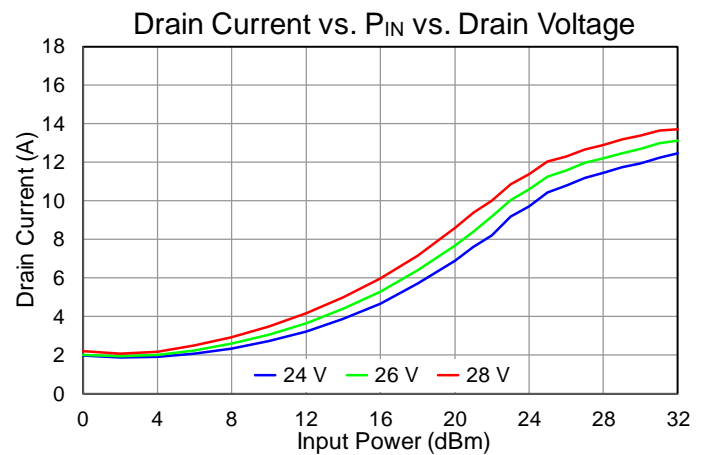
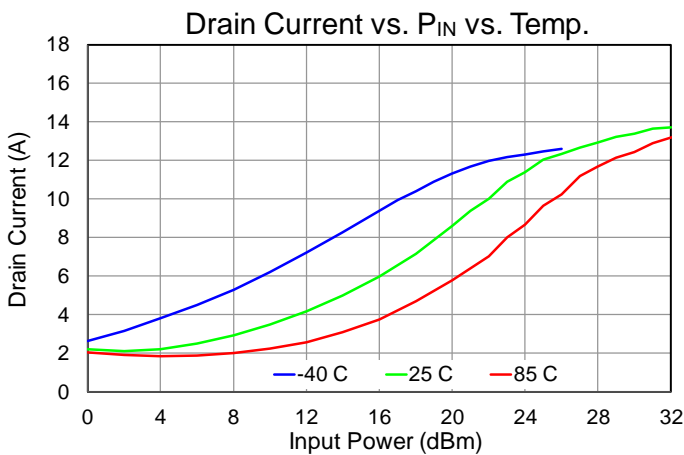
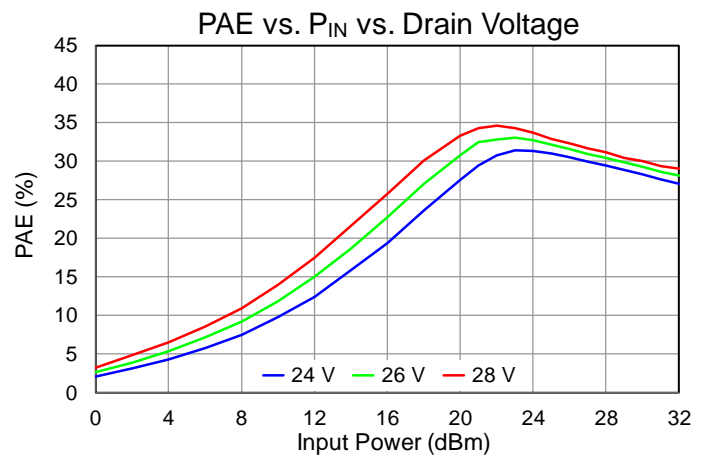
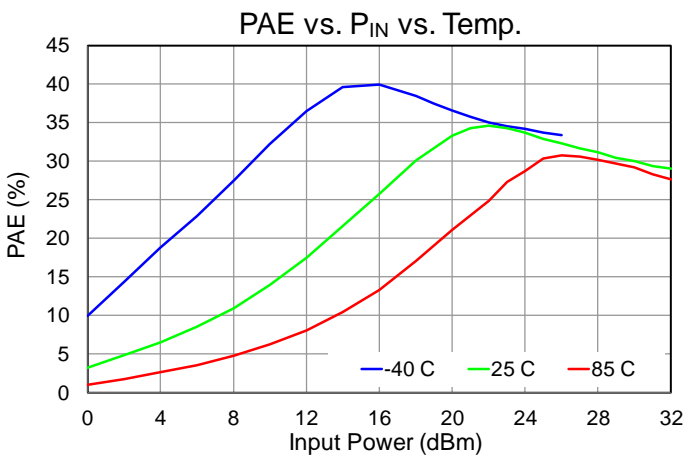
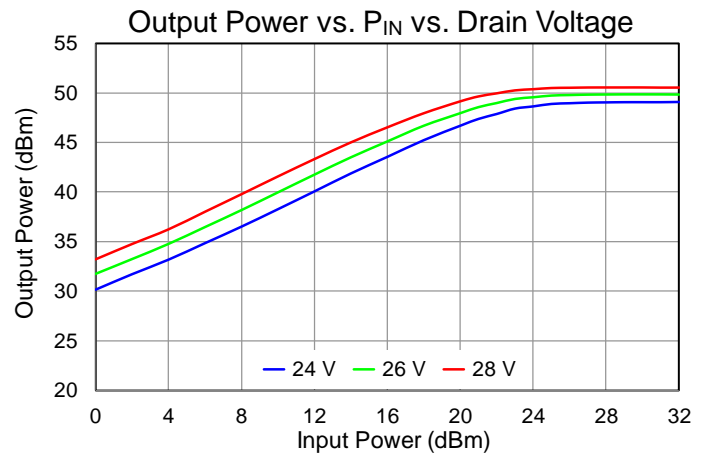
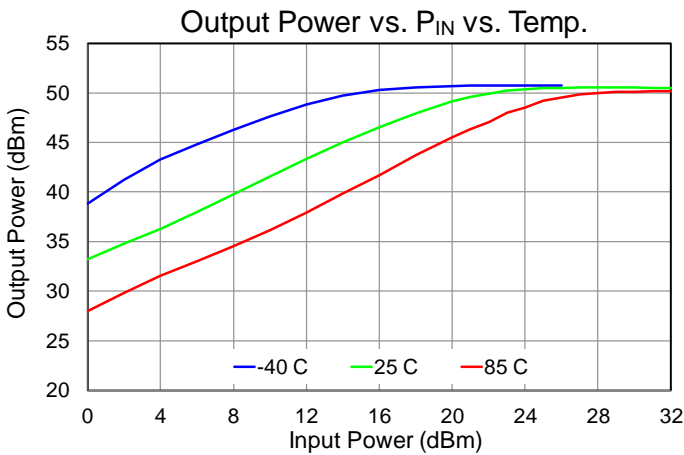

Performance Plots – Large Signal

Test conditions unless otherwise noted: T = 25 °C, V_D = 28 V, I_{DQ} = 2.0 A, Freq = 11 GHz, PW = 150 us, Duty Cycle = 20%

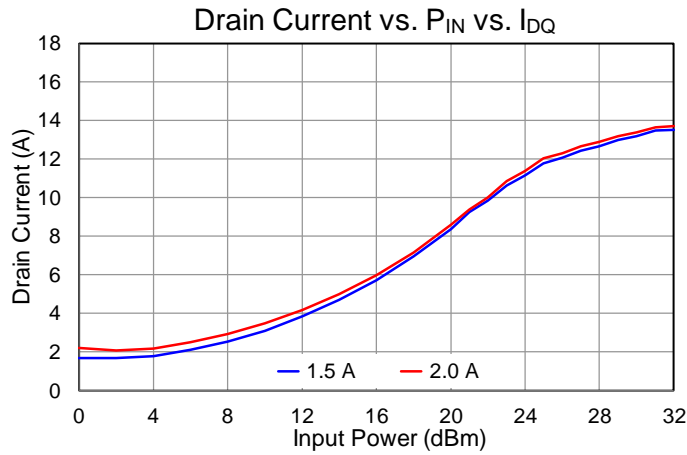
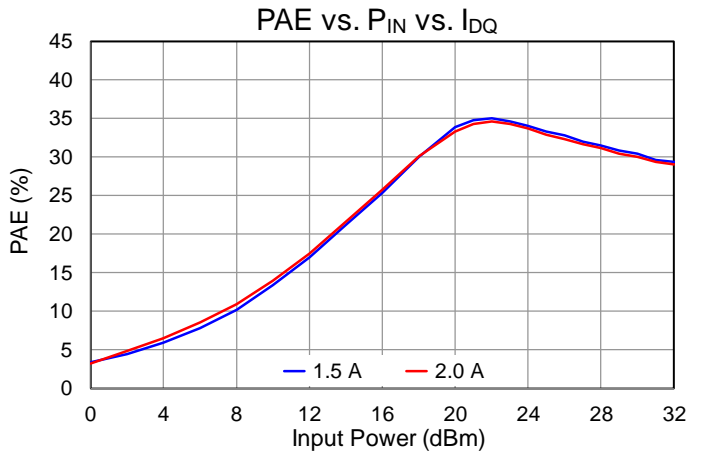
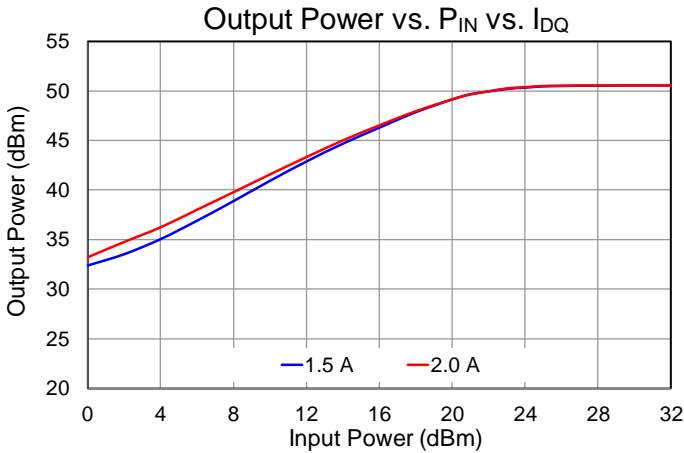

Performance Plots – Harmonics

Test conditions unless otherwise noted: T = 25 °C, V_D = 28 V, I_{DQ} = 2.0 A, PW = 150 us, Duty Cycle = 20%

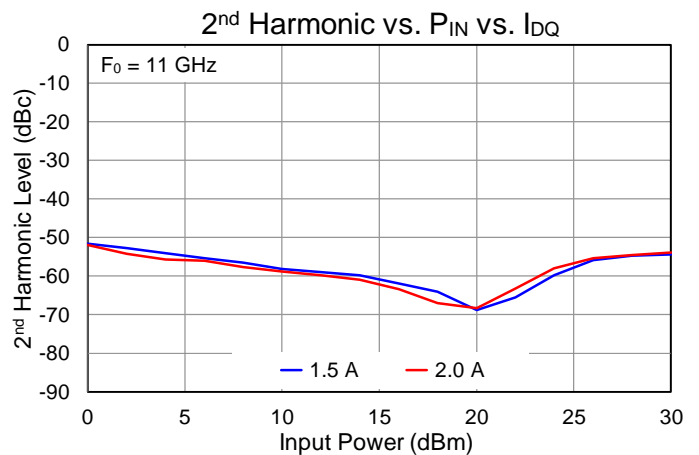
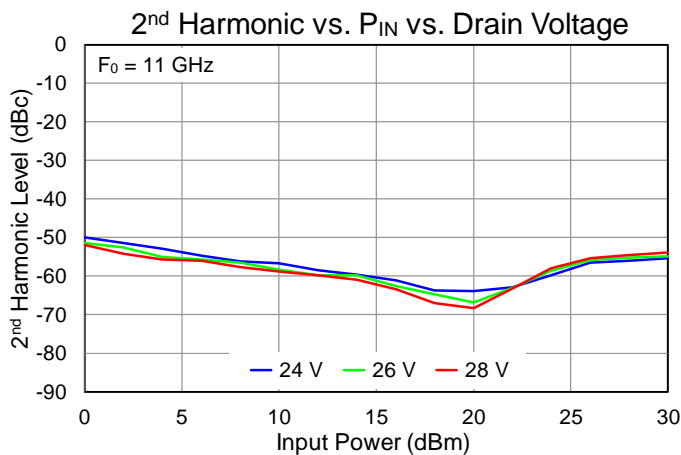
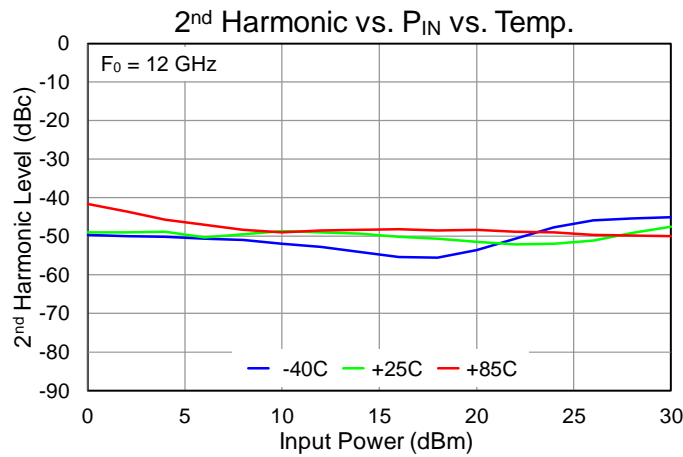
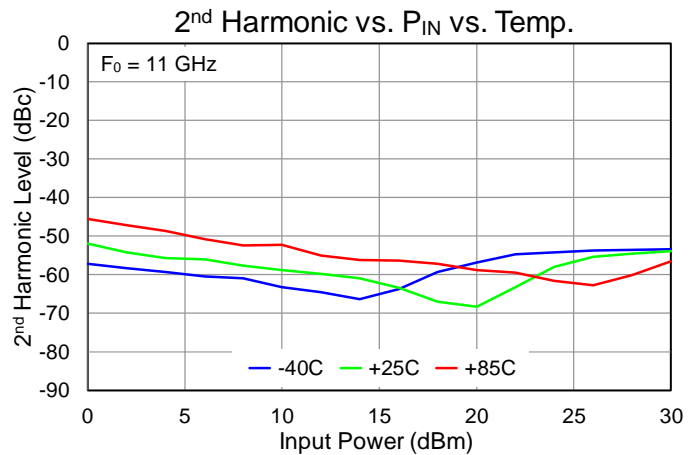
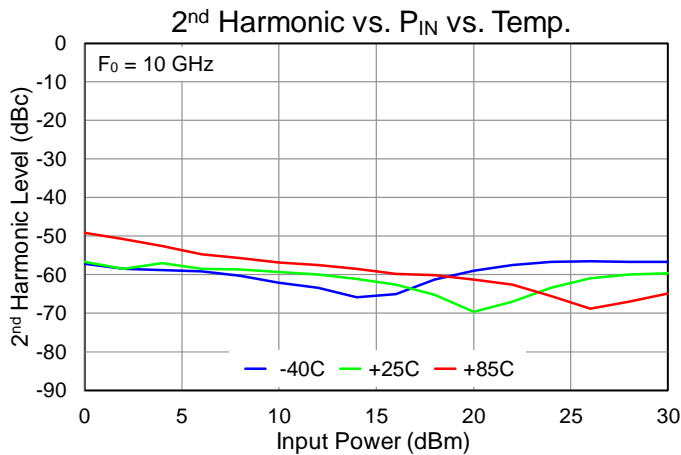

Performance Plots – Small Signal

Test conditions unless otherwise noted: T = 25 °C, V_D = 28 V, I_{bq} = 2.0 A

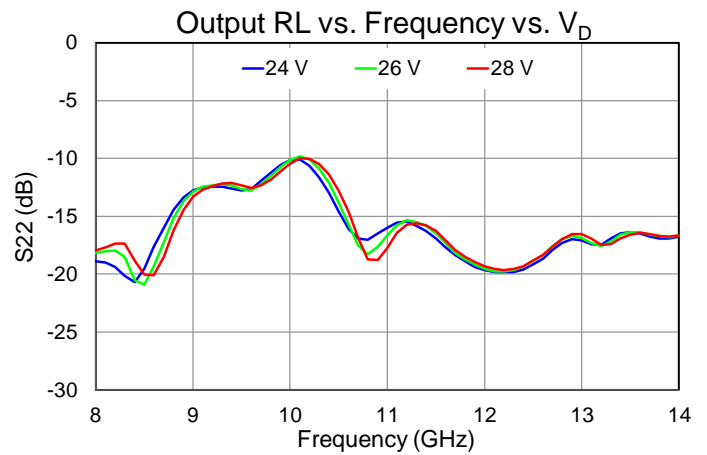
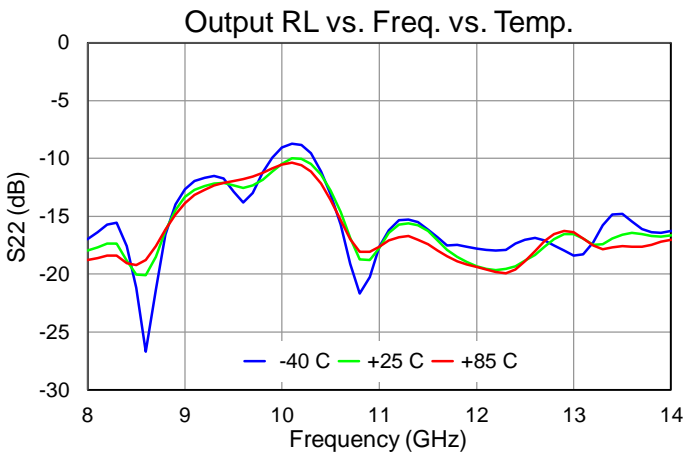
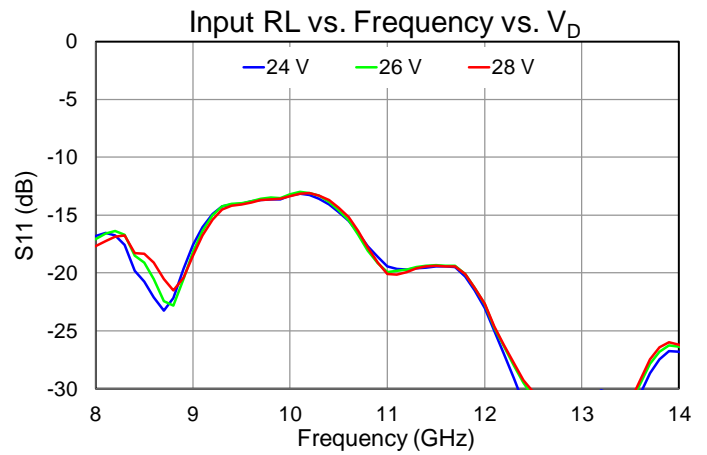
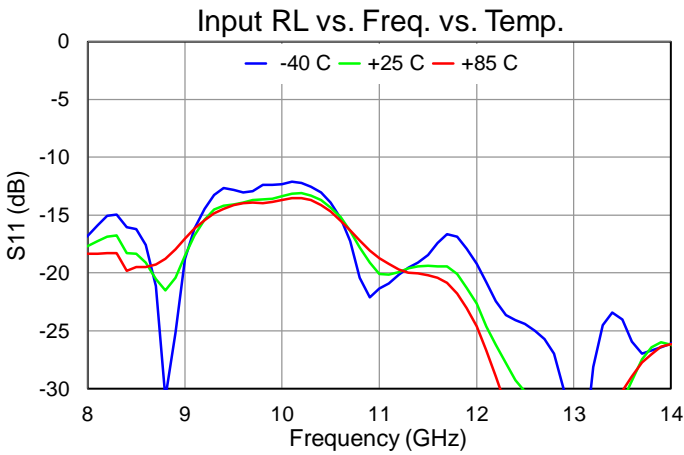
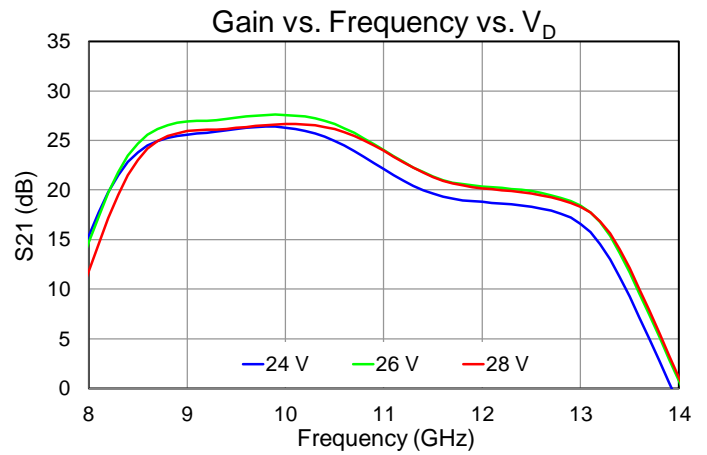
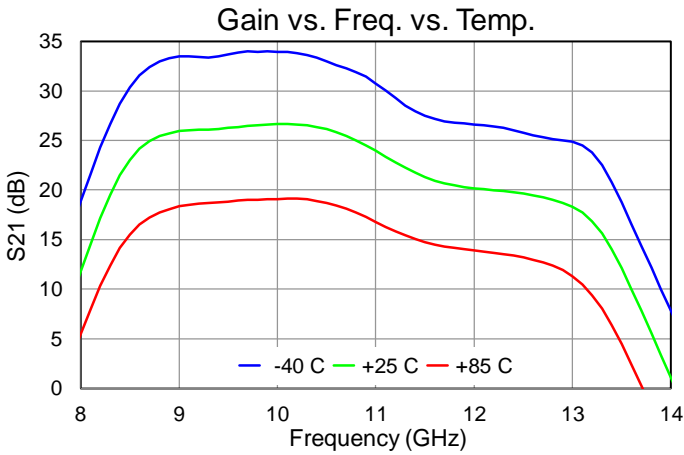

Performance Plots – Small Signal

Test conditions unless otherwise noted: T = 25 °C, V_D = 28 V, I_{DQ} = 2.0 A

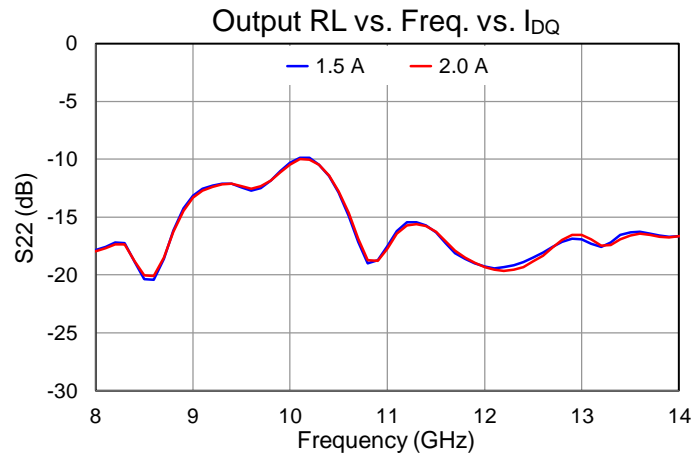
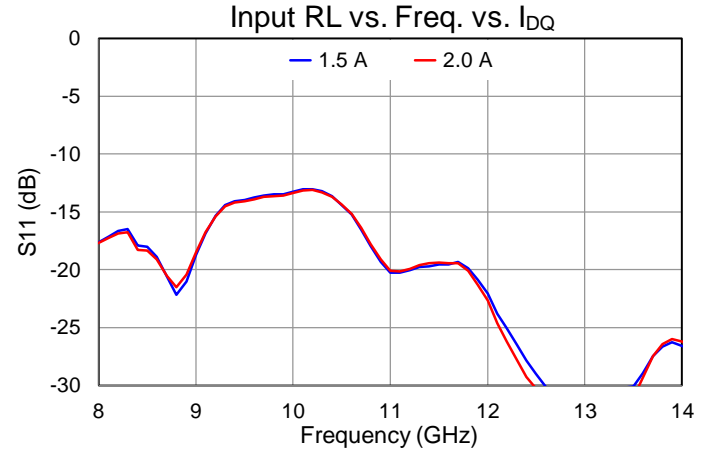
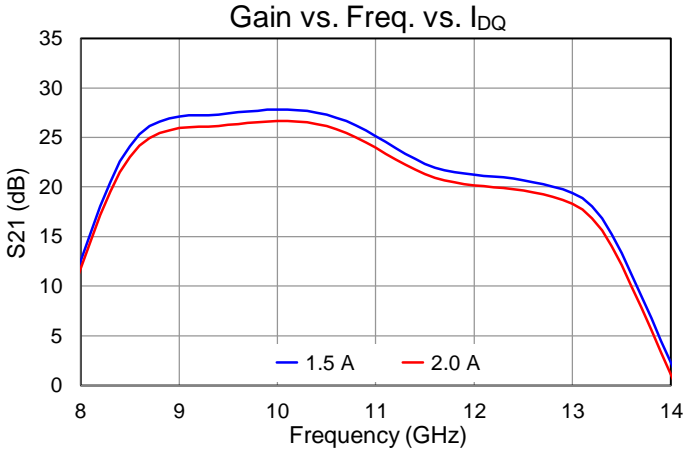

Thermal and Reliability Information

Parameter	Test Conditions	Value	Units
Thermal Resistance (θ_{JC}) ⁽¹⁾	$T_{BASE} = 85^{\circ}\text{C}$, $V_D = +28\text{ V}$, $I_{DQ} = 2.0\text{ A}$, $P_{DISS} = 56\text{ W}$	0.200	$^{\circ}\text{C}/\text{W}$
Channel Temperature, T_{CH} (No RF)		96.1	$^{\circ}\text{C}$
Thermal Resistance (θ_{JC}) ⁽¹⁾	$T_{BASE} = 85^{\circ}\text{C}$, $V_D = +28\text{ V}$, Freq = 12 GHz, $P_{IN} = 28\text{ dBm}$, $I_{DQ} = 2.0\text{ A}$, $I_{D_Drive} = 12.3\text{ A}$, $P_{OUT} = 48.8\text{ dBm}$, $P_{DISS} = 271.3\text{ W}$	0.226	$^{\circ}\text{C}/\text{W}$
Channel Temperature, T_{CH} (Under RF)		146.3	$^{\circ}\text{C}$
Thermal Resistance (θ_{JC}) ⁽¹⁾	$T_{BASE} = 85^{\circ}\text{C}$, $V_D = +28\text{ V}$, Freq = 12 GHz, $P_{IN} = 32\text{ dBm}$, $I_{DQ} = 2.0\text{ A}$, $I_{D_Drive} = 15.6\text{ A}$, $P_{OUT} = 50.1\text{ dBm}$, $P_{DISS} = 333.2\text{ W}$	0.249	$^{\circ}\text{C}/\text{W}$
Channel Temperature, T_{CH} (Under RF)		168.0	$^{\circ}\text{C}$

Notes:

1. Thermal resistance measured to back of package ($T = 85^{\circ}\text{C}$).
2. Refer to the following document: [GaN Device Channel Temperature, Thermal Resistance, and Reliability Estimates](#)

Gate Current and Dissipated Power

Test conditions unless otherwise noted: $T = 85^{\circ}\text{C}$, $I_{DQ} = 2.0\text{ A}$, $P_{IN} = 28\text{ dBm}$, $PW = 150\text{ us}$, Duty Cycle = 20%

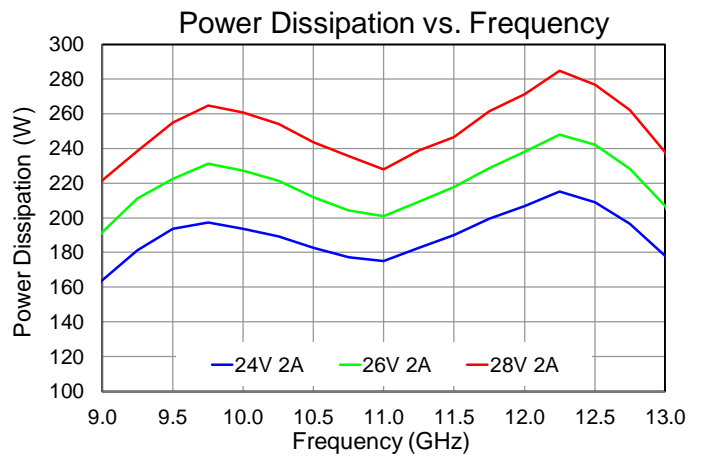
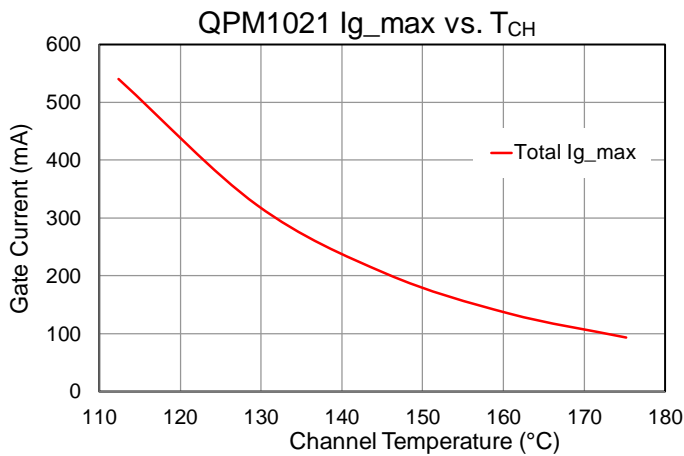

Applications Information

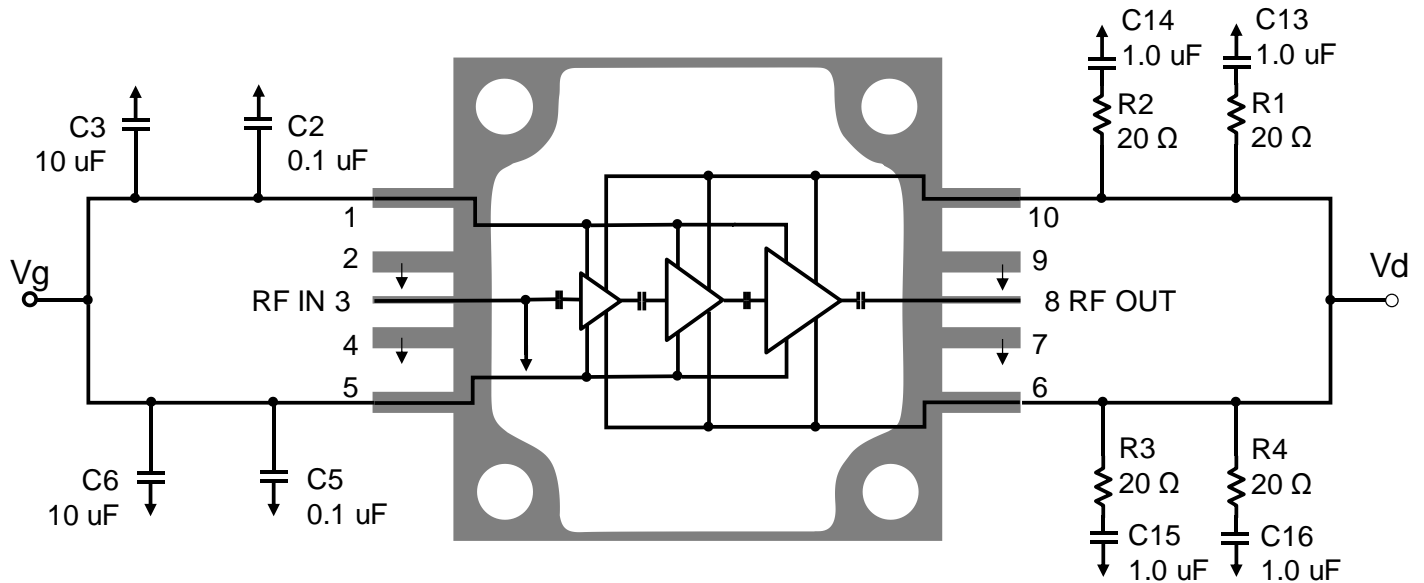

Notes:

1. V_G & V_D need to be biased from both sides.

Bias-Up Procedure

1. Set I_D limit to 17 A (peak), I_G limit to 60 mA
2. Set V_G to -5.0 V
3. Set V_D +28 V
4. Adjust V_G more positive until $I_{DQ} = 2.0$ A, peak
5. Apply RF signal

Bias-Down Procedure

1. Turn off RF signal
2. Reduce V_G to -5.0 V. Ensure $I_{DQ} \sim 0$ mA
4. Set V_D to 0 V
5. Turn off V_D supply
6. Turn off V_G supply

Evaluation Board (EVB) Layout Assembly

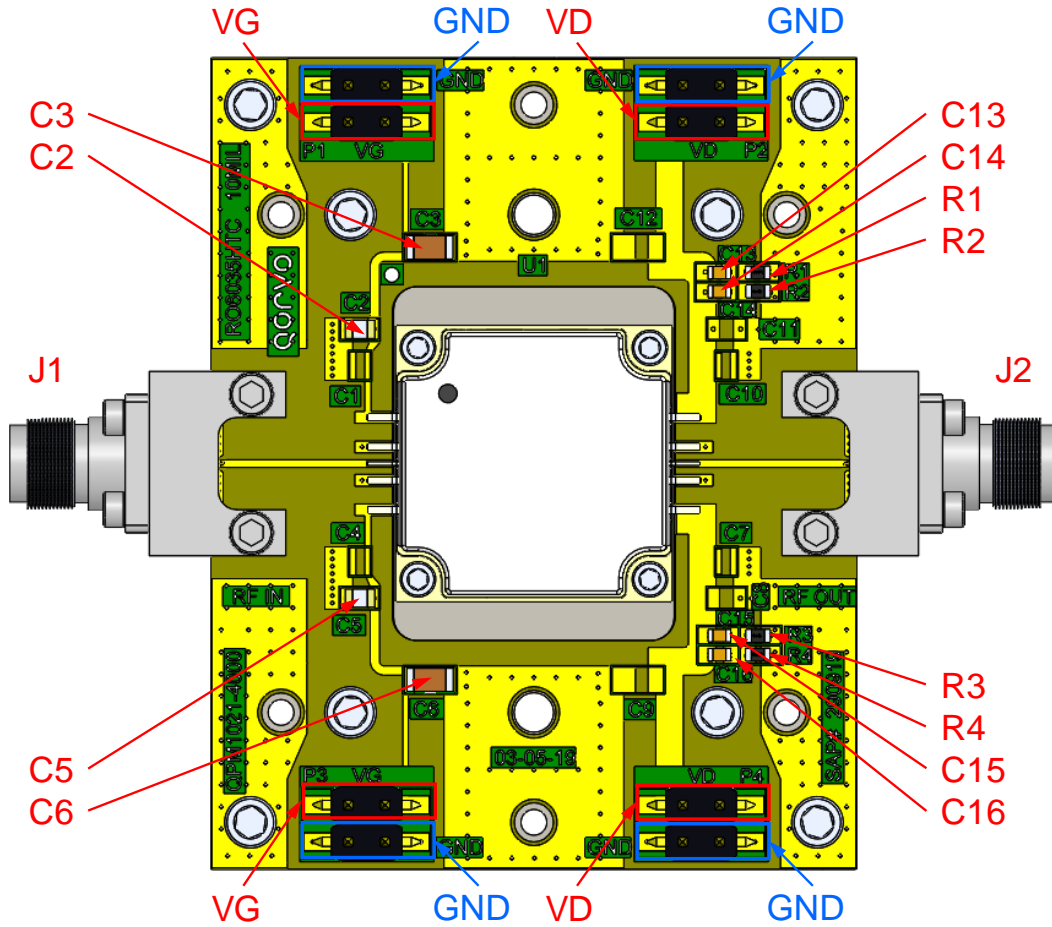

Bill of Materials

Reference Des.	Value	Description	Manuf.	Part Number
C3, C6	10 uF	CAP, CER, 10 uF, 50 V, 20%, X5R, 1206	Various	
C2, C5	0.1 uF	CAP, 0.1uF, 10%, 50V, X7R, 0805	Various	
C13, C14, C15, C16		CAP, 1uF, 10%, 50V, X7R, 0603	Various	
R1, R2, R3, R4	20 Ohm	RES 0603 20Ohms 200mW 1% -55 to +155C	Various	
J1, J2	2.92 mm	Female End Launch Connector	Southwest Microwave	1092-02A-5
PCB	-----	Rogers 6035HTC, 10 mil dielectric, 0.5 oz. copper (gold plated)	Rogers Corp.	

Mechanical Information and Bond Pad Description

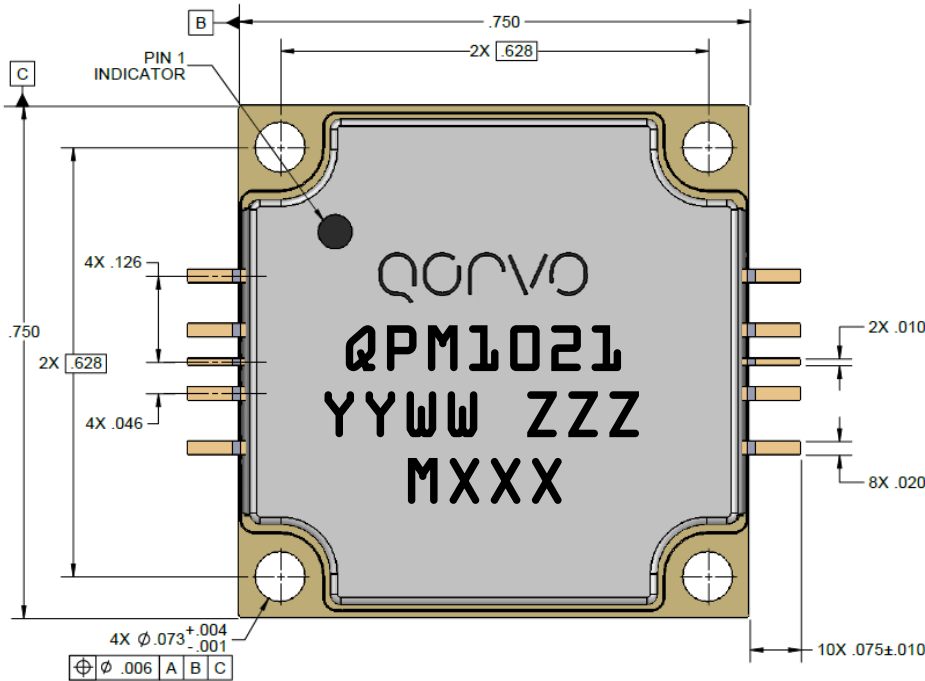

NOTES:

1. MATERIALS

- PACKAGE BASE: COPPER
- FINISH: GOLD
- LEADS: ALLOY 194
- FINISH: GOLD
- LID: LCP (LIQUID CRYSTAL POLYMER)

2. PART IS EPOXY SEALED

3. PART MARKING

- QPM1021 : PART NUMBER
- YY : PART ASSEMBLY YEAR
- WW : PART ASSEMBLY WEEK
- ZZZ : SERIAL NUMBER
- MYYY : BATCH ID

Tolerances are as follows (unless noted):

- .XX = ±.01
- .XXX = ±.005
- .XXXX = ±.0010



Package Lead Description

Pad No.	Symbol	Description
1, 5	V _G	Gate voltage. Bias network is required; see Application Circuit on page 12. Gate must be biased from both sides.
2, 4, 7, 9	Ground	Must be grounded to PCB
3	RF Input	RF Input; matched to 50 Ω, DC blocked, DC grounded
6, 10	V _D	Drain voltage. Bias network is required; see Application Circuit on page 12.
8	RF Output	RF Output; matched to 50 Ω, DC blocked

Assembly Notes

1. Carefully clean the PC board and package leads with alcohol. Allow it to dry fully.
2. To improve the thermal and RF performance, Qorvo recommends attaching a heat sink to the bottom of the PCB and apply thermal compound (Arctic Silver 5 recommended) or a 4 mil indium shim between the heat sink and the package.
3. (The following is for information only. There are many variables in a second level assembly that Qorvo does not control, so Qorvo does not recommend an absolute torque value.) Use screws to attach the component to the heat sink. A suggested final torque value is 16 in-oz. for a 0-80 screw. Start with screws finger tight, then torque to 8 in-oz., then torque to final value. Use the following tightening pattern:

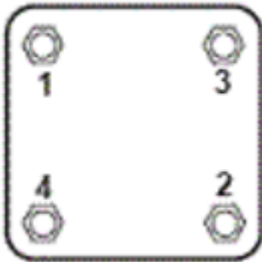

4. Apply no-flux solder to each pin of the QPM1021. The component leads should be manually soldered, and the package should not be subjected to conventional reflow processes. The use of no-clean solder to avoid washing after soldering is recommended.