



# QPQ1040Q

## 2300-2400 MHz TX/RX Filter

### Product Overview

The QPQ1040Q is a high-performance, high power Bulk Acoustic Wave (BAW) TX filter designed to meet the strict LTE/NR rejection requirements for use in B40/n40.

The QPQ1040Q is specifically designed to meet the high performance expectations of insertion loss and rejection for LTE/NR transmit systems under all operating conditions.

The QPQ1040Q uses common module packaging techniques to achieve the industry standard 1.1 x 0.9 x 0.55 mm footprint. The filter exhibits excellent power handling capabilities.

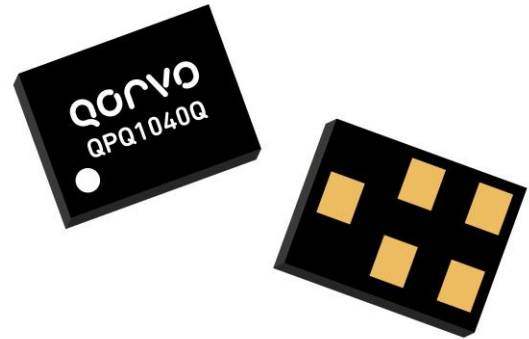

1.1 x 0.9 x 0.55 mm

### Functional Block Diagram

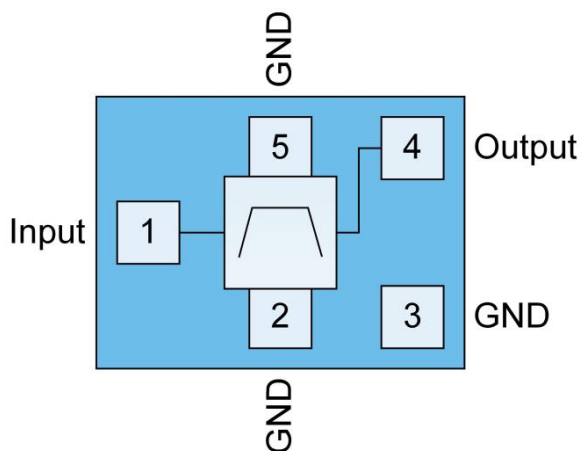

Top View

### Key Features

- Qualified to AEC-Q 200 Grade 3
- Highly selective BAW filter achieving low insertion loss over full bandwidth and operating conditions
- Excellent WiFi Rejection
- RoHS Compliant, Pb-free Module Package

### Applications

- LTE Telematics Modules
- For Band 40 TD-LTE applications

### Ordering Information

Part Number	Description
QPQ1040QEVB	Evaluation Board
QPQ1040QSB	5pc sample bag
QPQ1040QSR	100pcs on 7" reel
QPQ1040QTR13	15,000pcs on 13" reel

# QPQ1040Q

## 2300-2400 MHz TX/RX Filter

### Absolute Maximum Ratings

Parameter	Conditions	Rating
Storage Temperature		-40 to +150°C
Peak RF Input Power (Pin 1)	CW, +25 °C, Max duration of 0.2 sec.	+37dBm

Operation of this device outside the parameter ranges given above may cause permanent damage.

### Recommended Operating Conditions

Parameter	Min	Typ.	Max	Units
Operating Ambient Temperature	-40	+25	+85	°C

Electrical specifications are measured at specified test conditions. Specifications are not guaranteed over all recommended operating conditions.

### Minimum Lifetime Ratings

Conditions	Rating
RF Input Signal (Pin 1) 2300-2400 MHz, 40% duty cycle/LTE, QPSK, 5MHz, 25RB, +55 °C, +32.5dBm	5K Hrs

# QPQ1040Q

## 2300-2400 MHz TX/RX Filter

### Electrical Specifications <sup>(1)</sup>

Unless otherwise noted: Operating Temp = -40 to 85°C

Parameter	Conditions	Min.	Typ. <sup>(2)</sup>	Max.	Units
Insertion Loss <sup>(3)</sup>	2300 – 2395 MHz		1.0	2.0	dB
	2395 – 2400 MHz		1.4	2.5	
VSWR (ANT)	2300 – 2400 MHz		1.7	2.1	Ratio
VSWR (TX)	2300 – 2400 MHz		1.6	2.1	
Passband Ripple Over 5MHz Channel	2300 – 2400 MHz		0.2	0.8	dB
Attenuation	10 – 1574 MHz	30	35		dB
	1574 – 1577 MHz	30	36		
	1577 – 1680 MHz	30	36		
	1710 – 1785 MHz	30	36		
	1805 – 2170 MHz	31	37		
	2110 – 2170 MHz	37	46		
	2423 – 2441 MHz <sup>(4)</sup>	13	35		
	2428 – 2446 MHz <sup>(4)</sup>	24	44		
	2433 – 2481 MHz <sup>(4)</sup>	40	48		
	2460 – 2500 MHz	41	50		
4600 – 4800 MHz	34	41			
6900 – 7200 MHz	26	33			

Notes:

1. All specifications are based on the applications circuit and Min/max is specified over -40 °C to +85 °C unless otherwise noted.
2. Typical values are based on average measurement at 25°C
3. Data is averaged over the specified frequency
4. Integrated over each 18MHz channel

**QPQ1040Q Application Circuit**

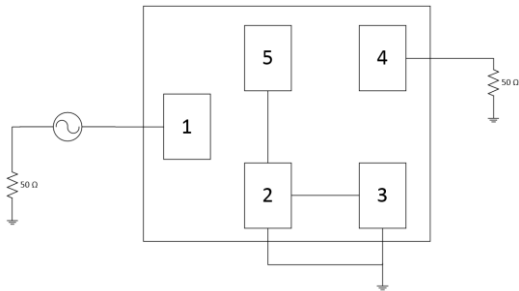

RF ports are internally matched to 50Ω

**QPQ1040Q EVB PCB Information**

Layer	Name	Material	Thickness	Constant	Board Layer Stack
	Top Overlay				
	Top Solder	Solder Resist	0.40mil	3.5	
1	Top Layer	Copper	0.70mil		
	Dielectric1	Taconic TLY-5A	7.50mil	2.4	
2	Signal Layer 1	Copper	0.70mil		
	Dielectric 3	FR-4	52.00mil	4.2	
3	Bottom Layer	Copper	0.70mil		
	Bottom Solder	Solder Resist	0.40mil	3.5	
	Bottom Overlay				

Total Thickness: 62mil

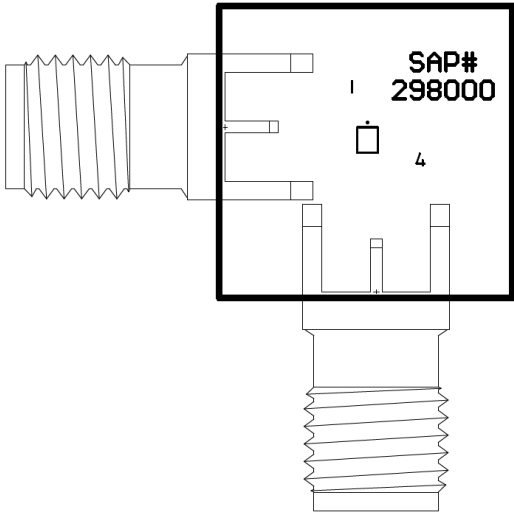

**QPQ1040Q Bill of Material**

Ref. Des.	Value	Description	Manuf.	Part number
PCB	N/A	3 layer	Multiple	
U1	N/A	2300-2400 MHz TX/RX Filter	Qorvo	QPQ1040Q
SMA	N/A	SMA connector	Radiall USA Inc.	9602-1111-018

### Performance Plots

Test conditions unless otherwise noted: Temp. = +25°C

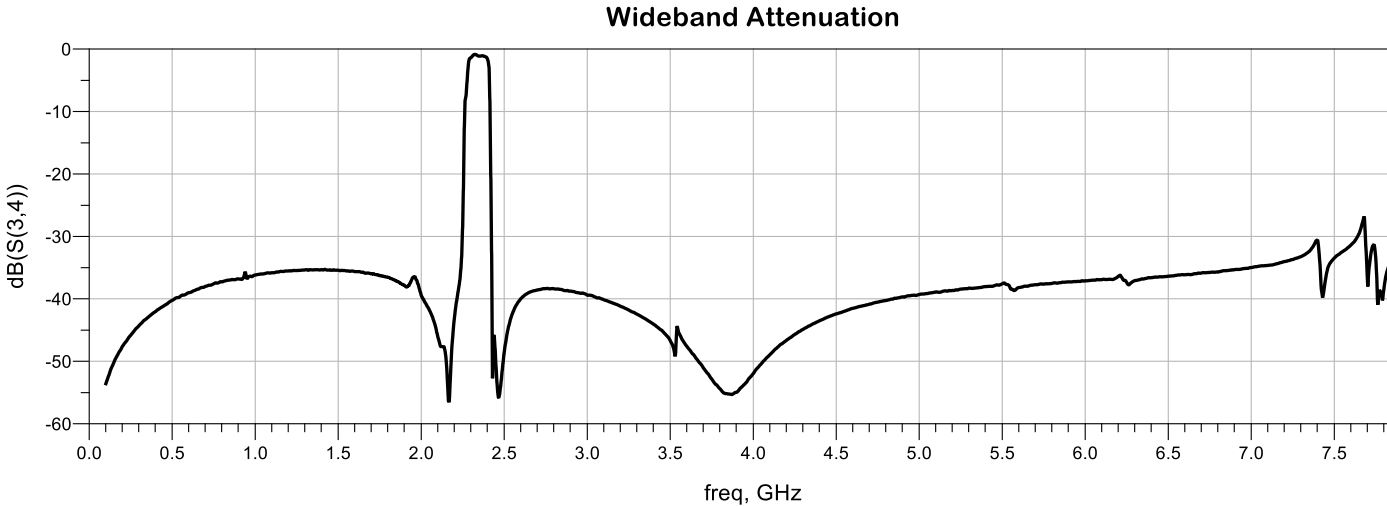
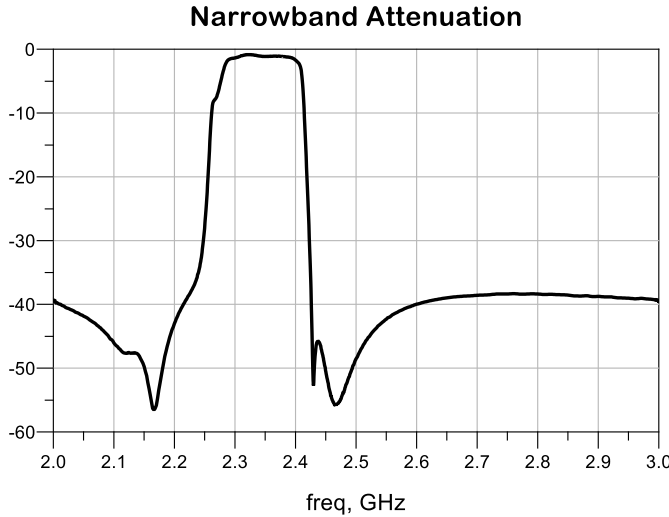

Performance Plots (cont'd)

Test conditions unless otherwise noted: Temp. = +25°C

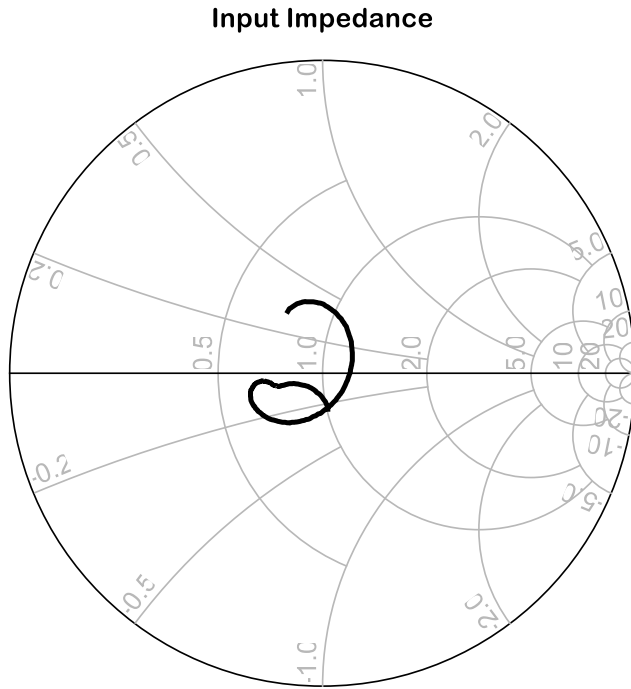
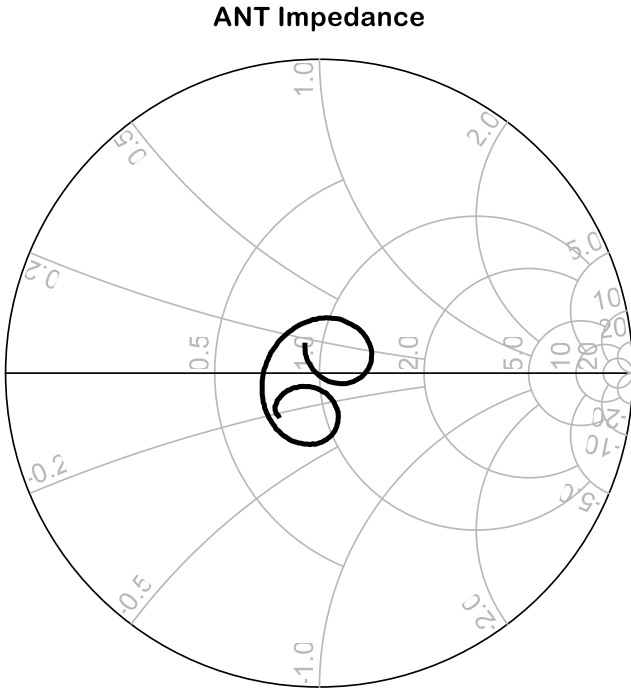
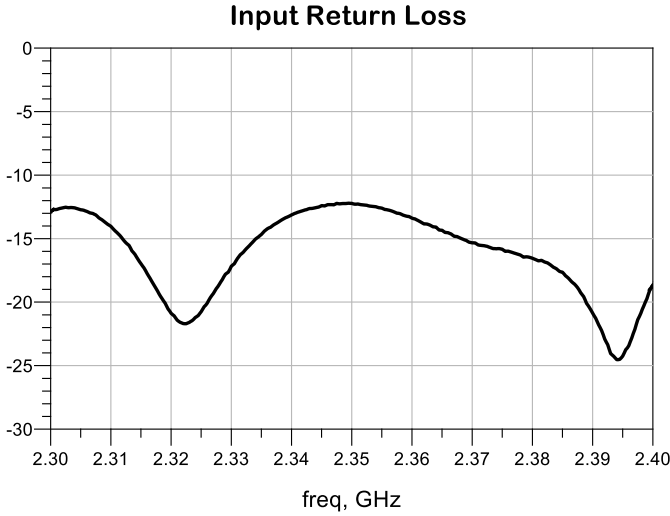
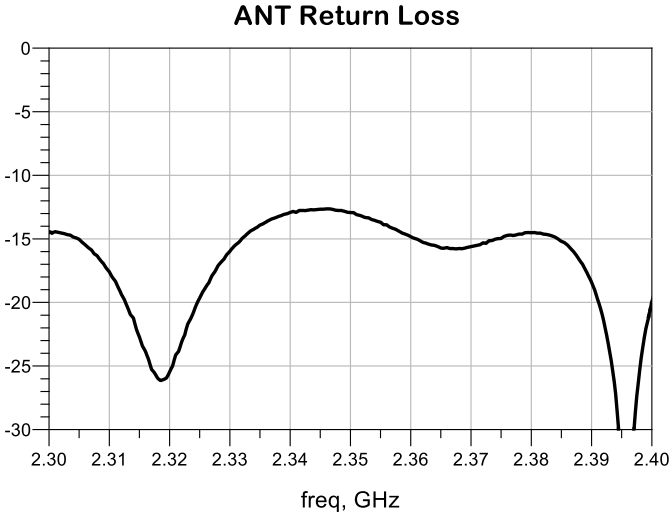

Pin Configuration and Description

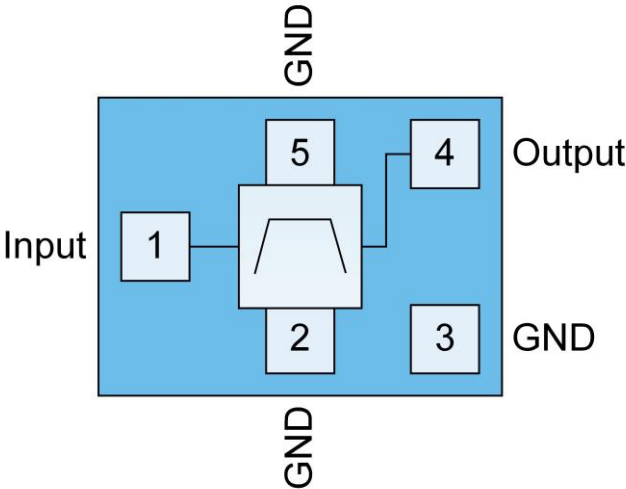

Top View

Pin Number	Label	Description
1	Input	B40 TX Input
4	Output	B40 Ant
2,3,5	Ground	Ground

Marking Diagram

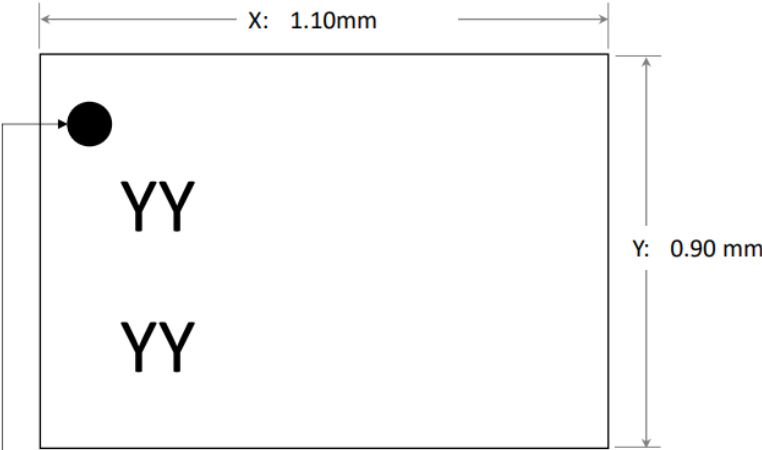

Pin 1 Indicator  
 Trace Code to be assigned by SubCon  
 Logo: Use : No Logo  
 (Where YYYY Indicates Trace Code)

**QPQ1040Q**  
**2300-2400 MHz TX/RX Filter**

**Package Marking and Dimensions**

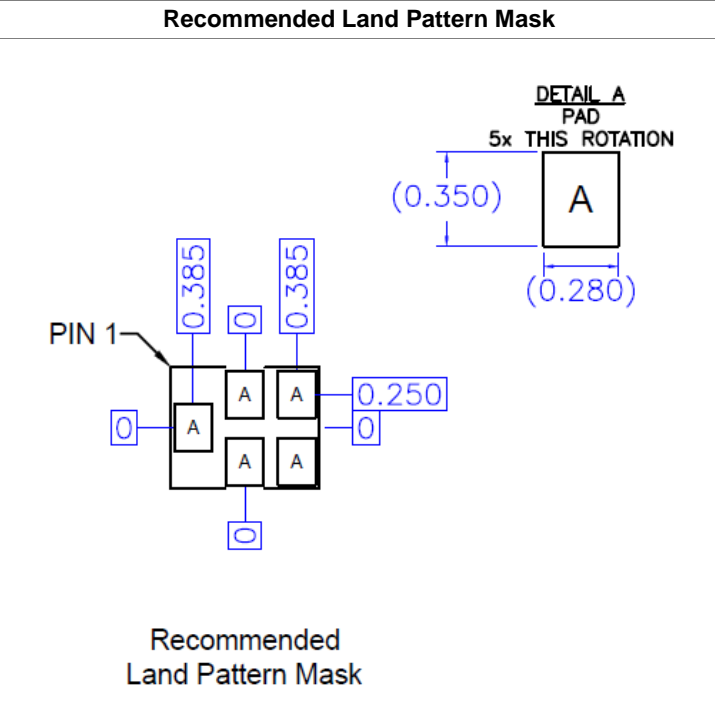
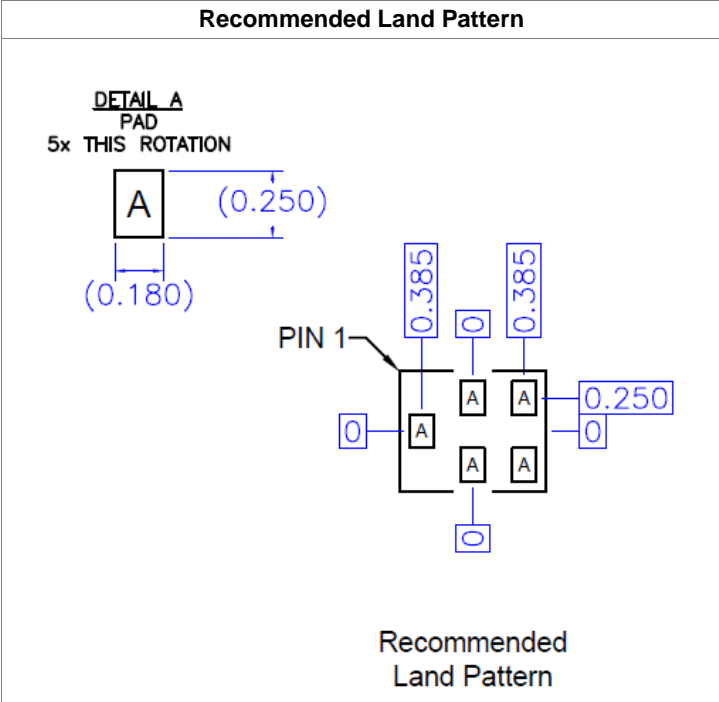
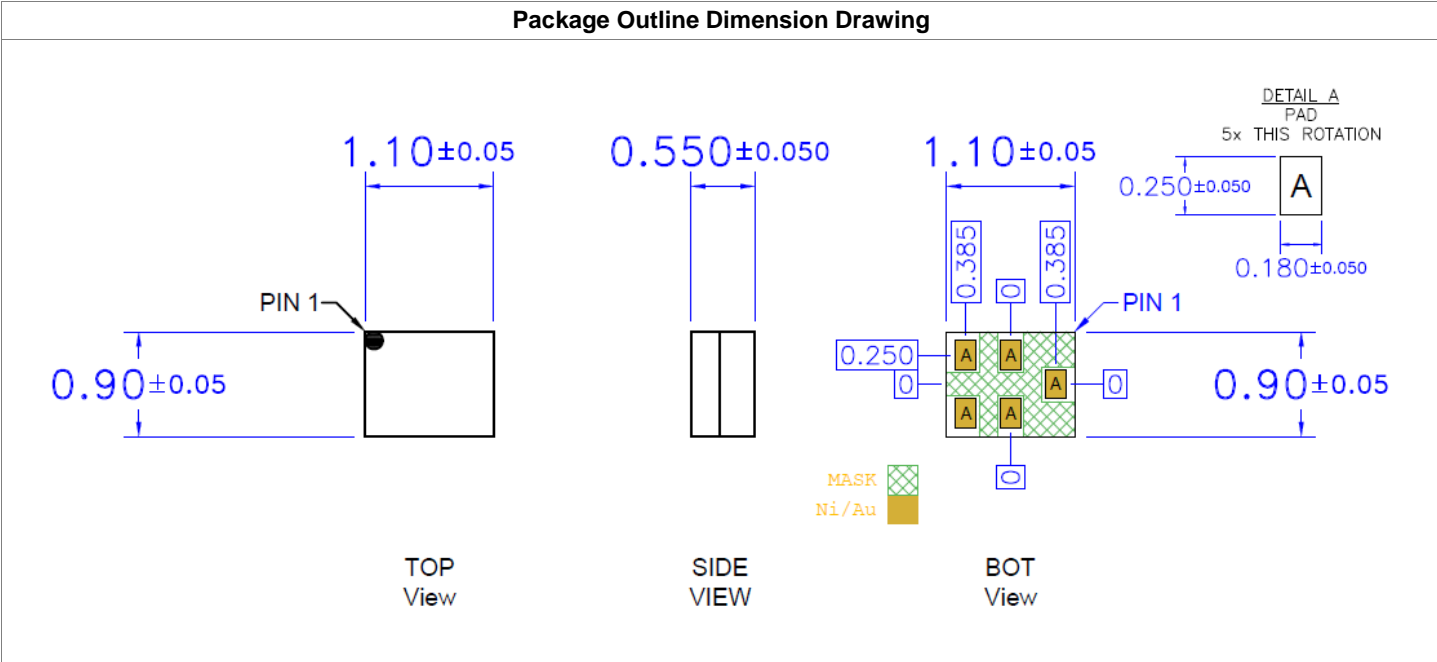

**Notes:**

1. All dimensions are in millimeters. Angles are in degrees.
2. Dimension and tolerance formats conform to ASME Y14.4M-1994.

The terminal #1 identifier and terminal numbering conform to JESD 95-1 SPP-012



# QPQ1040Q 2300-2400 MHz TX/RX Filter

## Tape and Reel Information

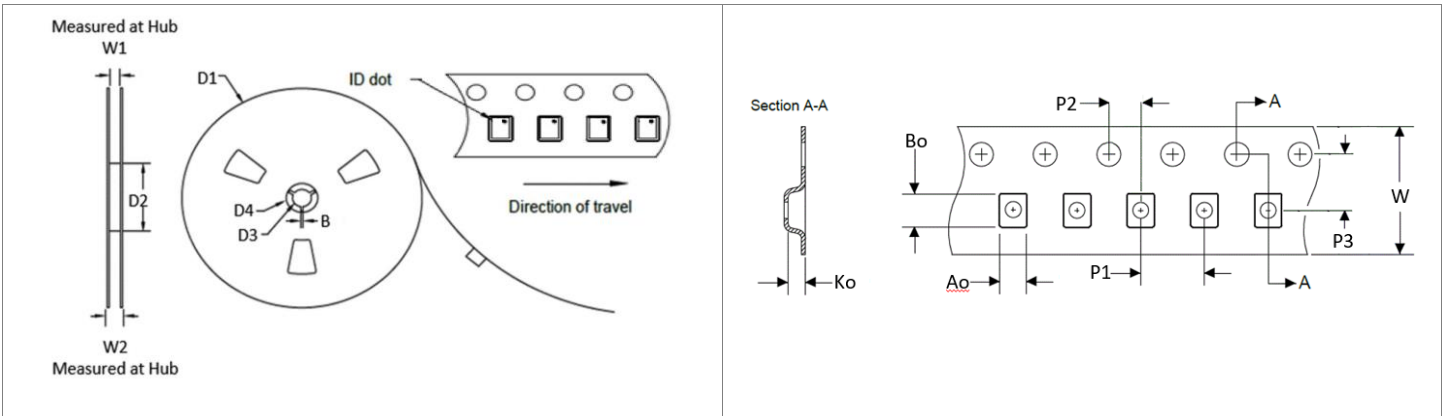

Feature	Measure	Symbol	Size (mm)
Flange	Diameter	D1	330.0
	Thickness	W2	14.2
	Space Between Flange	W1	8.8
Hub	Outer Diameter	D2	102.0
	Arbor Hole Diameter	D3	13.0
	Key Slit Width	B	2.0
	Key Slit Diameter	D4	20.2

Feature	Measure	Symbol	Size (mm)
Cavity	Length	Ao	1.10
	Width	Bo	1.30
	Depth	Ko	0.72
	Pitch	P1	4.0
Centerline Distance	Cavity to Perforation (Length)	P2	2.0
	Cavity to Perforation (Width)	P3	3.5
Carrier Tape	Width	W	8.0

(Unless otherwise specified, all dimension tolerances per EIA-481)

## Handling Precautions

Parameter	Rating	Standard
ESD – Human Body Model (HBM)	Class 1C	ESDA/JEDEC JS-001
ESD – Charged Device Model (CDM)	Class C3	ESDA/JEDEC JS-002
MSL – Moisture Sensitivity Level	MSL3	IPC/JEDEC J-STD-020



Caution!

ESD sensitive device

## Solderability

Compatible with the latest version of J-STD-020, lead free solder, 260°C.

## RoHS Compliance

This part is compliant with the 2011/65/EU RoHS directive (Restrictions on the Use of Certain Hazardous Substances in Electrical and Electronic Equipment), as amended by Directive 2015/863/EU.

This product also has the following attributes:

- Lead Free
- Halogen Free (Chlorine, Bromine)
- Antimony Free
- TBBP-A (C<sub>15</sub>H<sub>12</sub>Br<sub>4</sub>O<sub>2</sub>) Free
- PFOS-Free
- SVHC Free