

### Product Description

The QPQ1041Q is a high-performance Tx/Rx filter designed to meet the full B41 Wide Coverage (2496MHz – 2690MHz) performance requirements.

QPQ1041Q is specifically designed to meet the high performance expectations of insertion loss and rejection for TD-LTE and NR systems under all operating conditions to enable best overall system level performance.

The QPQ1041Q uses common module packaging techniques to achieve the industry standard 1.4 x 1.1 x 0.55 mm footprint. The filter exhibits excellent power handling capabilities.

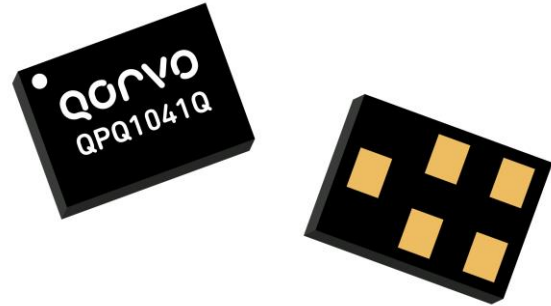

1.4 x 1.1 x 0.55 mm

### Functional Block Diagram

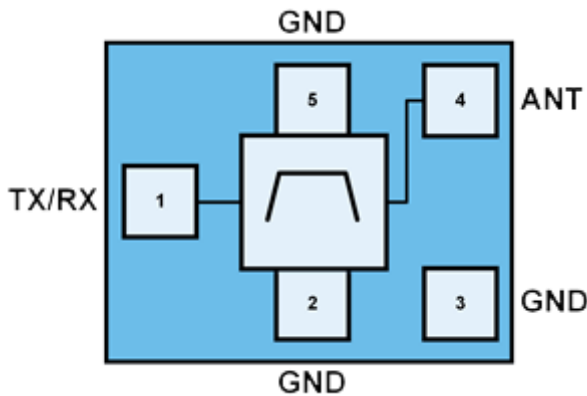

Top View

### Feature Overview

- Qualified to AEC-Q 200 Grade 3
- Industry leading small size: 1.4 x 1.1 x 0.55mm
- Single-Ended operation
- B41 and 5G n41 capable
- RoHS Compliant, Pb-free module package

### Applications

- LTE Telematics Units
- Power Class 2 Compliant

### Ordering Information

PART NUMBER	DESCRIPTION
QPQ1041QEVB	Evaluation Board
QPQ1041QSB	5pc sample bag
QPQ1041QSR	100pcs on 7" reel
QPQ1041QTR13	15,000pcs on 13" reel

## Absolute Maximum Ratings

PARAMETER	RANGE/VALUE	UNITS
Storage Temperature	-40 to +150	°C
Peak RF Input Power (pin 1) CW Signal, Max duration of 0.2 sec	+34.5	dBm

Operation of this device outside the parameter ranges given above may cause permanent damage.

## Recommended Operating Conditions

PARAMETER	MIN	TYP	MAX	UNITS
Operating Ambient Temperature	-40		+85	°C

## Minimum Lifetime Ratings

Conditions	Rating
RF Input Power (pin 1) TD-LTE, 5MHz BW, 1RB, 24RB Offset, +55C, 32.0dBm	5K Hrs

## Electrical Specifications<sup>(1)</sup>

Unless otherwise noted: Operating Temp. = -40 °C to +85 °C.

PARAMETER	CONDITIONS	MIN	TYP. <sup>(2)</sup>	MAX.	UNITS
Insertion Loss <sup>(3)</sup>	2496 MHz – 2500 MHz		2.5	3.7	dB
	2500 MHz – 2515 MHz		2.1	3.1	
	2515 MHz – 2545 MHz		1.8	2.8	
	2545 MHz – 2575 MHz		1.7	2.5	
	2575 MHz – 2675 MHz		1.6	2.2	
	2675 MHz – 2690 MHz		1.8	3.0	
VSWR (TX)	2496 MHz – 2590 MHz		1.7	2.2	Ratio
	2591 MHz – 2690 MHz		1.8	2.3	
	2515 MHz – 2590 MHz		1.7	2.2	
	2591 MHz – 2675 MHz		1.8	2.3	
VSWR (ANT)	2496 MHz – 2590 MHz		1.6	2.2	Ratio
	2591 MHz – 2690 MHz		1.8	2.3	
	2515 MHz – 2590 MHz		1.6	2.2	
	2591 MHz – 2675 MHz		1.8	2.3	
Attenuation	617 MHz – 960 MHz	40	52		dB
	1166.22 MHz – 1254 MHz	41	58		
	1559.052 MHz – 1605.89 MHz	39	65		
	1710 MHz – 1785 MHz	36	52		
	1805 MHz – 1880 MHz	27	47		
	1880 MHz – 1920 MHz	30	44		
	1920 MHz – 1990 MHz	32	41		
	2010 MHz – 2025 MHz	32	40		
	2110 MHz – 2170 MHz	31	36		
	2300 MHz – 2400 MHz	10	32		
	2403 MHz – 2421 MHz <sup>(4)</sup> (WiFi CH1)	27	41		
	2408 MHz – 2426 MHz <sup>(4)</sup> (WiFi CH2)	27	42		
	2413 MHz – 2431 MHz <sup>(4)</sup> (WiFi CH3)	28	44		
	2418 MHz – 2456 MHz <sup>(4)</sup> (WiFi CH4 - 8)	29	46		
	2443 MHz – 2461 MHz <sup>(4)</sup> (WiFi CH9)	30	48		
	2448 MHz – 2466 MHz <sup>(4)</sup> (WiFi CH10)	26	43		
	2453 MHz – 2471 MHz <sup>(4)</sup> (WiFi CH11)	22	40		
2458 MHz – 2476 MHz <sup>(4)</sup> (WiFi CH12)	17	33			
2463 MHz – 2481 MHz <sup>(4)</sup> (WiFi CH13)	7	22			

Notes:

1. All specifications are based on the QPQ1041Q Applications Circuit
2. Typical Values are based on average measurement at 25°C
3. Data is averaged over the specified frequency range
4. Integrated over each 18MHz channel

## QPQ1041Q-EVB PCB Information

### Evaluation Board Layer Description/Stackup

Layer	Name	Material	Thickness	Constant	Board Layer Stack
1	Top Overlay				
2	Top Solder	Solder Resist	0.40mil	3.5	
3	Top Layer	Copper	0.70mil		
4	Dielectric1	TACONIC TLY-5A	7.50mil	2.17	
5	Signal Layer 1	Copper	0.70mil		
6	Dielectric 2	FR4	51.00mil	4.2	
7	Bottom Layer	Copper	0.70mil		
8	Bottom Solder	Solder Resist	0.40mil	3.5	
9	Bottom Overlay				

Total Thickness: 62mils +/- 4mils

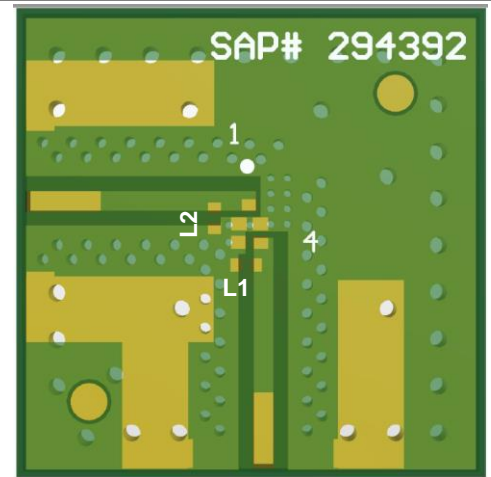

## QPQ1041Q Applications Schematic

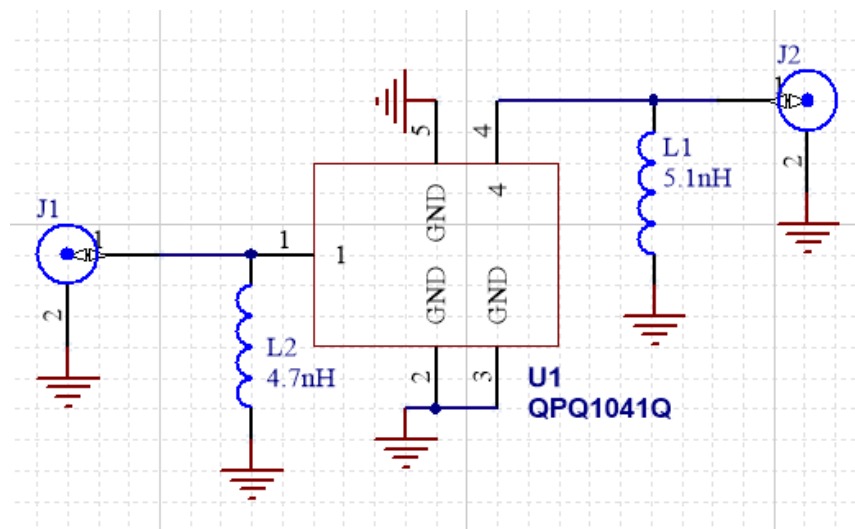

## QPQ1041Q-EVB Bill of Material

REF. DES.	VALUE	DESCRIPTION	MANUF.	PART NUMBER
PCB	N/A	PCB, QPQ1041Q	Multiple	294392
U1	N/A	B41W Tx/Rx Filter	Qorvo	QPQ1041Q
L2	4.7nH	Inductor, 0201, 3%, ULTRA-Q, 0201	Multiple	Ideal
L1	5.1nH	Inductor, 0201, 3%, ULTRA-Q, 0201	Multiple	Ideal
J1, J2	N/A	JACK RCPTCL, END LAUNCH	RADIALL	9602-1111-018

B41 Insertion Loss and Attenuation

Test conditions unless otherwise noted: Temp. = +25 °C

Passband

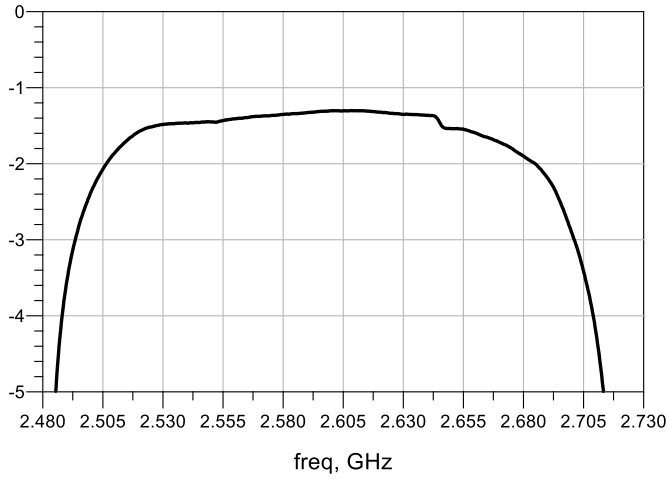

Narrowband

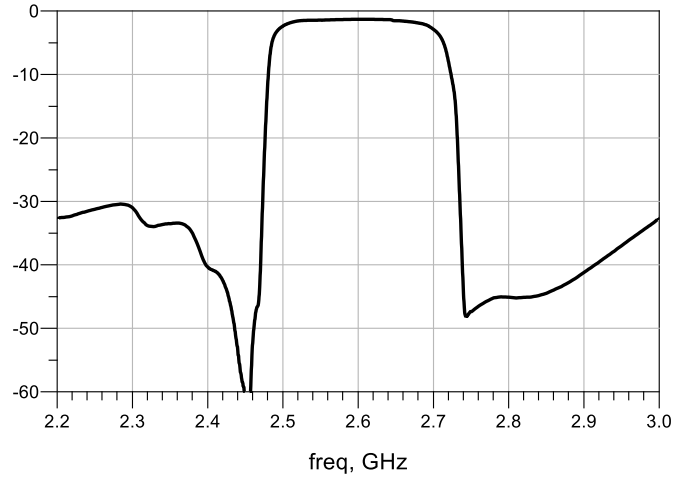

Wi-Fi Attenuation

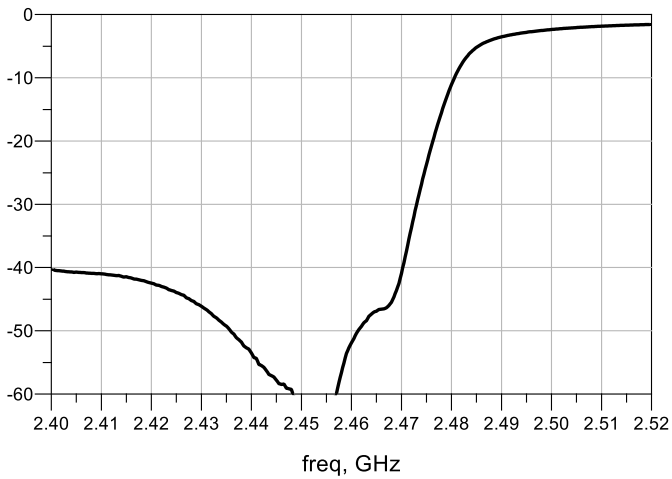

Wideband

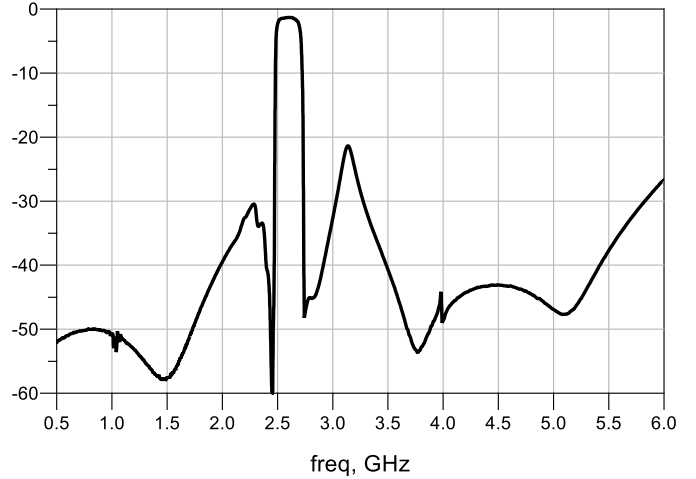

**B41 Return Loss and Impedance**

Test conditions unless otherwise noted: Temp. = +25 °C

Return Loss at ANT

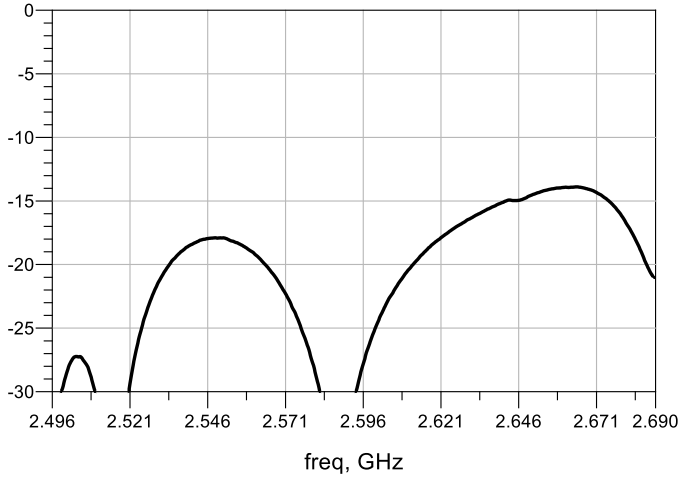

Impedance at ANT

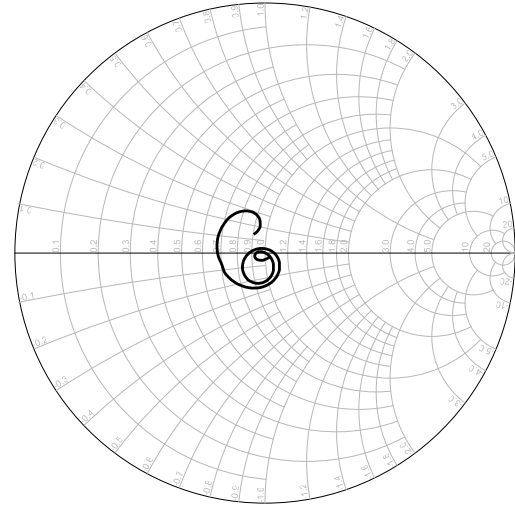

freq (2.496GHz to 2.690GHz)

Return Loss at TRX

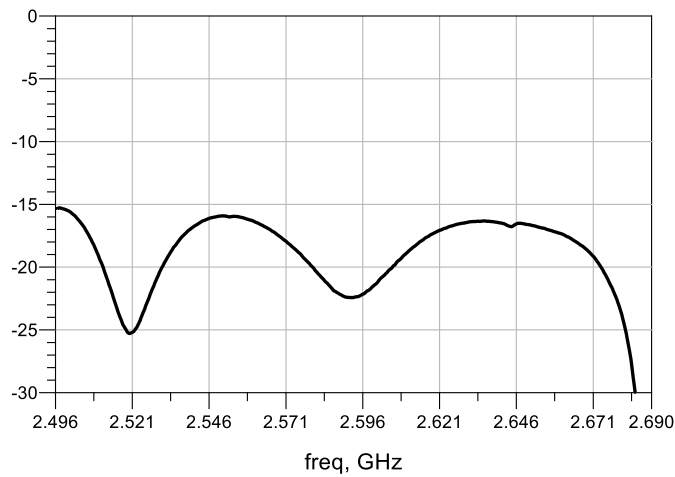

Impedance at TRX

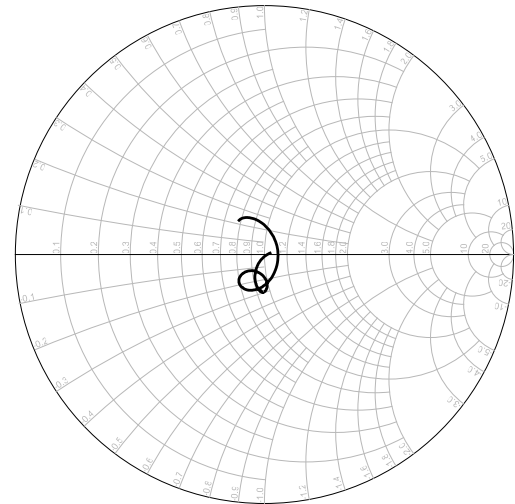

freq (2.496GHz to 2.690GHz)

Pin Configuration and Description

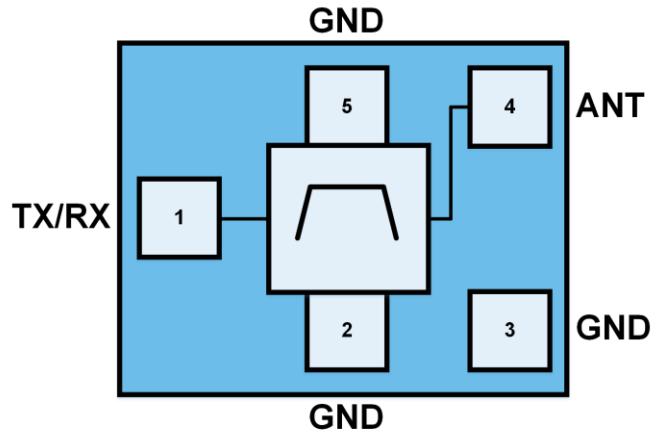

Top View

PIN NUMBER	LABEL	DESCRIPTION
1	TX/RX	Transmit/Receive Port
4	ANT	Antenna Port
2, 3, and 5	GND	Ground

Marking Diagram

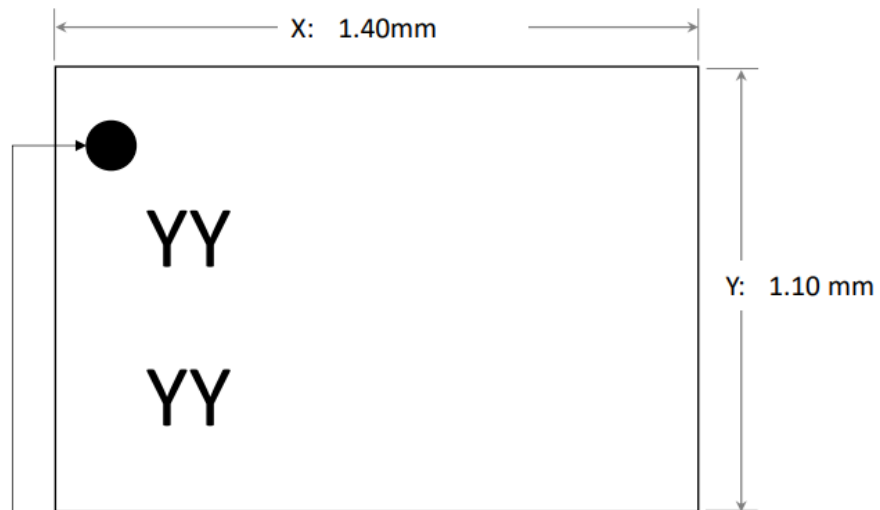

Pin 1 Indicator  
Trace Code to be assigned by SubCon  
Logo: Use : No Logo

(Where YYYY Indicates Trace Code)

Package Marking and Dimensions

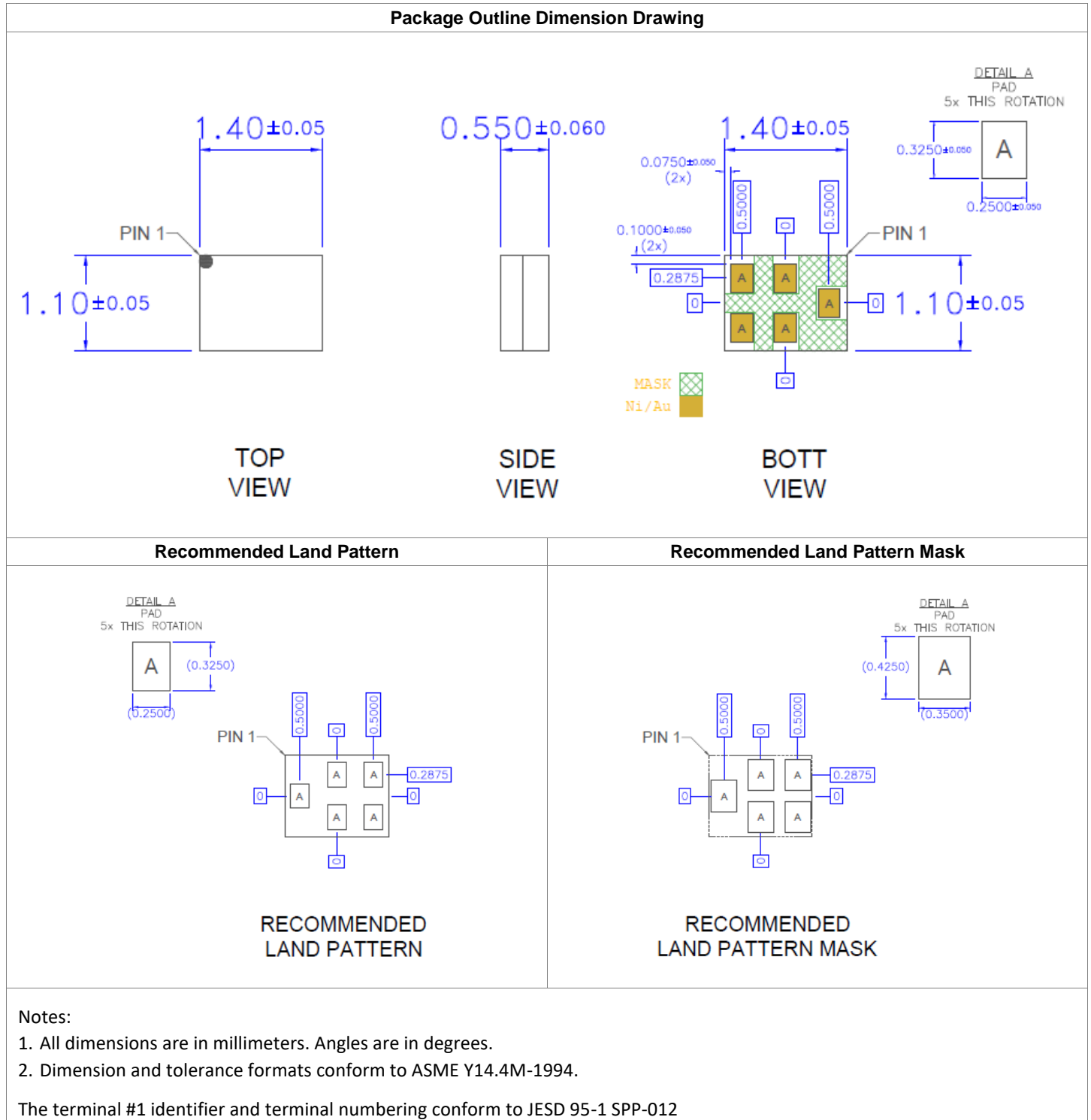



Mechanical Information

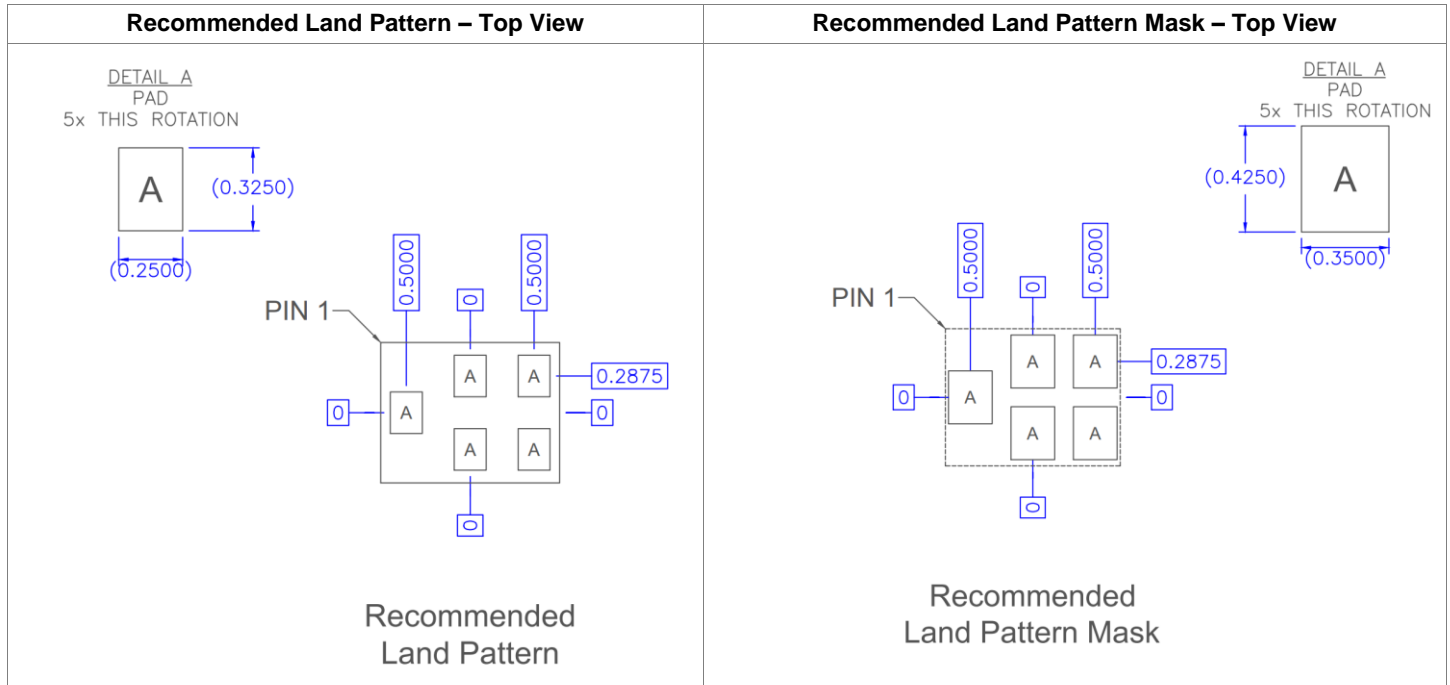

Tape and Reel Information

Feature	Measure	Symbol	Size (mm)
Flange	Diameter	D1	330.0
	Thickness	W2	14.2
	Space Between Flange	W1	8.8
Hub	Outer Diameter	D2	102.0
	Arbor Hole Diameter	D3	13.0
	Key Slit Width	B	2.0
	Key Slit Diameter	D4	20.2

Feature	Measure	Symbol	Size (mm)
Cavity	Length	Ao	1.3
	Width	Bo	1.6
	Depth	Ko	0.74
	Pitch	P1	4.0
Centerline Distance	Cavity to Perforation (Length)	P2	2.0
	Cavity to Perforation (Width)	P3	3.5
Carrier Tape	Width	W	8.0

(Unless otherwise specified, all dimension tolerances per EIA-481)

## Handling Precautions

PARAMETER	RATING	STANDARD
ESD – Human Body Model (HBM)	Class 1C	ESDA/JEDEC JS-001
ESD – Charged Device Model (CDM)	Class C3	ESDA/JEDEC JS-002
MSL – Moisture Sensitivity Level	MSL3	IPC/JEDEC J-STD-020



Caution!  
ESD sensitive device

## Solderability

Compatible with the latest version of J-STD-020, lead free solder, 260°C

## RoHS Compliance

This part is compliant with the 2011/65/EU RoHS directive (Restrictions on the Use of Certain Hazardous Substances in Electrical and Electronic Equipment), as amended by Directive 2015/863/EU.

- Lead-free
- Halogen Free (Chlorine, Bromine)
- Antimony Free
- TBBP-A (C<sub>15</sub>H<sub>12</sub>Br<sub>4</sub>O<sub>2</sub>) Free
- PFOS Free
- SVHC Free

