



QPQ1905

Wi-Fi/IoT bandBoost Filter

Product Overview

The Qorvo® QPQ1905 is an high-performance, high power, Bulk Acoustic Wave (BAW) band-pass filter with extremely steep skirts, simultaneously exhibiting low loss in the Wi-Fi band (Channels 1-2) and high near-in rejection in the 2.4GHz higher frequency channels.

The filter module is specifically designed to enable unique use cases where sub-dividing usable channels within the available Wi-Fi spectrum becomes an advantage. End users will see a capability to deliver Wi-Fi in channels 1 or 2 while providing rejection in higher frequencies to allow simultaneous use of Wi-Fi, Zigbee, Thread or BLE channels.

Using common module packaging techniques to achieve the industry standard footprint while negating as many external passive placements to help end users ease of integration into their circuits

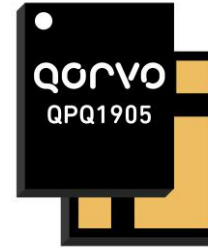

2 Pad 1.6x2.0mm Laminate Package

Key Features

- 2402-2427 MHz
- Low Insertion Loss in Wi-Fi Channels 1-2
- High rejection in the lower band Wi-Fi (CH10-11), Zigbee, Thread or Bluetooth channels. Extended temperature performance from 0 to +90 °C
- High power handling to +28dBm averaged Input Power

Applications

- Access Points
- Wireless Routers
- Residential Gateways
- Customer Premise Equipment
- Internet of Things

Functional Block Diagram

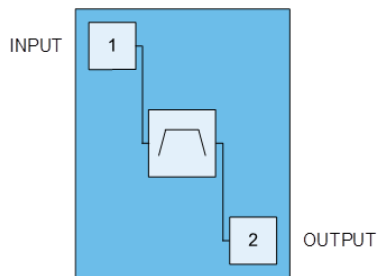

Top View

Ordering Information

Part Number	Description
QPQ1905SB	Sample bag with 5 pieces
QPQ1905SR	7" reel with 100 pieces
QPQ1905TR13	13" reel with 10,000 pieces
QPQ1905EVB-01	Assembled Evaluation Board

Absolute Maximum Ratings

Parameter	Conditions	Rating
Operating Case Temperature	No damage	-40 to 105 °C
Storage Temperature		-40 to 125 °C

Exceeding any one or a combination of the Absolute Maximum Rating conditions may cause permanent damage to the device.

Minimum Lifetime Ratings

Parameter	Conditions	Rating
MTTF >1M hours, +90°C	802.11n MCS0 signal, 10dB PAR, applied to Pin 1	+28 dBm

Recommended Operating Conditions

Parameter	Min.	Typ.	Max.	Units
T _{OPERATING} *	0		+90	°C

Electrical specifications are measured at specified test conditions. Specifications are not guaranteed over all recommended operating conditions. * T_{OPERATING} is temperature at the package ground

Electrical Specifications

Parameter (INPUT-OUTPUT) ⁽¹⁾⁽⁵⁾	Conditions	Min.	Typ.	Max.	Units
Insertion Loss ⁽²⁾	f = 2402.5-2421.5 MHz (CH1)	-	1.0	2.6	dB
	f = 2407.5-2426.5 MHz (CH2)	-	1.1	3.6	dB
Amplitude Variation	f = 2402.5-2421.5 MHz (CH1)	-	0.3	1.0	dB
	f = 2407.5-2426.5 MHz (CH2)	-	0.7	2.0	dB
INPUT VSWR	f = 2402.5-2421.5 MHz (CH1)		1.2:1	1.9:1	
	f = 2407.5-2426.5 MHz (CH2)		1.3:1	1.9:1	
OUTPUT VSWR	f = 2402.5-2421.5 MHz (CH1)		1.2:1	1.9:1	
	f = 2407.5-2426.5 MHz (CH2)		1.3:1	1.9:1	
INPUT Return Loss	f = 2402.5-2421.5 MHz (CH1)		19.6		dB
	f = 2407.5-2426.5 MHz (CH2)		18.7		dB
OUTPUT Return Loss	f = 2402.5-2421.5 MHz (CH1)		21.5		dB
	f = 2407.5-2426.5 MHz (CH2)		19.2		dB
Attenuation	f = 2447.5 – 2466.5 MHz (CH10) ⁽³⁾⁽⁴⁾	49	60	-	dB
	f = 2452.5 – 2471,5 MHz (CH11) ⁽³⁾⁽⁴⁾	48	59	-	dB

Notes:

- 1) All specifications are based on the QPQ1905 Applications Circuit
- 2) Data is the integrated value of the linear s-parameter over 19 MHz channel
- 3) Data is the integrated value of the linear s-parameter over 5 MHz range at the specified temperature
- 4) T = +25 to +65°C
- 5) Pin 1 must be used for input. The large signal performance of this filter, such as power handling, may not be symmetric.

Evaluation Board Schematic

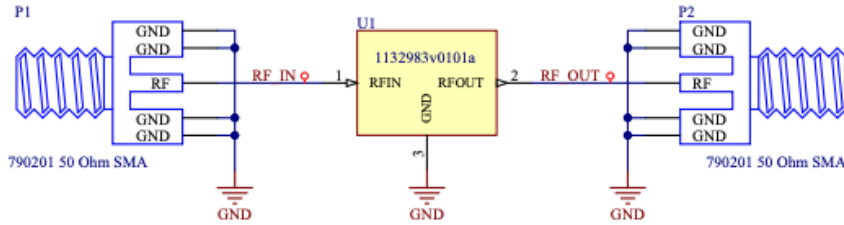

Bill of Material

Ref. Des.	Value	Description	Manuf.	Part number
-	-	Printed Circuit Board		
U1	-	Wi-Fi Bandedge BAW Filter	Qorvo	QPQ1905

Pin Configuration and Description

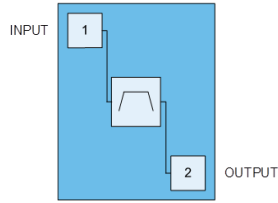

Top View

Pin Number	Label	Description
1	INPUT	RF input. Internally matched to 50 Ω.
2	OUTPUT	RF bi-directional port. Internally matched to 50 Ω
Backside Paddle	-	Ground connection.

Mechanical Information

Dimensions and PCB Mounting Pattern

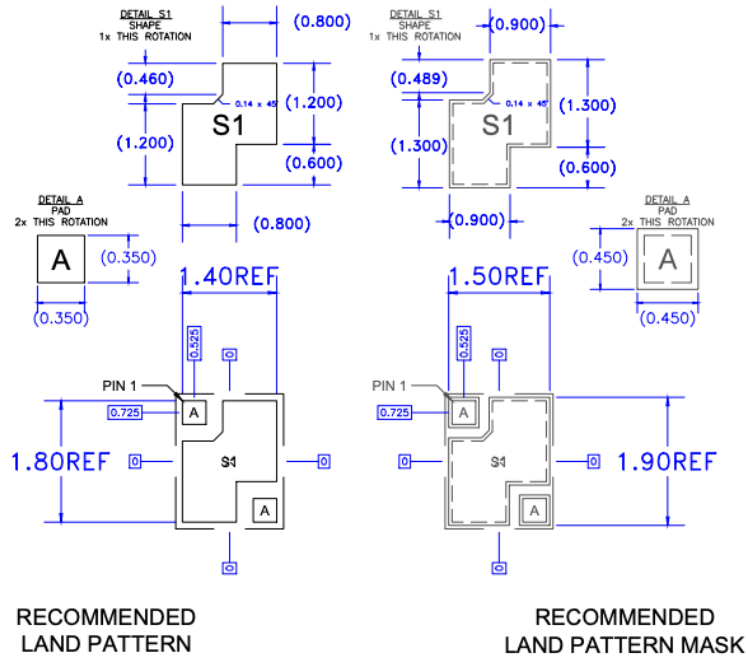
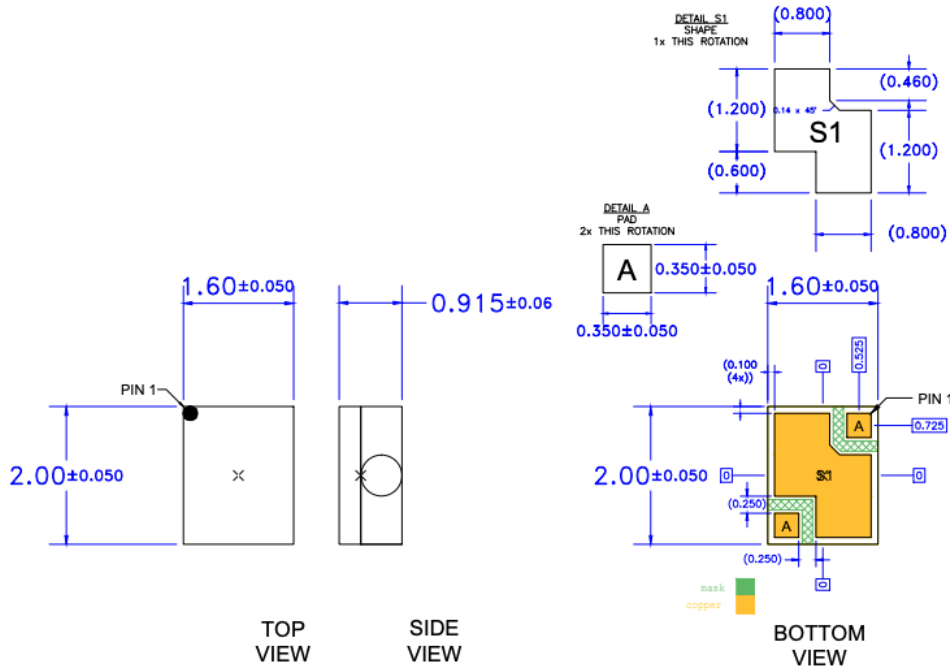

Notes:

1. All dimensions are in millimeters. Angles are in degrees.
2. Dimension and tolerance formats conform to ASME Y14.4M-1994.
3. The terminal #1 identifier and terminal numbering conform to JESD 95-1 SPP-012.