

Product Overview

The QPQ1907 is a high-performance, high power Bulk Acoustic Wave (BAW) band-pass filter with extremely steep skirts, simultaneously exhibiting low loss in the Wi-Fi band and high near-in rejection in the 2.6GHz bands.

QPQ1907 is specifically designed to enable coexistence of Wi-Fi and LTE signals within the same device or in close proximity to one another..

Using common module packaging techniques to achieve the industry standard footprint while negating as many external passive placements to help end users ease of integration into their circuits

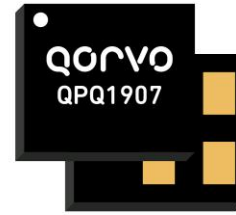

5 Pad 1.4 x 1.2 mm Laminate Package

Key Features

- 2447-2472 MHz
- Low loss in Wi-Fi band with extended upper corner for inclusion of Bluetooth
- High Rejection in LTE bands especially B7/B41
- Extended Temperature performance over -20 to +95 °C
- Self matched to Single Ended 50Ohm operation
- High power handling to +28dBm averaged Input Power

Functional Block Diagram

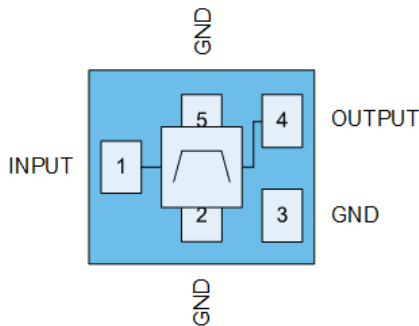

Top View

Applications

- Access Points
- Wireless Routers
- Residential Gateways
- Customer Premise Equipment
- Internet of Things

Ordering Information

| Part Number | Description |
|-----------------|-----------------------------|
| QPQ1907SB | Sample bag with 5 pieces |
| QPQ1907SR | 7" reel with 100 pieces |
| QPQ1907TR13-10K | 13" reel with 10,000 pieces |
| QPQ1907EVB-01 | Assembled Evaluation Board |

Absolute Maximum Ratings

| Parameter | Conditions | Rating |
|----------------------------|------------|---------------|
| Operating Case Temperature | No damage | -40 to 105 °C |
| Storage Temperature | | -40 to 125 °C |

Exceeding any one or a combination of the Absolute Maximum Rating conditions may cause permanent damage to the device.

Minimum Lifetime Ratings

| Parameter | Conditions | Rating |
|-----------------------|--|---------|
| MTTF >1M hours, +95°C | 802.11n MCS7 OFDM signal, 10dB PAR, applied to Pin 1 | +28 dBm |

Recommended Operating Conditions

| Parameter | Min. | Typ. | Max. | Units |
|--------------------------|------|------|------|-------|
| T _{OPERATING} * | -20 | | +95 | °C |

Electrical specifications are measured at specified test conditions. Specifications are not guaranteed over all recommended operating conditions. * T_{OPERATING} is temperature at the package ground

Electrical Specifications

| Parameter (INPUT-OUTPUT) ⁽¹⁾ | Conditions | Min. | Typ. | Max. | Units |
|--|-------------------------------------|------|-------|-------|-------|
| Unless otherwise noted: Typ. T = 35°C | | | | | |
| Insertion Loss ⁽²⁾ | f = 2402.5-2421.5 MHz (CH1) | - | 1.5 | 2.2 | dB |
| | f = 2407.5-2426.5 MHz (CH2) | - | 1.3 | 1.6 | dB |
| | f = 2412.5-2471.5 MHz (CH3-11) | - | 0.8 | 1.3 | dB |
| | f = 2457.5-2476.5 MHz (CH12) | - | 1.0 | 1.5 | dB |
| | f = 2462.5-2481.5 MHz (CH13) | - | 1.4 | 2.2 | dB |
| Amplitude Ripple | f = 2402.5-2421.5 MHz (CH1) | - | 0.7 | 1.5 | dB |
| | f = 2407.5-2426.5 MHz (CH2) | - | 0.4 | 0.7 | dB |
| | f = 2412.5-2471.5 MHz (CH3-11) | - | 0.4 | 1.1 | dB |
| | f = 2457.5-2476.5 MHz (CH12) | - | 0.4 | 0.7 | dB |
| | f = 2462.5-2481.5 MHz (CH13) | - | 0.7 | 1.5 | dB |
| INPUT VSWR | f = 2402.5-2481.5 MHz | | 1.5:1 | 1.8:1 | dB |
| OUTPUT VSWR | f = 2402.5-2481.5 MHz | | 1.5:1 | 2.0:1 | dB |
| Attenuation | f = 925–960 MHz | 34 | 36 | - | dB |
| | f = 1559–1606 MHz | 34 | 46 | - | dB |
| | f = 2110–2170 MHz | 44 | 48 | - | dB |
| | f = 2300–2370 MHz ⁽³⁾ | 38 | 45 | - | dB |
| | f = 2500–2505 MHz ⁽³⁾⁽⁴⁾ | 30 | 39 | - | dB |
| | f = 2500–2505 MHz ⁽³⁾⁽⁵⁾ | 10 | 39 | - | dB |
| | f = 2505–2570 MHz ⁽³⁾⁽⁴⁾ | 43 | 62 | - | dB |
| | f = 2505–2570 MHz ⁽³⁾⁽⁵⁾ | 40 | 62 | - | dB |
| | f = 2570–2620 MHz ⁽³⁾ | 48 | 55 | - | dB |
| f = 2620–2690 MHz ⁽³⁾ | 48 | 52 | - | dB | |

| Parameter | Conditions | Min. | Typ. | Max. | Units |
|-----------|-----------------------------|------|------|------|-------|
| | $f = 4800\text{--}5000$ MHz | 37 | 43 | - | dB |
| | $f = 7200\text{--}7500$ MHz | 7 | 21 | - | dB |

Notes:

- 1) All specifications are based on the QPQ1907 Applications Circuit
- 2) Data is the integrated value of the linear s-parameter over 19 MHz channel
- 3) Data is the integrated value of the linear s-parameter over 5 MHz range at the specified temperature
- 4) T = +25 to +95°C
- 5) T = -20 to +25°C
- 6) Pin 1 must be used for input. The large signal performance of this filter, such as power handling, may not be symmetric.

Performance Plots – QPQ1907EVB-01

Test conditions unless otherwise noted: Temp. = +25 °C

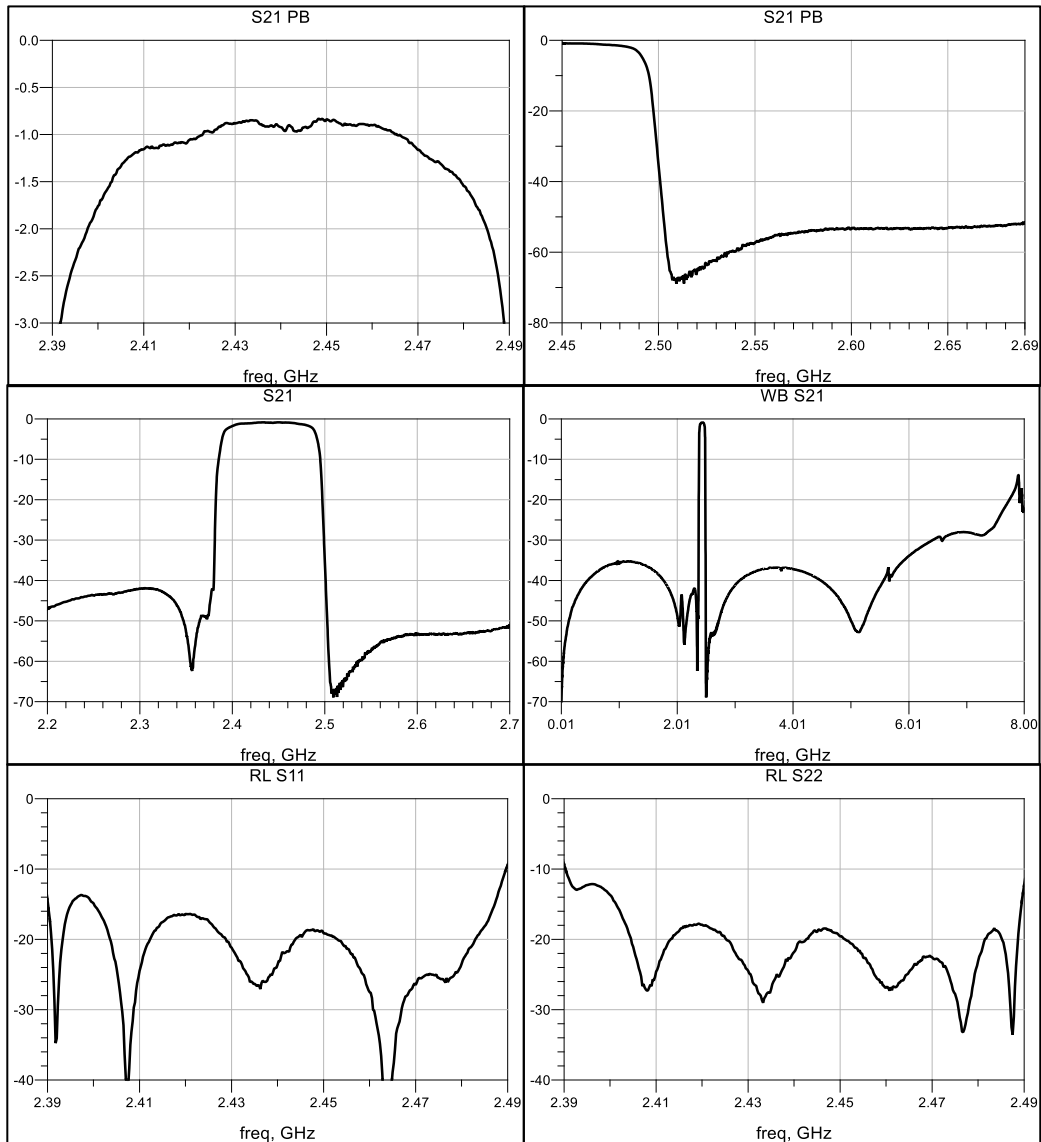

RL S11 Smith Chart

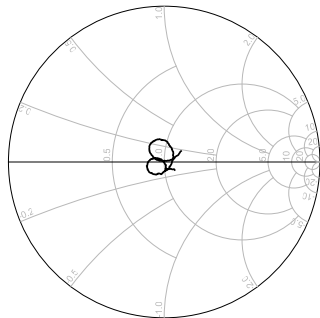

freq (2.402GHz to 2.482GHz)

RL S22 Smith Chart

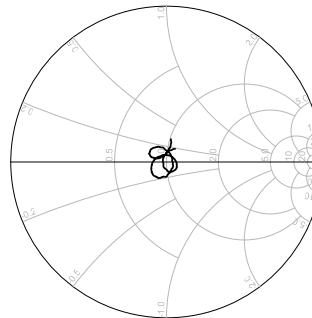

freq (2.402GHz to 2.482GHz)

Evaluation Board



Bill of Material

| Ref. Des. | Value | Description | Manuf. | Part number |
|-----------|-------|--------------------------------|--------|-------------|
| - | - | Printed Circuit Board | | |
| U1 | - | Wi-Fi/LTE coexBoost BAW Filter | Qorvo | QPQ1907 |

Pin Configuration and Description

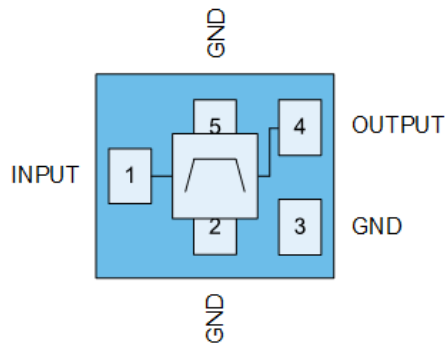

Top View

| Pin Number | Label | Description |
|------------|--------|---|
| 1 | INPUT | RF input. Internally matched to 50 Ω . |
| 2 | GND | Ground connection. |
| 3 | GND | Ground connection. |
| 4 | OUTPUT | RF bi-directional port. Internally matched to 50 Ω |
| 5 | GND | Ground connection. |

Mechanical Information

Dimensions and PCB Mounting Pattern

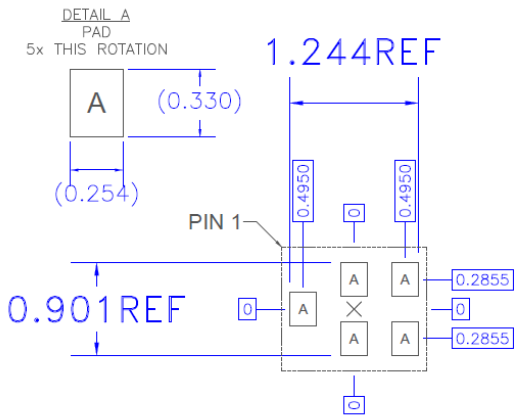
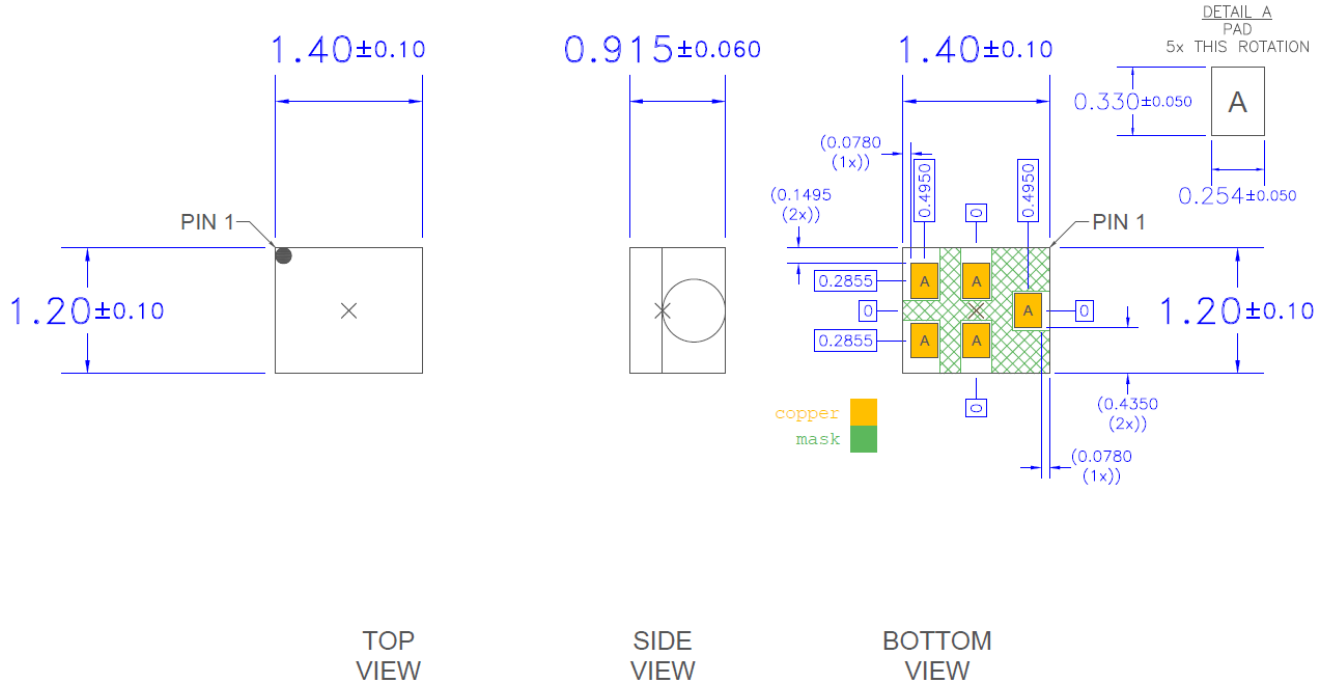

RECOMMENDED
LAND PATTERN

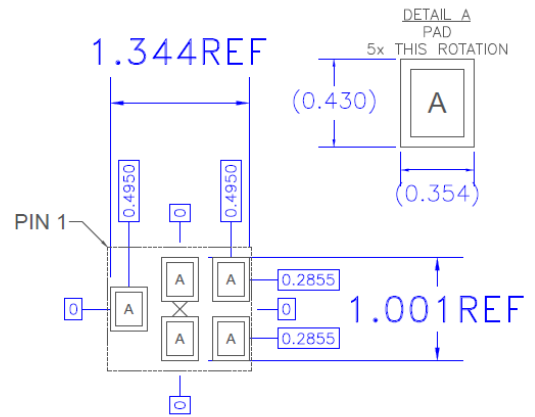

RECOMMENDED
LAND PATTERN MASK

Notes:

1. All dimensions are in millimeters. Angles are in degrees.
2. Dimension and tolerance formats conform to ASME Y14.4M-1994.
3. The terminal #1 identifier and terminal numbering conform to JESD 95-1 SPP-012.