

Product Overview

The QPQ6108 is a high-performance Temperature Compensated Surface Acoustic Wave (TC-SAW) duplexer designed for Band 8 uplink / downlink applications.

The QPQ6108 provides low insertion loss and high rejection making it an ideal choice for Small Cells. This duplexer is housed in a compact, RoHs compliant 2.00 mm x 2.50 mm x 0.87 mm surface mount package (SMP).

The QPQ6108 is part of Qorvo's extensive portfolio of RF BAW and SAW filters.



9 Pad 2.00 mm x 2.50 mm x 0.87 mm SMP

Functional Block Diagram

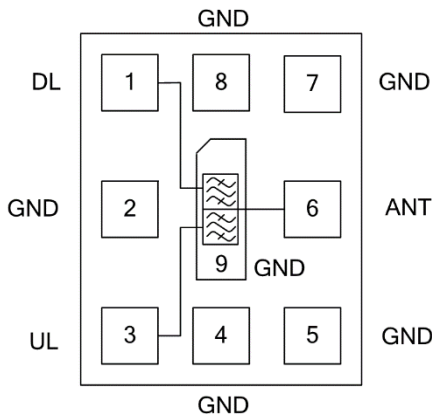

Top View

Pin Configuration

Pin No.	Label	Function
1	DL	Downlink Port
2, 4, 5, 7, 8, 9	GND	Ground Connections
3	UL	Uplink Port
6	ANT	Antenna Port for both Uplink and Downlink

Key Features

- 35 MHz Bandwidth – Band 8 Uplink & Downlink
- Temperature Compensated
- High Attenuation
- Low Loss
- No External Matching Required
- Single Input, Single Output Operation
- Small Size: 2.00 mm x 2.50 mm x 0.87 mm
- Surface Mount Package (SMP)
- RoHS Compliant, Pb-Free

Applications

- Band 8
- Base Station Infrastructure
- Small Cells
- Repeaters
- Routers
- LTE Dongles
- General Purpose Wireless

Ordering Information

Part No.	Description
QPQ6108SR	100 pieces on a 7" reel
QPQ6108TR7	2,500 pieces on a 7" reel (standard)
QPQ6108EVB	Evaluation Board

Absolute Maximum Ratings

Parameter	Rating
Storage Temperature	-40 to +125°C
Operation Temperature	-20 to +95°C
Maximum DC Voltage	5 V

Life Test

Conditions	Rating
+29 dBm DL ⁽¹⁾ , +85°C ⁽³⁾	> 293,000 hours
+23 dBm UL ⁽²⁾ , +85°C	> 293,000 hours
+29 dBm DL ⁽¹⁾ , +95°C ⁽³⁾	> 102,000 hours
+23 dBm UL ⁽²⁾ , +95°C	> 102,000 hours

Notes:

1. Power injected into Pin 1
2. CW Power injected into Pin 6
3. FD-LTE, 5MHz, 16QAM, 25 RB, PAR =8dB

Electrical Specifications ⁽⁴⁾ – Band 8 Uplink

Test conditions unless otherwise specified. Temperature Range: -20 to +95 °C

Parameter ⁽⁵⁾	Conditions	Min	Typ ⁽⁶⁾	Max	Units
Passband		880	–	915	MHz
Max Insertion Loss	880 – 915 MHz		2.9	4.0	dB
Average Insertion Loss ⁽¹⁰⁾	880 – 885 MHz		2.6	3.1	dB
	885 – 910 MHz		2.1	2.4	dB
	910 – 915 MHz		2.7	3.2	dB
Insertion Loss Variation ⁽⁷⁾	880 – 915 MHz		1.6	2.3	dB
Group Delay	880 – 915 MHz			70	ns
Group Delay Variation	880 – 915 MHz			150	ns
Input / Output Return Loss	880 – 915 MHz	9	13		dB
Attenuation ⁽⁸⁾	10 – 699 MHz	40			dB
	699 – 821 MHz	40			
	821 – 860 MHz	40			
	925 – 960 MHz	48			
	960 – 1805 MHz	35			
	1805 – 1880 MHz	40			
	1880 – 2110 MHz	40			
	2110 – 2690 MHz	40			
	2690 – 3400 MHz	25			
	3400 – 3800 MHz	20			
3800 – 5150 MHz	14				
5150 – 5850 MHz	12				
EVM ⁽¹⁰⁾	882.4 – 912.6 MHz			6.5	%
Source/Load Impedance ⁽⁹⁾	Single-ended		50		Ω

Notes:

4. All specifications are based on the Qorvo schematic for the main reference design.
5. Electrical margin has been built into the design to account for the variations due to temperature drift and manufacturing tolerances.
6. Typical values are based on average measurements of 12 devices at room temperature.
7. This is defined as the worst difference between a peak and adjacent valley within defined frequency range.
8. Relative to zero dB
9. This is the optimum impedance in order to achieve the performance shown.
10. Over any 5 MHz frequency channel bandwidth

Electrical Specifications ⁽¹⁾ – Band 8 Downlink

Test conditions unless otherwise specified. Temperature Range: -20 to +95 °C

Parameter ⁽²⁾	Conditions	Min	Typ ⁽³⁾	Max	Units
Passband		925		960	MHz
Max Insertion Loss	925 – 960 MHz		3.4	4.0	dB
Average Insertion Loss ⁽⁷⁾	925 – 930 MHz		2.5	3.0	dB
	930 – 955 MHz		2.2	3.0	dB
	955 – 960 MHz		3.0	3.5	dB
Insertion Loss Variation ⁽⁴⁾	925 – 960 MHz		1.0	2.5	dB
Group Delay	925 – 960 MHz			70	ns
Group Delay Variation	925 – 960 MHz			150	ns
Input / Output Return Loss	925 – 960 MHz	9.5	13		
Attenuation ⁽⁵⁾	10 – 699 MHz	35			dB
	699 – 832 MHz	40			
	832 – 880 MHz	45			
	880 – 912 MHz	47			
	912 – 915 MHz	45			
	980 – 1000 MHz	40			
	1000 – 1150 MHz	40			
	1150 – 1250 MHz	25			
	1250 – 1400 MHz	40			
	1400 – 1710 MHz	40			
	1710 – 1980 MHz	45			
	1980 – 2300 MHz	45			
	2300 – 2690 MHz	45			
2690 – 3400 MHz	35				
3400 – 3800 MHz	35				
3800 – 5150 MHz	20				
5150 – 5850 MHz	20				
EVM ⁽⁷⁾	927.4 – 957.6 MHz			6.5	%
2nd Harmonic Distortion(HD2)	DL Pin 24 dBm CW, ANT port HD2 in 1850 - 1920 MHz		-100		dBc
2nd Order Intermodulation Distortion (IMD2)	DL Pin 26 dBm CW @930 MHz, ANT Pin 4 dBm CW @1815 MHz, IMD2 in 885 MHz at Rx Port		-90		dBm
3rd Order Intermodulation Distortion (IMD3)	DL Two Tone Pin 24 dBm/tone, vary tone spacing to have IMD3 distortion product in UL Band		-85		dBc
5th Order Intermodulation Distortion (IMD5)	DL Two Tone Pin 24 dBm/tone, vary tone spacing to have IMD5 distortion product in UL Band		-110		dBc
Source/Load Impedance ⁽⁶⁾	Single-ended		50		Ω

Notes:

1. All specifications are based on the Qorvo schematic for the main reference design.
2. Electrical margin has been built into the design to account for the variations due to temperature drift and manufacturing tolerances.
3. Typical values are based on average measurements of 12 devices at room temperature.
4. This is defined as the worst difference between a peak and adjacent valley within defined frequency range.
5. Relative to zero dB
6. This is the optimum impedance in order to achieve the performance shown.
7. Over any 5 MHz frequency channel bandwidth

Electrical Specifications ⁽¹⁾ – Band 8 Isolation

Test conditions unless otherwise specified. Temperature Range: -20 to +95 °C

Parameter ⁽²⁾	Conditions	Min	Typ ⁽³⁾	Max	Units
Isolation	880 – 912 MHz	50			dB
	912 – 915 MHz	47			dB
	925 – 960 MHz	50			dB
Source/Load Impedance ⁽⁴⁾	Single-ended		50		Ω

Notes:

1. All specifications are based on the Qorvo schematic for the main reference design.
2. Electrical margin has been built into the design to account for the variations due to temperature drift and manufacturing tolerances.
3. Typical values are based on average measurements of 12 devices at room temperature.
4. This is the optimum impedance in order to achieve the performance shown.

QPQ6108EVB Evaluation Board

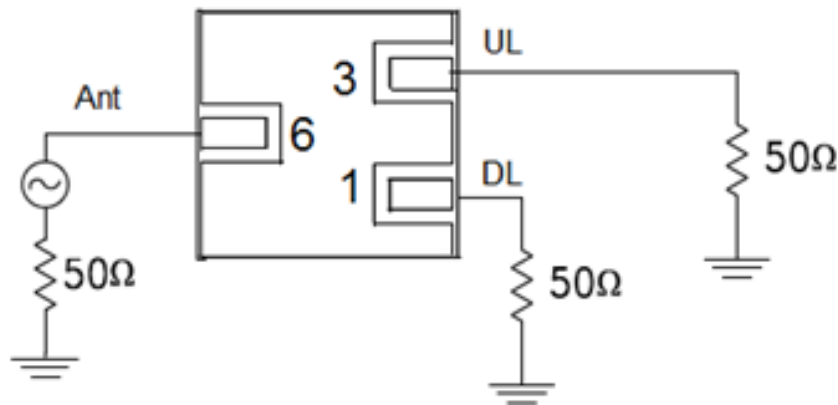

Notes:

1. Top, inner 1, inner 2 & bottom layers: 1 oz copper, Substrates 1 & 3: FR-408HR, .007" thick, Substrates 2: FR4, .027" thick, Finish plating: Nickel: 3-8 μm thick, Gold: .03-.2 μm thick, Hole plating: Copper min .0008 μm thick

Bill of Material – QPQ6108EVB

Reference Designation	Description	Manufacture	Part Number
U1	Duplexer, Band 8 TC-SAW	Qorvo	QPQ6108
P1, P2, P3	Connector, SMA RF	Radiall USA Inc.	9602-1111-018
PCB	PCB, 4-Layer FR-408HR and FR4, 0.041"	Multiple	283666

Package Dimensions

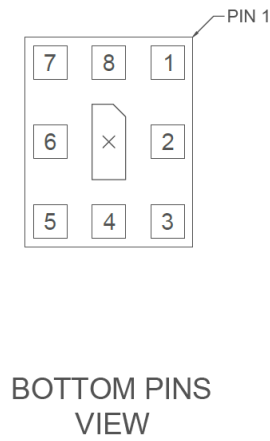
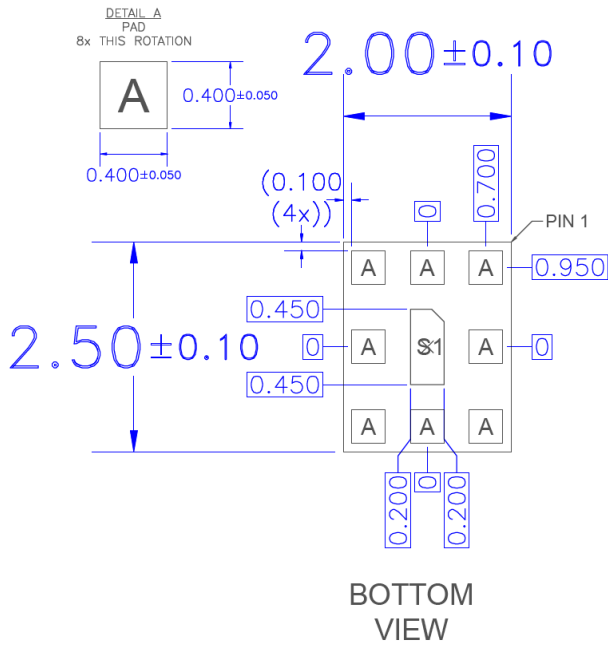
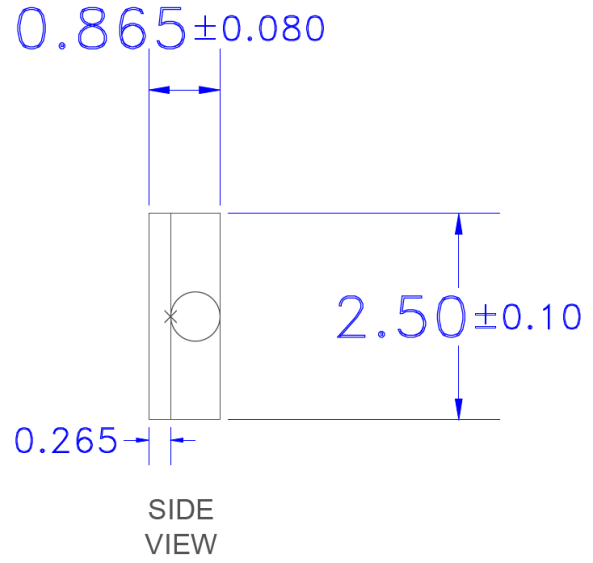
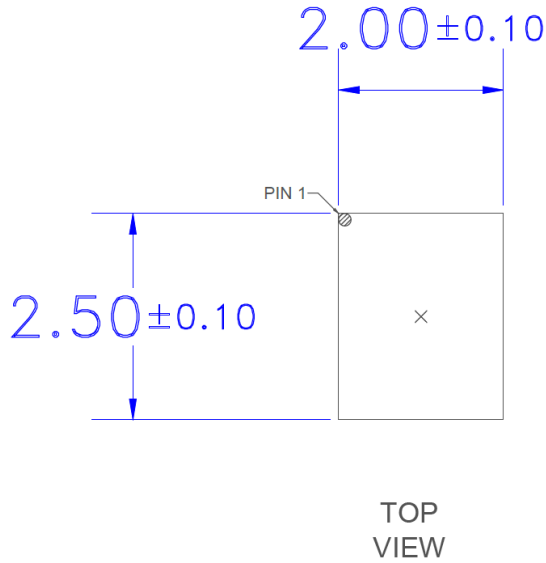

Notes:

1. All dimensions are in millimeters. Angles are in degrees.
2. Dimension and tolerance formats conform to ASME Y14.4M-1994.
3. The terminal #1 identifier and terminal numbering conform to JESD 95-1 SPP-012.

Package Marking

Package Marking

Qorvo Logo
Product Identifier: 6108
Trace Code: XXXX

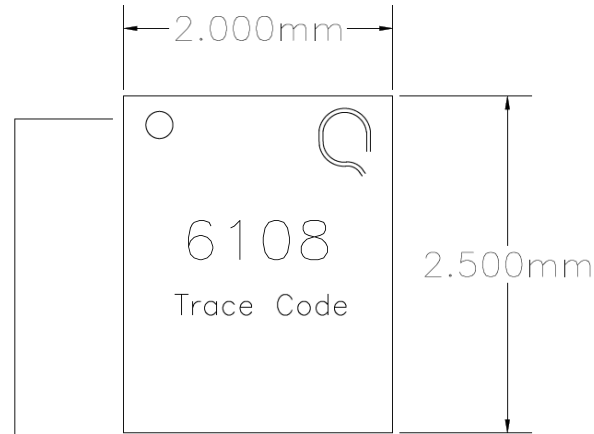

Line 1 – Pin 1 Indicator and Logo (Q5D)
Line 2 – Part Number
Line 3 – Short Trace Code (Up to 4 Characters)
Trace Code to be assigned by Sub Con

PCB Mounting Pattern

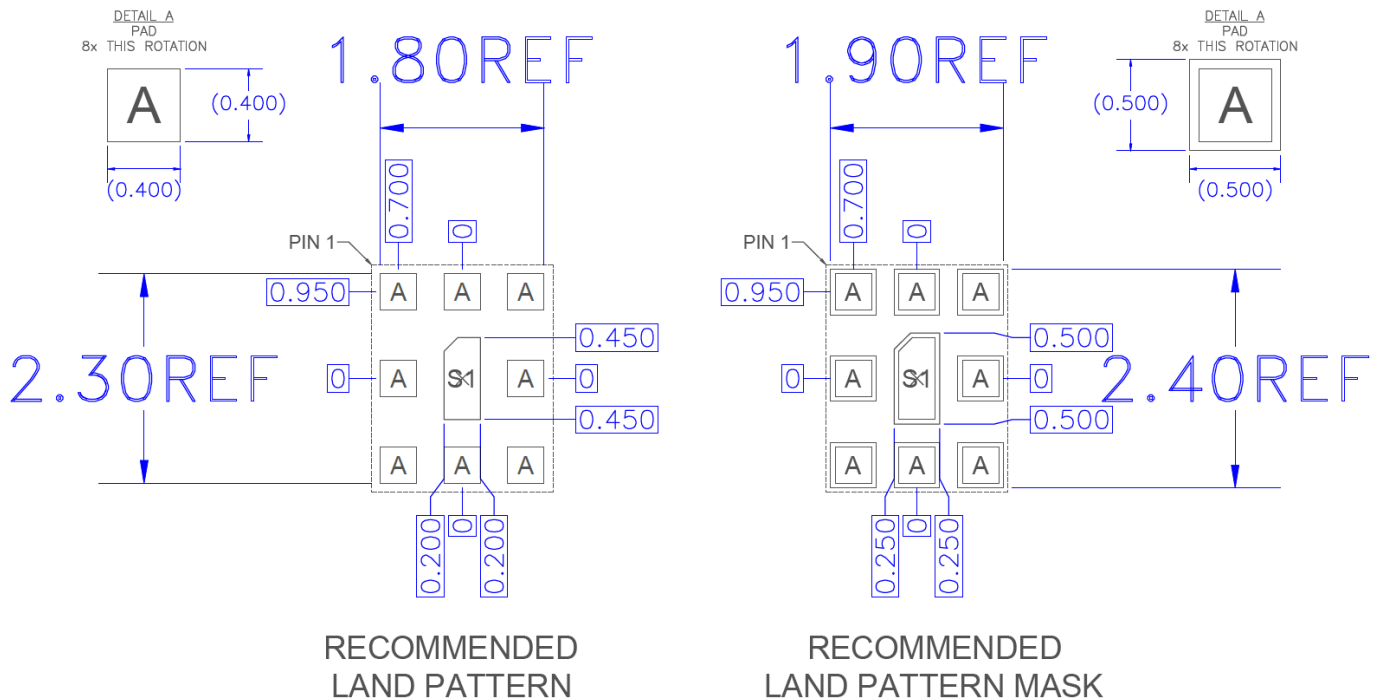

Notes:

1. All dimensions are in millimeters. Angles are in degrees.
2. This drawing specifies the mounting pattern used on the Qorvo evaluation board for this product. Some modification may be necessary to suit end user assembly materials and processes.

Tape and Reel Information – Carrier and Cover Tape Dimensions

Tape and reel specifications for this part are also available on the Qorvo website.
 Standard T/R size = 2500 pieces on a 7” reel.

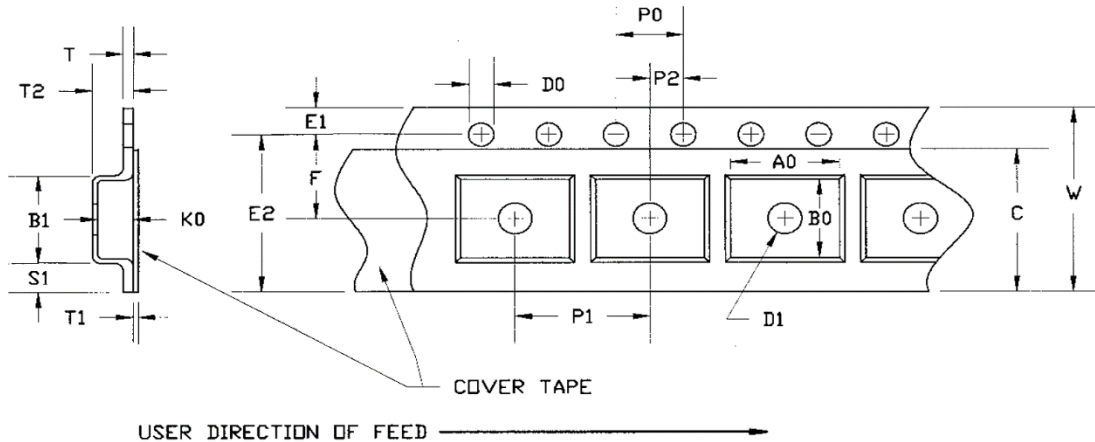

Feature	Measure	Symbol	Size (in)	Size (mm)
Cavity	Length	A0	0.092	2.34
	Width	B0	0.112	2.85
	Depth	K0	0.043	1.10
	Pitch	P1	0.157	4.00
Centerline Distance	Cavity to Perforation - Length Direction	P2	0.079	2.00
	Cavity to Perforation - Width Direction	F	0.138	3.50
Cover Tape	Width	C	0.213	5.40
Carrier Tape	Width	W	0.315	8.00

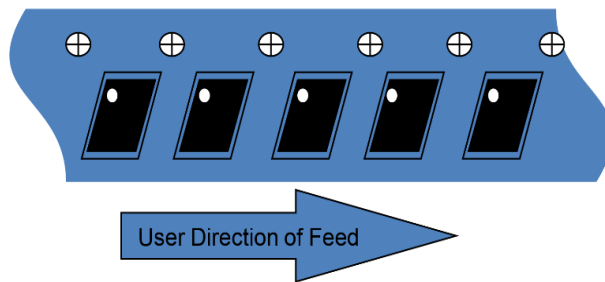

Tape and Reel Information – Reel Dimensions

Tape and reel specifications for this part are also available on the Qorvo website.
 Standard T/R size = 2,500 pieces on a 7" reel.

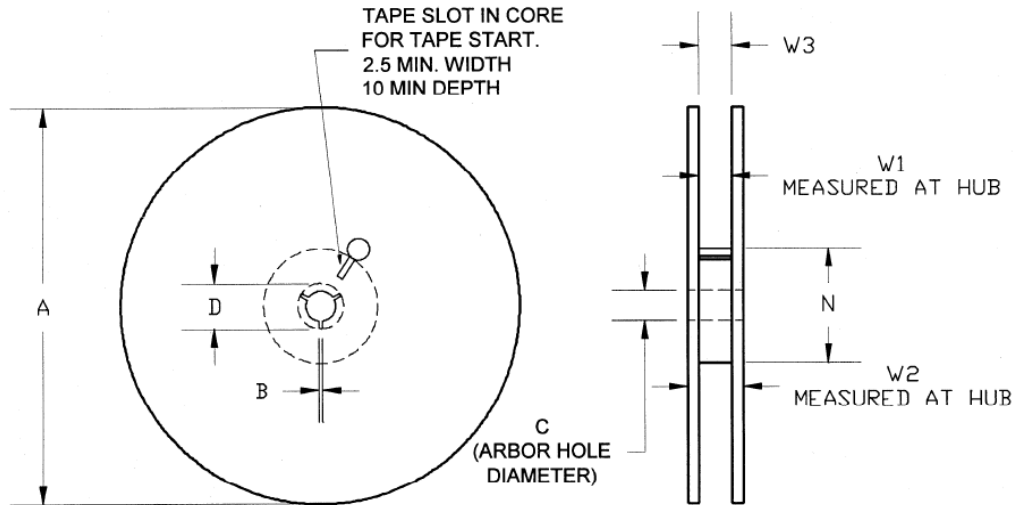

Feature	Measure	Symbol	Size (in)	Size (mm)
Flange	Diameter	A	6.969	177.0
	Thickness	W2	0.559	14.2
	Space Between Flange	W1	0.346	8.8
Hub	Outer Diameter	N	2.283	58.0
	Arbor Hole Diameter	C	0.512	13.0
	Key Slit Width	B	0.079	2.0
	Key Slit Diameter	D	0.787	20.0