

Datasheet

Midsized sensors featuring extended range and foreground suppression mode

Features



- Bipolar discrete outputs, PNP and NPN
- 128 element photo receiver for superior performance on varying colors and textures
- 400 mm sensing range in midsized QS30 housing
- Foreground suppression models for reliable detection when a fixed background is present and the object color or shape varies
- Linear multi-turn screw adjustment of cutoff distance
- Enhanced immunity to fluorescent lights
- Improved temperature compensation to minimize cutoff distance variation due to ambient temperature changes
- Powerful, highly collimated visible red sensing beam allows two sensors to be used in close proximity
- Models available with 2 m or 9 m (6.5 ft or 30 ft) cable or integral metal quick-disconnect; or 150 mm (6 in) pigtail
- Tough ABS housing is rated IEC IP67; NEMA 6
- Mounting versatility via popular 30 mm threaded barrel or side-mount



WARNING:

- **Do not use this device for personnel protection**
- Using this device for personnel protection could result in serious injury or death.
- This device does not include the self-checking redundant circuitry necessary to allow its use in personnel safety applications. A device failure or malfunction can cause either an energized (on) or de-energized (off) output condition.

Models

Models	Supply Voltage	Sensing Range	Output Type
QS30AFF400	10 to 30 V DC	Adjustable Cutoff Range: 50 to 400 mm Maximum Sensing Range: 400 mm	Bipolar (1 NPN and 1 PNP)

Standard 2 m (6.5 ft) cable models are listed.

- To order the 9 m (30 ft) cable model, add suffix **W/30** to the model number (for example, **QS30AFF400 W/30**).
- To order the 5-pin integral QD model, add suffix **Q** to the model number (for example, **QS30AFF400Q**).
- To order the 150 mm (6 in) PVC cable with a 5-pin M12 connector model, add suffix **Q5** to the model number (for example, **QS30AFF400Q5**).

Overview

Banner's WORLD-BEAM® QS30 Adjustable-Field Sensors with Foreground Suppression detect the light reflected from the background. The output changes when the light from the background is blocked.

In general, if the background is fixed and the color or shape of the objects in the foreground vary, foreground suppression mode will provide reliable detection. A foreground suppression sensor uses the background in the same way a retroreflective sensor would use a reflector. The sensor output will change whenever an object passes between itself and the background. The default mode for foreground suppression sensors is Dark Operate (DO).



Figure 1. Sensor Features



1. Green: Power Indicator LED
2. Yellow: Light Sensed Indicator LED (Flashes for Marginal Conditions)
3. Blue/Red: End-of-travel (EOT) Indicator LED
4. Cutoff Distance Adjustment Screw
5. Yellow: Output Indicator LED

Configuration Instructions

Sensor Orientation

To ensure reliable detection, orient the sensor as shown in relation to the target to be detected.

Figure 2. Optimal Orientation of Target to Sensor

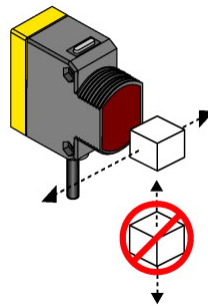

Sensor Setup - Foreground Suppression (DO mode)

1. Mount the sensor aimed at the fixed background (the distance to the background must be less than shown in [Figure 7](#) on p. 6 for your background color).
2. Turn adjustment pot **clockwise** until it clicks and EOT LED turns **on blue** (4 turns).
3. Turn the adjustment pot **counter-clockwise** until the Yellow Output LED turns **off**. This places the cutoff distance in front of the fixed background (see the figure right).
4. Place the application's darkest object into the sensor's field of view at the maximum sensor to object distance, and verify that the Yellow Output LED turns **on**. The sensor is optimized for detecting thin objects close to the fixed background and is ready for operation.
For maximum sensing reliability in applications with variations in background position or color (i.e. conveyor belts with flutter), follow these additional steps.
5. Continuing from step 4, turn adjustment pot **counter-clockwise**, counting the revolutions, until the Yellow Output LED turns **off**.
6. Turn adjustment pot **clockwise** half the number of revolutions from step 5. This will place the cutoff distance midway between the object and the background. The sensor is optimized for reliable detection in applications with thick objects and modest variation in background. The sensor is ready for operation.

Figure 3. Set cutoff distance in front of the fixed background

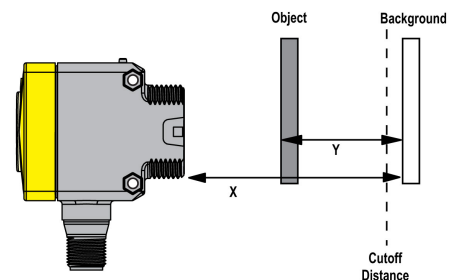

X: Distance to Background

Y: Minimum Separation Between Object and Background

Setup Example

Foreground Suppression Mode application example

Foreground Suppression Mode (also called Background Detection): The light reflected off the background is detected. The output changes when the light from the background is blocked.

In general, if the background is fixed and the color or shape of the objects in the foreground vary, foreground suppression mode will provide reliable detection. A foreground suppression sensor uses the background in the same way a retroreflective sensor would use a reflector. The sensor output will change whenever an object passes between itself and the background.

To ensure reliable foreground suppression, a minimum separation distance between the object and the background is necessary. See Figure 7 on p. 6 to determine the minimum separation distance.

Example: The sensor is positioned above a black conveyor belt at a distance of 300 mm. The objects on the conveyor are boxes of varying colors. According to Figure 7 on p. 6, the box height must be greater than 15 mm for reliable detection against a black background. In this application, reliable detection will be achieved when set up according to the procedure outlined in Sensor Setup - Foreground Suppression.

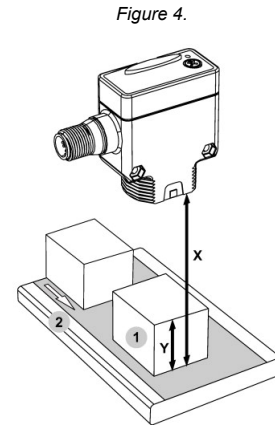

1. Object
2. Background (Conveyor)

X: Distance to Background = 300 mm

Y: Minimum Separation Between Object and Background > 15 mm

Remote Configuration

The Remote Configuration function may be used to SET the sensor's cutoff distance remotely or to disable the cutoff distance adjustment screw for security. Connect the gray/Input wire of the sensor to ground (0V dc), with a remote switch connected between them. Pulse the gray/Input wire according to the diagrams in the configuration procedures. The length of the individual pulses is equal to the value T where $0.04 \text{ s} \leq T \leq 0.8 \text{ s}$.

Figure 5. Connecting the gray/Input wire

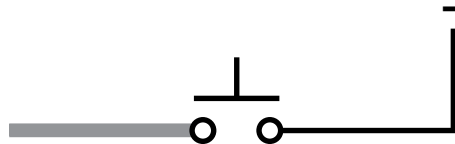

Background SET:

The distance to the fixed background is sampled; the sensor optimizes the cutoff distance in front of the distance to the fixed background. In RUN mode, objects located between the sensor face and the cutoff distance are sensed; anything beyond the cutoff distance (e.g., fixed background) is ignored.

Step	Procedure	Result
Set Fixed Background	Present fixed background Single-pulse the gray/Input wire 	Green Power and Yellow Light Sensed LEDs flash alternately 3 times (EOT LED alternately flashes Red/Blue 3 times at the same time)
Return to Run Mode	Sensor returns automatically to RUN mode	SET accepted: Sensor returns directly to RUN mode SET failed: Feedback is displayed for 2 seconds (Yellow Light Sensed LED OFF, Green Power LED flashes 4 times)

Cutoff Distance Adjustment Screw Disable/Enable:

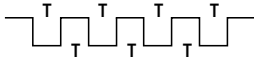
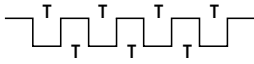
Step	Procedure	Result
Disable	Quad-pulse the gray/Input wire 	EOT LED flashes Red 4 times Cutoff point adjustment screw disabled
Enable	Quad-pulse the gray/Input wire 	EOT LED flashes Blue 4 times Cutoff point adjustment screw enabled

End-of-Travel (EOT) Indicator LED

Cutoff Distance Adjustment Screw Status	Result
Cutoff distance adjustment screw in between max. and min. end-of-travel limits	EOT LED OFF
Cutoff distance adjustment screw turned clockwise to max. end-of-travel limit	EOT LED ON Blue
Cutoff distance adjustment screw turned counter-clockwise to min. end-of-travel limit	EOT LED ON Red
Cutoff distance adjustment screw turned while disabled	EOT LED alternately flashes Red/Blue 4 times

Output States

Foreground Suppression Mode				
Output	Object Between Sensor Face and Cutoff Distance		No Object Between Sensor Face and Fixed Background	
	LO	DO	LO	DO
Yellow Output LED	OFF	ON	ON	OFF
Black Wire (Pin 4)	OFF	ON	ON	OFF
White Wire (Pin 2)	OFF	ON	ON	OFF
Yellow Light Sensed LED	OFF		ON or Flashing (if < 1.5x excess gain)	

Wiring Diagrams

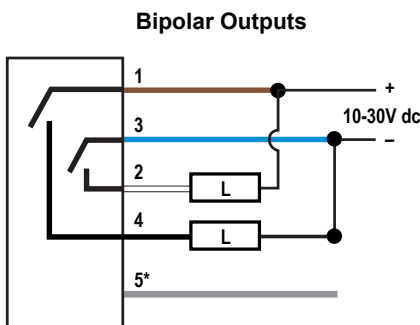

- Key:**
 1 = Brown
 2 = White
 3 = Blue
 4 = Black
 5 = Gray (Input*)
 L = Load

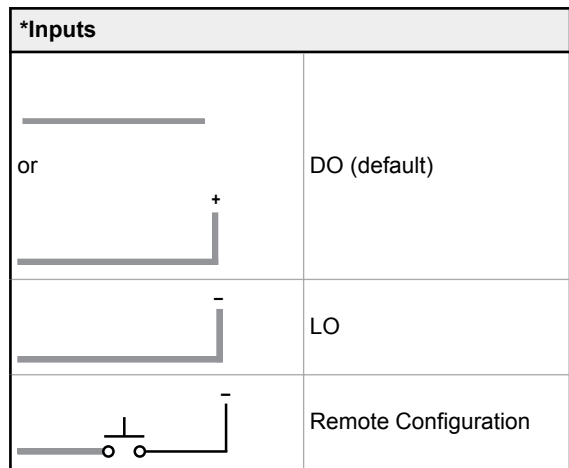

Specifications

Sensing Range

Adjustable Cutoff Range: 50 to 400 mm
Maximum Sensing Range: 400 mm

Supply Voltage and Current

10 to 30 V dc (10% maximum ripple within specified limits); Current consumption: < 80 mA at 10 V dc; < 40 mA at 30 V dc

Supply Protection

Protected against reverse polarity and transient voltages

Sensing Beam

Visible red LED, 660 nm

Output Configuration

Bi-polar Models: Solid-state bipolar (SPDT): both sinking and sourcing
Off-state leakage current: < 5 µA at 30 V dc

ON-state saturation voltage:

- **NPN:** less than 1.5 V at 100 mA
- **PNP:** less than 2.0 V at 100 mA

Output Protection Circuitry

Protected against false pulse on power-up and continuous overload or short circuit of outputs.

Output Response

5 millisecond ON/OFF;
200 ms delay on power-up; outputs do not conduct during this time

Repeatability

750 µs

Adjustments

Four-turn adjustment screw sets cutoff distance between min. and max. positions, clutched at both ends of travel

Indicators

2 Indicator LEDs on sensor top:

- **Green solid:** Power ON
- **Amber solid:** Light sensed (excess gain > 1.5x)
- **Amber flashing:** Marginal sensing condition (excess gain < 1.5x)

2 Indicator LEDs on sensor back:

- Small Blue/Red End-of-travel (EOT) LED
- Large Amber Output LED

Construction

ABS housing

QD models: nickel-plated brass

Environmental Rating

IEC IP67; NEMA 6

Connections

2 m (6.5 ft) 5-wire PVC cable, 9 m (30 ft) PVC cable, or 5-pin Integral QD or Euro-style 150 mm (6 in) pigtail QD, depending on model

Operating Conditions

Temperature: -20 °C to +60 °C (-4 °F to +140 °F)

Humidity: 95% at +50 °C maximum relative humidity (non-condensing)

Certifications



Performance Curves

Figure 6. Typical emitter spot diameter vs. distance

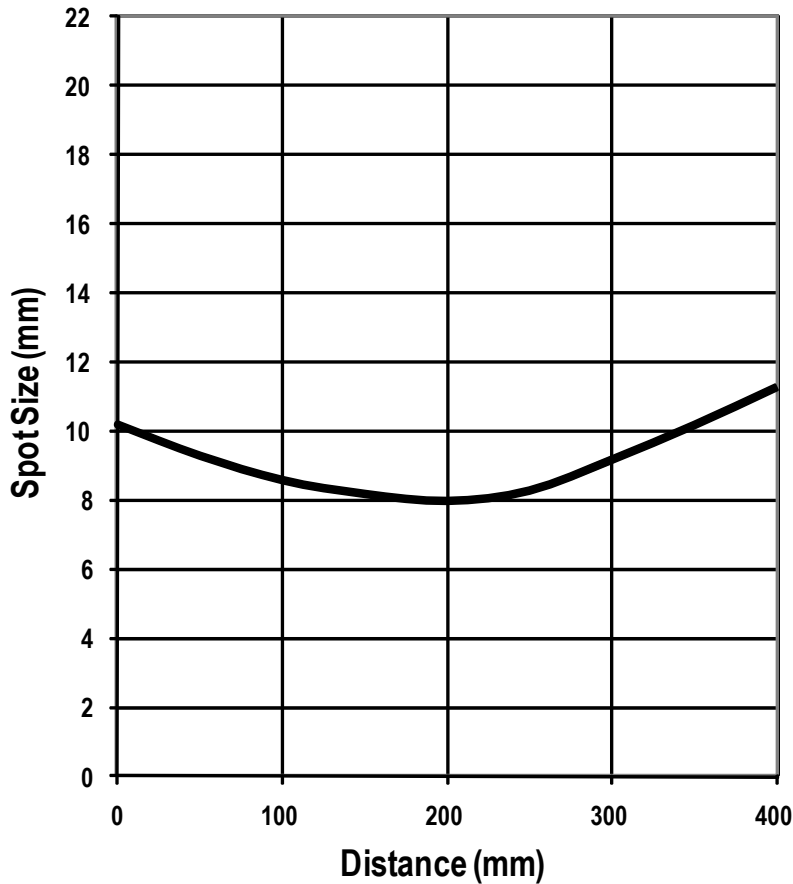
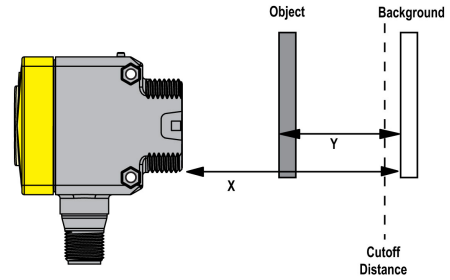
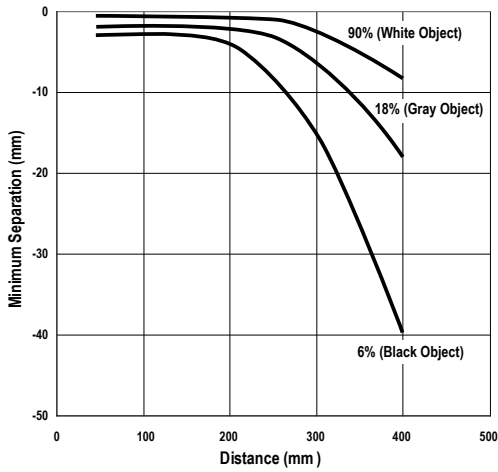

Figure 7. Minimum separation distance* between object and background: foreground suppression mode



* Targets with severe color contrasts can increase the Minimum Separation Distance

Excess Gain Curves

Figure 8. QS30AFF400 Excess Gain Curve (based on 90% White Card)

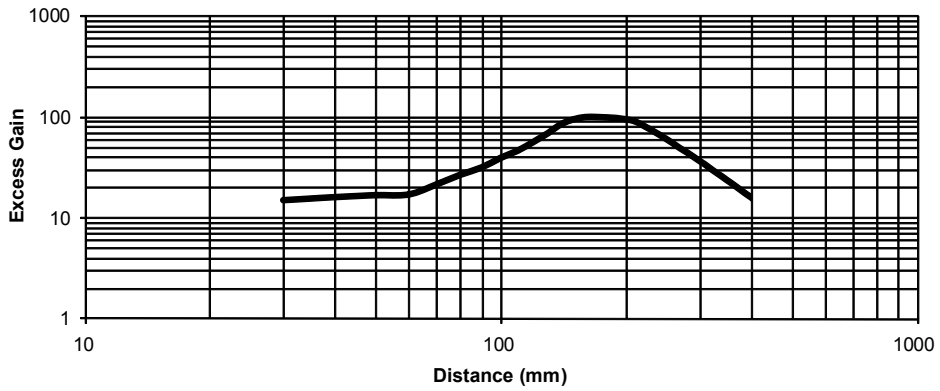

Dimensions (QD Models)

