

Datasheet

High-Power Opposed-Mode Sensors

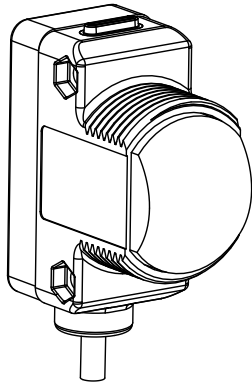

- Infrared beam with high excess gain — range of over 213 m (700 ft)
- Excellent noise immunity
- Excellent for applications where high sensing power is required due to long sensing range or contamination on lenses
- Excellent optical performance throughout the sensing range
- Easy two frequency selection to help prevent crosstalk, see Application Note (See [Specifications](#) on p. 3)
- Easy-to-read operating status indicators with bargraph display
- Bipolar discrete outputs, PNP and NPN
- Light Operate and Dark Operate models available
- Models available with 2 m or 9 m (6.5 ft or 30 ft) cable or quick-disconnect fitting
- Tough ABS housing is rated IEC IP67; NEMA 6P; QD models are washdown tested to DIN 40050-9 (IEC IP69K)
- Unique water/debris-shedding lens design reduces lens contamination; lens material survives impact, washdown and cleaning chemicals
- Encapsulated electronics
- Compact housing — mounting versatility via popular 30 mm threaded barrel or side-mount



WARNING:

- **Do not use this device for personnel protection**
- Using this device for personnel protection could result in serious injury or death.
- This device does not include the self-checking redundant circuitry necessary to allow its use in personnel safety applications. A device failure or malfunction can cause either an energized (on) or de-energized (off) output condition.

Models

Model ¹	Cable	Supply Voltage	Output Type
<i>Emitters</i>			
QS30EX	2 m (6.5 ft) 5-wire cable	10 V DC to 30 V DC	—
QS30EXQ	5-pin Euro-style QD		
<i>Receivers</i>			
QS30ARX	2 m (6.5 ft) 5-wire cable	10 V DC to 30 V DC	Bipolar NPN/PNP Light Operate
QS30ARXQ	5-pin Euro-style QD		
QS30RRX	2 m (6.5 ft) 5-wire cable		Bipolar NPN/PNP Dark Operate
QS30RRXQ	5-pin Euro-style QD		

Overview

Banner QS30 Series high-power opposed-mode sensors are extremely rugged, powerful, and leakproof. They are designed to withstand the most demanding industrial applications, including high-pressure washdown areas. They are powerful enough to burn through heavy fog, dust, and most types of industrial and process contamination.

The sensor's electronics are epoxy-encapsulated for maximum resistance to mechanical shock and vibration. The popular WORLD-BEAM-style housing provides multiple mounting configurations in a minimum of space.

¹ Standard 2 m (6.5 ft) cable models are listed.

- 9 m (30 ft) cables are available by adding suffix W/30 to the model number of any cabled sensor (for example, QS30EX W/30). A model with a QD connector requires a mating cable (see [Cordsets](#) on p. 4).



The innovative circuitry used in these sensors provides the best EMI/RFI noise immunity of any non-synchronized emitter/receiver pair. For applications where optical crosstalk between multiple sensor pairs may be a problem, the sensors provide a choice between two frequencies (A and B). (Each emitter must be set to the same frequency as its receiver, see [Sensor Alignment](#) on p. 3.)

Light Operate and Dark Operate outputs are available, depending on the model. Each model has two outputs that switch simultaneously: one each NPN (sinking) and PNP (sourcing).

Additional configuration options are available; contact Banner Engineering for information about the following options:

- Additional modulation frequency choices (up to four)
- Modified sensor gain
- ON-delay or OFF-delay settings
- Fixed modulation frequency models

Each sensor has a green Power ON/OFF indicator and amber indicators for the selected modulation frequency. In addition, receivers have an amber LED that lights when the outputs are conducting, plus a 4-element light bar that indicates signal strength, relative to the switch point (the higher the number lit, the more light is received).

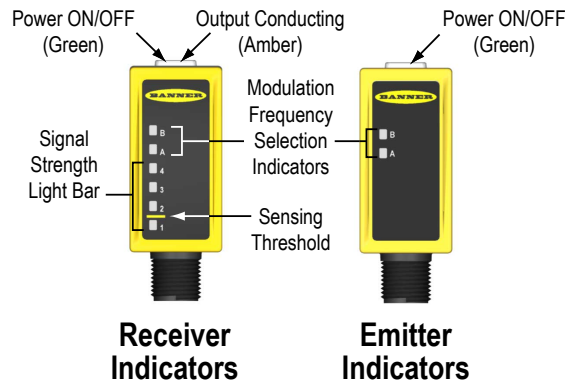
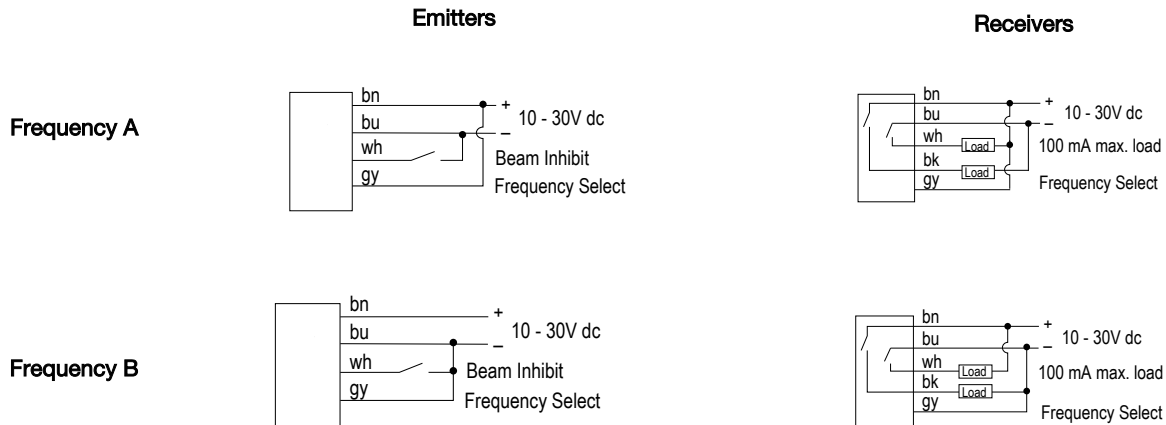

Figure 1. Receiver and Emitter Indicators

Wiring Diagrams



Sensor Configuration

The modulation frequency (A or B) is selected by the state of the gray wire (on cabled models; pin 5 on QD models – see [Wiring Diagrams](#) on p. 2). A “+” voltage or no connection selects frequency A; connecting it to “-” selects frequency B.

To disable (or inhibit) the emitter LED for testing the receiver, attach the white wire to “-” voltage.

Sensor Alignment

Adjust the emitter first, then the receiver.

1. Verify that both sensors are wired for the same modulation frequency, then adjust the emitter's position until the receiver signal strength light bar indicates its highest amount of signal received (the highest number lit).
2. Tighten the emitter mounting hardware, then repeat the process for the receiver.
3. To achieve the best crosstalk immunity, position a single matched emitter within the receiver's field of view (15 degrees).
4. When it is necessary to position an alternate emitter in the receiver's field of view, sensor alignment is required to ensure the matched frequency emitter provides the stronger signal to its receiver, and the alternate frequency emitter does not reduce the signal strength of the receiver (as indicated by the 4-element signal strength light).

Specifications

Supply Voltage and Current

Emitter: 10 V DC to 30 V DC (10% maximum ripple within specified limits); supply current (exclusive of load current): at less than 70 mA
Receiver: 10 V DC to 30 V DC (10% maximum ripple within specified limits); supply current (exclusive of load current): at less than 22 mA (exclusive of load)

Beam

Infrared, 875 nm

Sensing Range

Excess gain of 2 at 213 m (700 ft)

Output Configuration

Bipolar current sinking (NPN) white wire; current sourcing (PNP) black wire

Output Rating

100 mA max

OFF-state leakage current: less than 1 microamp @ 30 V DC
ON-state saturation voltage: less than 1 V @ 10 mA DC; less than 1.5 V @ 150 mA DC
 Protected against false power-up and continuous overload or short circuit of outputs

Required Overcurrent Protection



WARNING: Electrical connections must be made by qualified personnel in accordance with local and national electrical codes and regulations.

Overcurrent protection is required to be provided by end product application per the supplied table.
 Overcurrent protection may be provided with external fusing or via Current Limiting, Class 2 Power Supply.
 Supply wiring leads < 24 AWG shall not be spliced.
 For additional product support, go to www.bannerengineering.com.

Supply Wiring (AWG)	Required Overcurrent Protection (Amps)
20	5.0
22	3.0
24	2.0
26	1.0
28	0.8
30	0.5

Output Response Time

30 milliseconds ON and 30 milliseconds OFF; 5 ms repeatability

Adjustments

Light Operate/Dark Operate — dependent on model selected
Frequency via gray wire

A: Gray (+)

B: Gray (-)

Emitter only: LED inhibit via white wire White (-) turns emitter LED OFF (to allow verification of sensor operation)

Indicators

Green LED: Power ON
 Frequency indicator (A or B)

Receiver only:

Two LEDs (Green and Amber) Output conducting
 4-LED Signal Strength light bar

Environmental Rating

Cabled models: IEC IP67, NEMA 6P
QD models: IP69K per DIN 40050-9 per DIN 40050-9

Construction

ABS plastic housing; COP plastic lens

Connection

5-wire cable (2 m or 9 m) or 5-pin integral Euro-style quick-disconnect fitting

Operating Conditions

-20 °C to +60 °C (-4 °F to +140 °F)
 95% maximum relative humidity (non-condensing)

Mounting Torque

Maximum 4.5 N·m (40 lbf·in) with included 30 mm mounting nut

Application Notes

1. When multiple sensors are used in close proximity (see Figure 2, Beam Width for guidance on separation distance), position sensors such that the alternate frequency emitter is not within the receiver's field of view. Contact the Banner Application team for additional information
2. Prolonged outdoor use in direct sunlight may cloud the lens. Contact Banner for other outdoor solutions
3. Conditions in outdoor environments such as rain or fog can cause optical short circuits resulting in a larger effective beam size

Certifications



Performance Curves

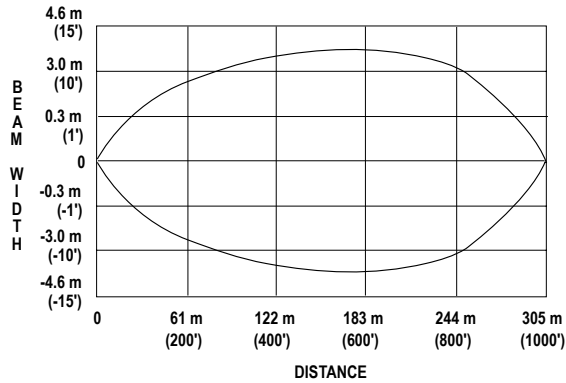

Figure 2. Beam Pattern

Effective Beam: 33 mm

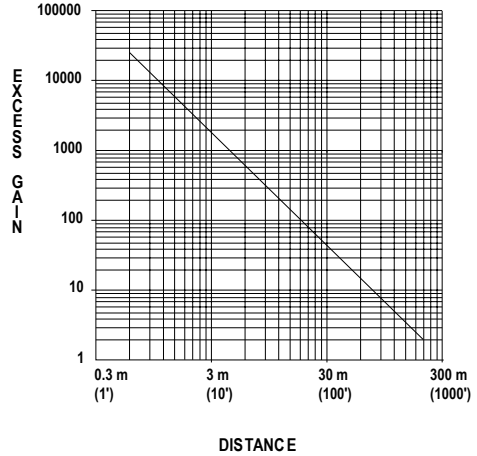
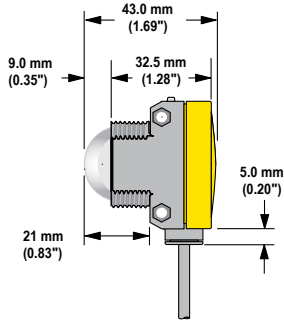

Figure 3. Excess Gain

Dimensions

Cabled Models



QD Models

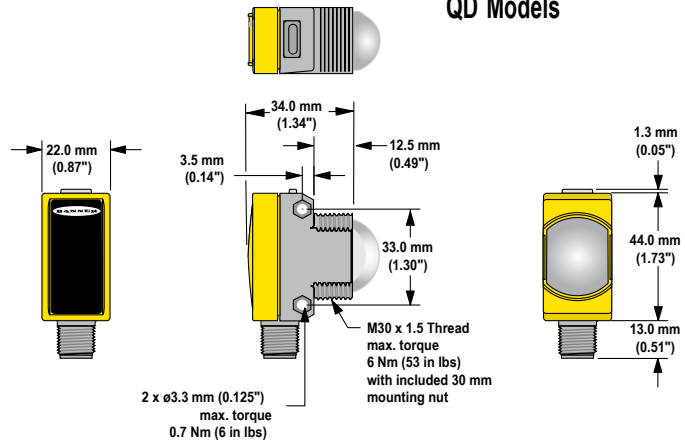

Accessories

Cordsets

5-Pin Threaded M12/Euro-Style Cordsets—Single Ended				
Model	Length	Style	Dimensions	Pinout (Female)
MQDC1-501.5	0.50 m (1.5 ft)	Straight		<p>1 = Brown 2 = White 3 = Blue 4 = Black 5 = Gray</p>
MQDC1-506	1.83 m (6 ft)			
MQDC1-515	4.57 m (15 ft)			
MQDC1-530	9.14 m (30 ft)			