

QS8004xHx

4A Over Voltage Self-protection TRIACS

RoHS

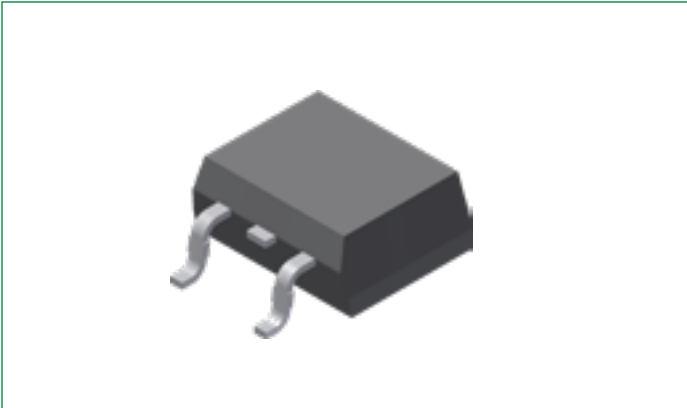

Description

This 4 Amp Over-voltage switch integrates a TRIAC structure with high voltage clamping function to ensure capability of withstand high over-voltage events, such as line transients described in the IEC 61000-4-5 standards.

This bidirectional solid-state switch series is designed for AC switching and phase control applications such as motor speed and temperature modulation controls, lighting controls, and static switching relays.

Sensitive gate Triacs can be directly driven by microprocessor or popular opto-couplers/isolators.

Schematic Symbol

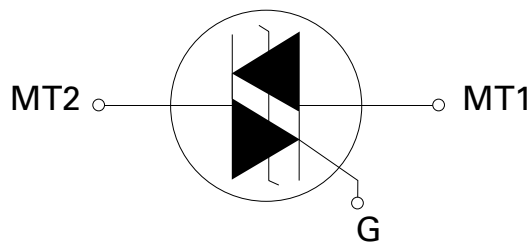

Features

- Glass-passivated junctions
- Voltage capability up to 800 V
- Surge capability up to 55 A
- Solid-state switching eliminates arcing or contact bounce that creates voltage transients
- No contacts to wear out from reaction of switching events
- Restricted (or limited) RFI generation, depending on activation point of sine wave
- Requires only a short gate activation pulse in each half-cycle

Applications

- Fridge or Air conditioner compressor control
- Industrial AC switching control
- Motor control
- White goods and household appliances

Maximum Ratings

Symbol	Characteristics	Conditions	Value	Unit
$I_{T(RMS)}$	RMS On-state Current (Full Sine Wave)	$T_C = 118\text{ }^\circ\text{C}$	4	A
I_{TSM}	Non-repetitive Surge Peak On-state Current (Full Cycle, T_J Initial = $25\text{ }^\circ\text{C}$)	$f = 50\text{ Hz}$, $t = 20\text{ ms}$	46	A
		$f = 60\text{ Hz}$, $t = 16.7\text{ ms}$	55	
I^2t	I^2t Value for Fusing	$t_p = 8.3\text{ ms}$	12.5	A^2s
di/dt	Critical Rate of Rise of On-state Current	$I_G = 50\text{ mA}$ with $\leq 0.1\text{ }\mu\text{s}$ rise time, $f = 60\text{ Hz}$, $T_J = 125\text{ }^\circ\text{C}$	100	$\text{A}/\mu\text{s}$
I_{GTM}	Peak Gate Trigger Current	$t_p = 20\text{ }\mu\text{s}$, $T_J = 125\text{ }^\circ\text{C}$	4	A
$P_{G(AV)}$	Average Gate Power Dissipation	$T_J = 125\text{ }^\circ\text{C}$	0.3	W
T_{STG}	Storage Temperature	–	-40 to 150	$^\circ\text{C}$
T_J	Operating Junction Temperature	–	-40 to 125	$^\circ\text{C}$
V_{PP}^1	Non-repetitive Line Peak Mains Voltage	$T_J = 25\text{ }^\circ\text{C}$	2	kV

Note 1: According to the test described in IEC 61000-4-5 standard and Figure 12

Electrical Characteristics ($T_J = 25\text{ }^\circ\text{C}$ unless otherwise specified)

Symbol	Conditions	Quadrant		QS8004DH2	QS8004DH4	Unit
I_{GT}	$V_D = 12\text{ V}$, $R_L = 60\text{ }\Omega$	I – II – III	Max.	10	35	mA
V_{GT}	$V_D = 12\text{ V}$, $R_L = 60\text{ }\Omega$	I – II – III	Max.	1.3	1.3	V
V_{GD}	$V_D = V_{DRM}$, $R_L = 3.3\text{ k}\Omega$, $T_J = 125\text{ }^\circ\text{C}$	All	Min.	0.2	0.2	V
I_H	$I_T = 200\text{ mA}$	–	Max.	20	30	mA
$(dv/dt)_C$	$(di/dt)_C = 2.16\text{ A/ms}$, $T_J = 125\text{ }^\circ\text{C}$	–	Min.	2	2	$\text{V}/\mu\text{s}$
t_{gt}	$I_G = 2 \times I_{GT}$, $P_W = 15\text{ }\mu\text{s}$, $I_T = 5.6\text{ A}_{PK}$	–	Typ.	2.5	3.0	μs
dv/dt	$V_D = 2/3 V_{DRM}$, Gate Open, $T_J = 125\text{ }^\circ\text{C}$	All	–	200	400	$\text{V}/\mu\text{s}$
V_{CL}	$I_{CL} = 0.1\text{ mA}$, $T_P = 1\text{ ms}$	All	Min.	850	850	V

Thermal Characteristics

Symbol	Characteristics	Value	Unit
$R_{\theta(JC)}$	Thermal Resistance, junction-to-case (AC)	1.5	$^\circ\text{C}/\text{W}$
$R_{\theta(JA)}$	Thermal Resistance, junction-to-ambient	70	$^\circ\text{C}/\text{W}$

Static Characteristics

Symbol	Conditions	Value			Unit
		Min.	Typ.	Max.	
V_{TM}	$I_{TM} = 5.6\text{ A}$, $t_p = 380\text{ }\mu\text{s}$	–	–	1.4	V
I_{DRM} / I_{RRM}	$V_{DRM} = V_{RRM}$, $T_J = 25\text{ }^\circ\text{C}$	–	–	5	μA
I_{DRM} / I_{RRM}	$V_{DRM} = V_{RRM}$, $T_J = 125\text{ }^\circ\text{C}$	–	–	2	mA

Characteristic Curves

Figure 1: Definition of Quadrants

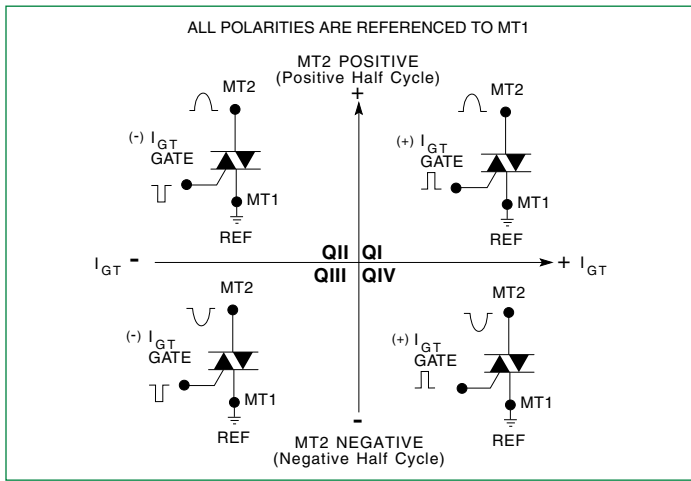

Figure 2: Normalized DC Gate Trigger Current for all Quadrants vs. Junction Temperature

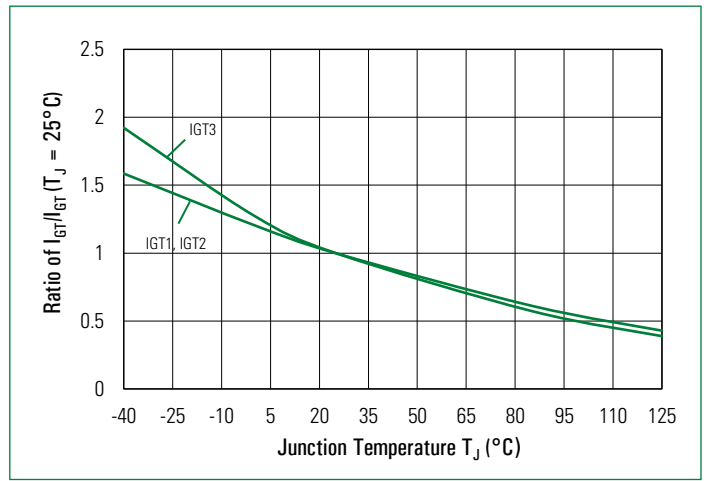

Figure 3: Normalized DC Holding Current vs. Junction Temperature

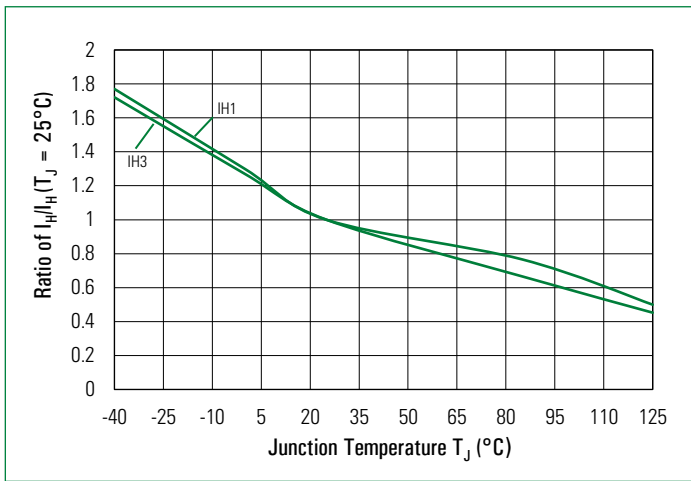

Figure 4: Normalized DC Gate Trigger Voltage for all Quadrants vs. Junction Temperature

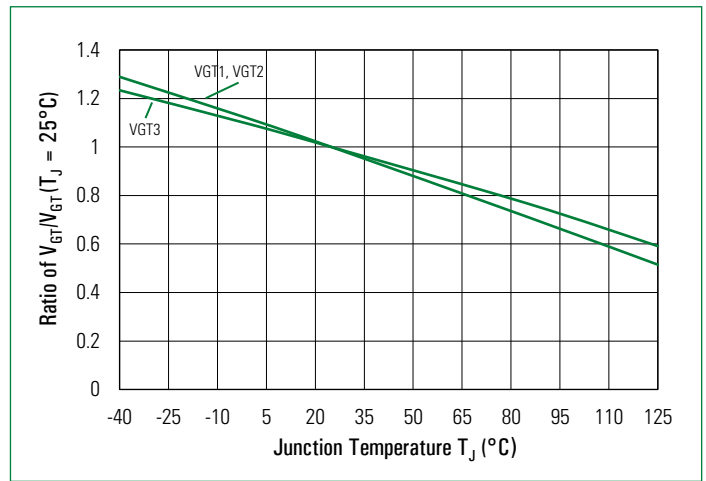

Figure 5: Typical Power Dissipation vs. RMS On-State Current

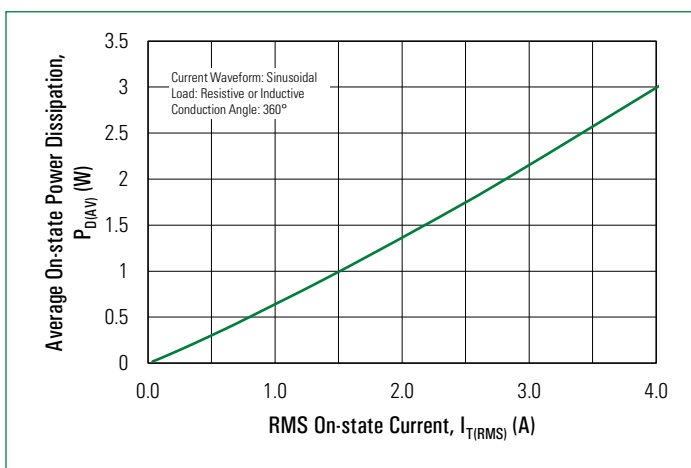

Figure 6: Maximum Allowable Case Temperature vs. On-State Current

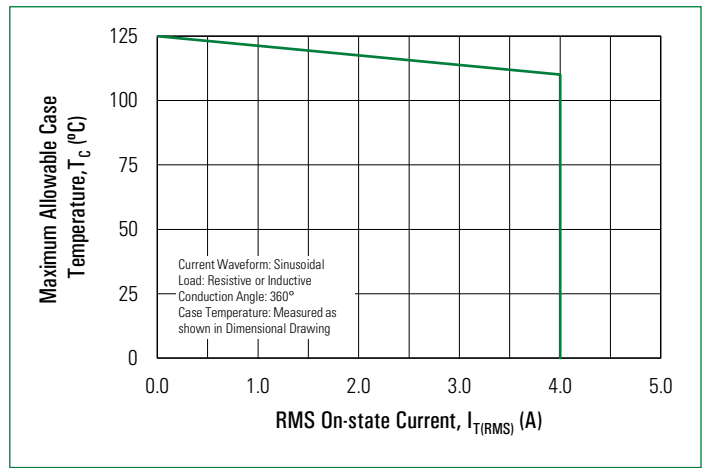

Figure 7: Maximum Allowable Ambient Temperature vs. On-State Current

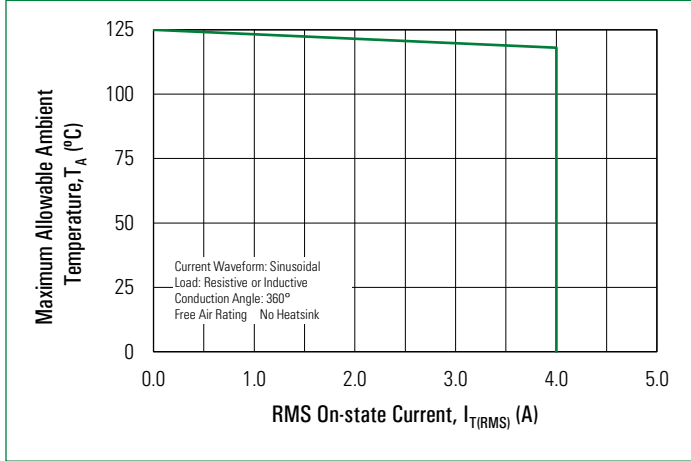

Figure 8: Typical On-State Current vs. On-State Voltage

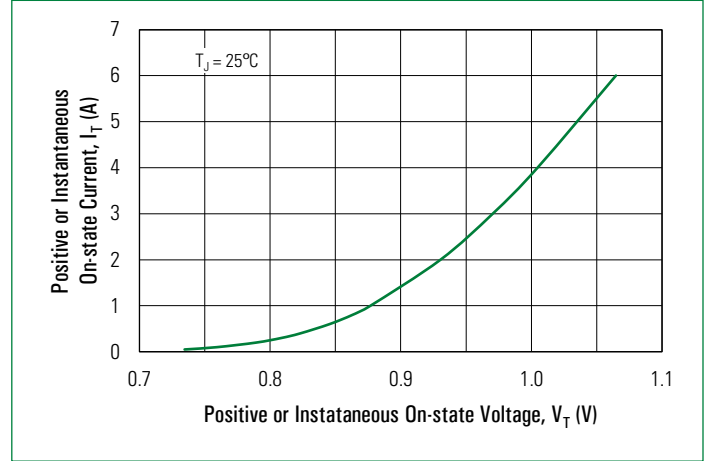

Figure 9: Normalized Clamping Voltage vs. Junction Temperature

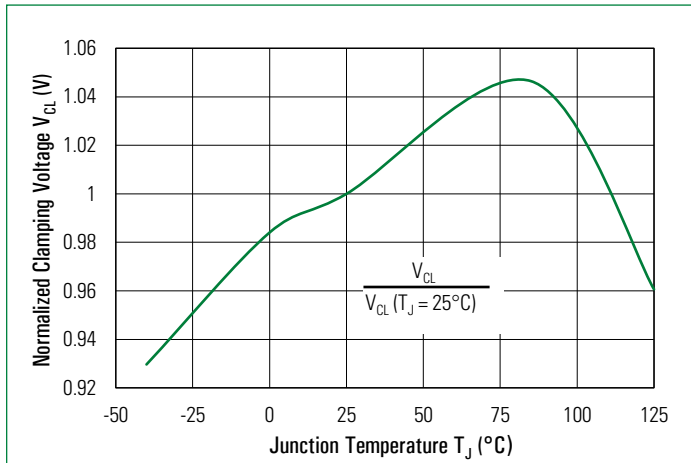
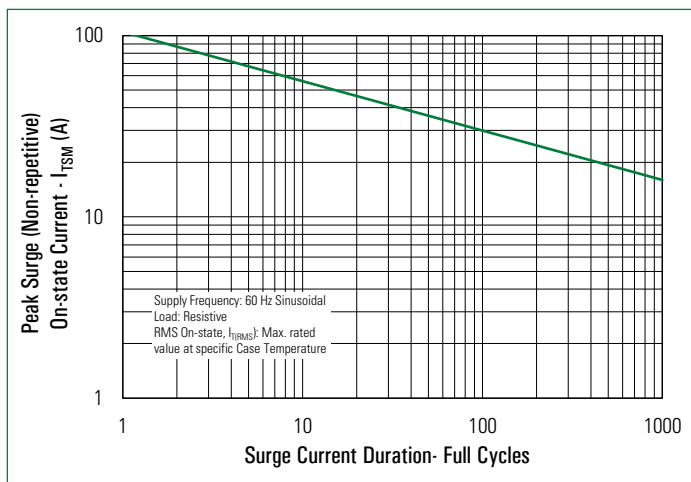

Figure 10: Surge Peak On-State Current vs. Number of Cycles



Notes:

1. Gate control may be lost during and immediately following surge current interval.
2. Overload may not be repeated until junction temperature has returned to steady-state rated value.

Fig. 11. Test Circuit for Inductive and Resistive Loads with Conditions Equivalent to IEC 61000-4-5

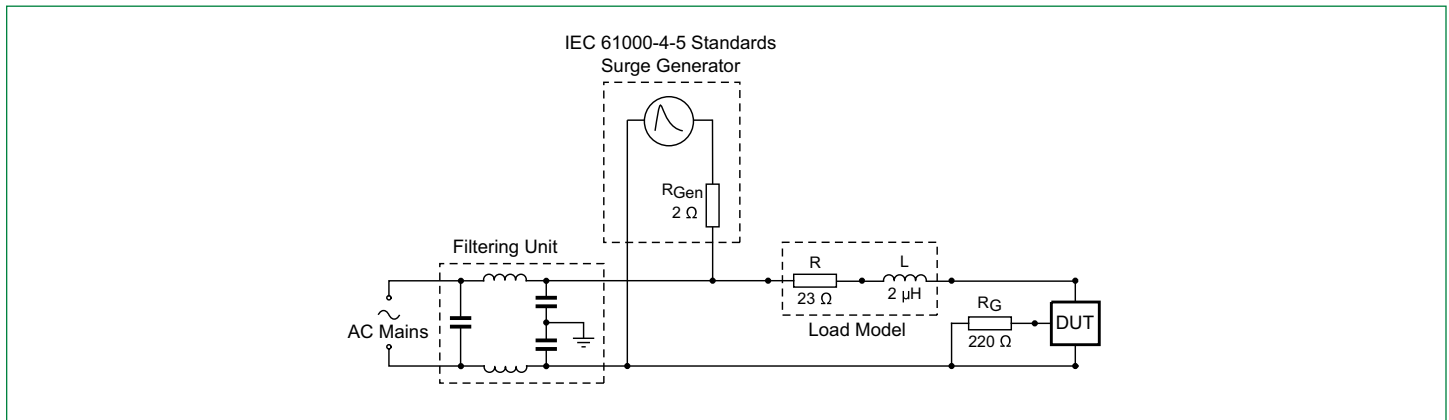

Soldering Parameters

Reflow Condition	Pb – Free assembly	
Pre Heat	- Temperature Min ($T_{s(min)}$)	150°C
	- Temperature Max ($T_{s(max)}$)	200°C
	- Time (min to max) (t_s)	60 – 120 seconds
Average ramp up rate (Liquidus Temp) (T_L) to peak	3°C/second max.	
$T_{s(max)}$ to T_L - Ramp-up Rate	3°C/second max.	
Reflow	- Temperature (T_L) (Liquidus)	217°C
	- Time (t_L)	60 – 150 seconds
Peak Temperature (T_p)	260 ^{+0/-5} °C	
Time within 5°C of actual peak Temperature (t_p)	30 seconds max.	
Ramp-down Rate	6°C/second max.	
Time 25°C to peak Temperature (T_p)	8 minutes max.	
Do not exceed	260°C	

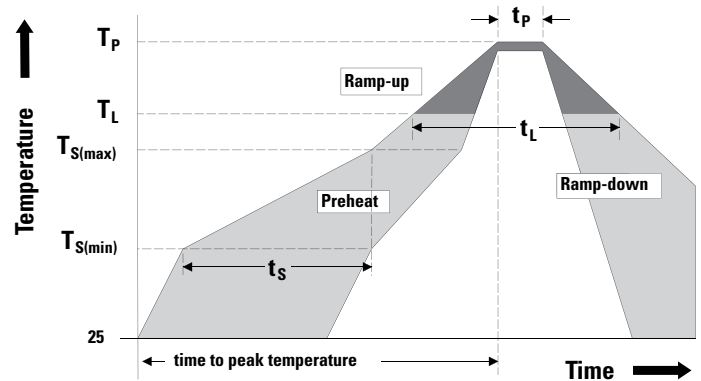

Physical Specifications

Terminal Finish	100% Matte Tin-plated
Body Material	UL recognized compound meeting flammability rating 94 V-0
Terminal Material	Copper Alloy

Design Considerations

Careful selection of the correct component for the application’s operating parameters and environment will go a long way toward extending the operating life of the Thyristor. Good design practice should limit the maximum continuous current through the main terminals to 75% of the component rating. Other ways to ensure long life for a power discrete semiconductor are proper heat sinking and selection of voltage ratings for worst case conditions. Overheating, overvoltage (including dv/dt), and surge currents are the main killers of semiconductors. Correct mounting, soldering, and forming of the leads also help protect against component damage.

Environmental Specifications

Test	Specifications and Conditions
AC Blocking	MIL-STD-750, M-1040, Cond A Applied Peak AC voltage @ 125°C for 1008 hours
Temperature Cycling	MIL-STD-750, M-1051, 1000 cycles; -55°C to +150°C; 15-min dwell-time
Temperature/Humidity	EIA / JEDEC, JESD22-A101; 1008 hours; 320V - DC: 85°C; 85% rel humidity
High-temp Storage	MIL-STD-750, M-1031, 1008 hours; 150°C
Low-temp Storage	1008 hours; -40°C
Resistance to Solder Heat	MIL-STD-750 Method 2031
Solderability	ANSI/J-STD-002, category 3, Test A
Moisture Sensitivity Level	MSL Level 1

Package Dimensions TO - 252AA (D-package)

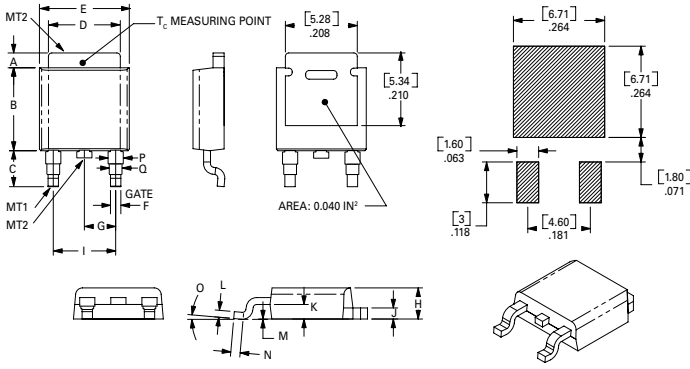

Dimension	Inches			Millimeters		
	Min	Typ	Max	Min	Typ	Max
A	0.040	0.043	0.050	1.02	1.09	1.27
B	0.235	0.243	0.245	5.97	6.16	6.22
C	0.106	0.108	0.113	2.69	2.74	2.87
D	0.205	0.208	0.213	5.21	5.29	5.41
E	0.255	0.262	0.265	6.48	6.65	6.73
F	0.027	0.031	0.033	0.69	0.80	0.84
G	0.087	0.090	0.093	2.21	2.28	2.36
H	0.085	0.092	0.095	2.16	2.33	2.41
I	0.176	0.179	0.184	4.47	4.55	4.67
J	0.018	0.020	0.023	0.46	0.51	0.58
K	0.038	0.040	0.044	0.97	1.02	1.12
L	0.018	0.020	0.023	0.46	0.51	0.58
M	0.000	0.000	0.004	0.00	0.00	0.10
N	0.021	0.026	0.027	0.53	0.67	0.69
O	0°	0°	5°	0°	0°	5°
P	0.042	0.047	0.052	1.06	1.20	1.32
Q	0.034	0.039	0.044	0.86	1.00	1.11

Part Selector

Part Number	Voltage 800V	Gate Sensitivity		Type	Package
		I-II-III	IV		
QS8004DH2	X	10 mA	—	OV TRIAC	TO-252 D-PAK
QS8004DH4	X	35 mA	—	OV TRIAC	TO-252 D-PAK

Part Number and Marking

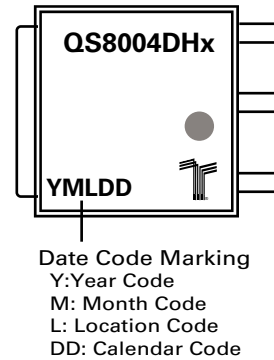
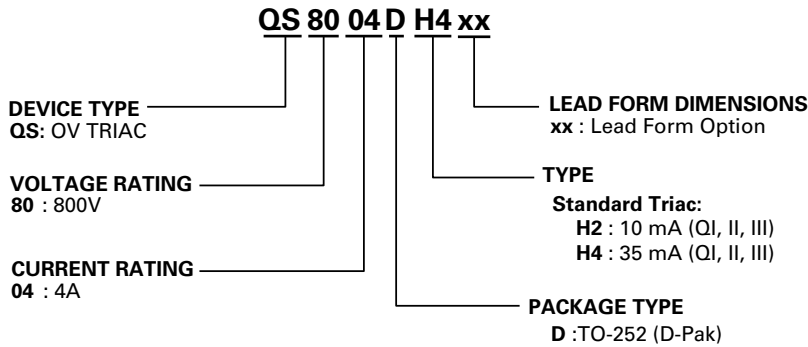

Packing Options

Part Number	Marking	Weight	Packing Mode	M.O.Q.
QS8004DHxTP	QS8004DHx	0.335 g	Tube Pack	750 (75 per tube)
QS8004DHxRP	QS8004DHx	0.335 g	EmbossedCarrier	2500