

ON Semiconductor

Is Now

onsemi™

To learn more about onsemi™, please visit our website at
www.onsemi.com

onsemi and **onsemi** and other names, marks, and brands are registered and/or common law trademarks of Semiconductor Components Industries, LLC dba "**onsemi**" or its affiliates and/or subsidiaries in the United States and/or other countries. **onsemi** owns the rights to a number of patents, trademarks, copyrights, trade secrets, and other intellectual property. A listing of **onsemi** product/patent coverage may be accessed at www.onsemi.com/site/pdf/Patent-Marking.pdf. **onsemi** reserves the right to make changes at any time to any products or information herein, without notice. The information herein is provided "as-is" and **onsemi** makes no warranty, representation or guarantee regarding the accuracy of the information, product features, availability, functionality, or suitability of its products for any particular purpose, nor does **onsemi** assume any liability arising out of the application or use of any product or circuit, and specifically disclaims any and all liability, including without limitation special, consequential or incidental damages. Buyer is responsible for its products and applications using **onsemi** products, including compliance with all laws, regulations and safety requirements or standards, regardless of any support or applications information provided by **onsemi**. "Typical" parameters which may be provided in **onsemi** data sheets and/or specifications can and do vary in different applications and actual performance may vary over time. All operating parameters, including "Typicals" must be validated for each customer application by customer's technical experts. **onsemi** does not convey any license under any of its intellectual property rights nor the rights of others. **onsemi** products are not designed, intended, or authorized for use as a critical component in life support systems or any FDA Class 3 medical devices or medical devices with a same or similar classification in a foreign jurisdiction or any devices intended for implantation in the human body. Should Buyer purchase or use **onsemi** products for any such unintended or unauthorized application, Buyer shall indemnify and hold **onsemi** and its officers, employees, subsidiaries, affiliates, and distributors harmless against all claims, costs, damages, and expenses, and reasonable attorney fees arising out of, directly or indirectly, any claim of personal injury or death associated with such unintended or unauthorized use, even if such claim alleges that **onsemi** was negligent regarding the design or manufacture of the part. **onsemi** is an Equal Opportunity/Affirmative Action Employer. This literature is subject to all applicable copyright laws and is not for resale in any manner. Other names and brands may be claimed as the property of others.



ON Semiconductor®

QSE773 Sidelooker Pin Photodiode

Features

- Daylight filter
- Sidelooker package
- Pin photodiode
- Wide reception angle, 120°
- Chip size = 0.107 sq. inches (2.71 sq. mm)

Description

The QSE773 is a plastic silicon pin photodiode in a sidelooker package.

Package Dimensions

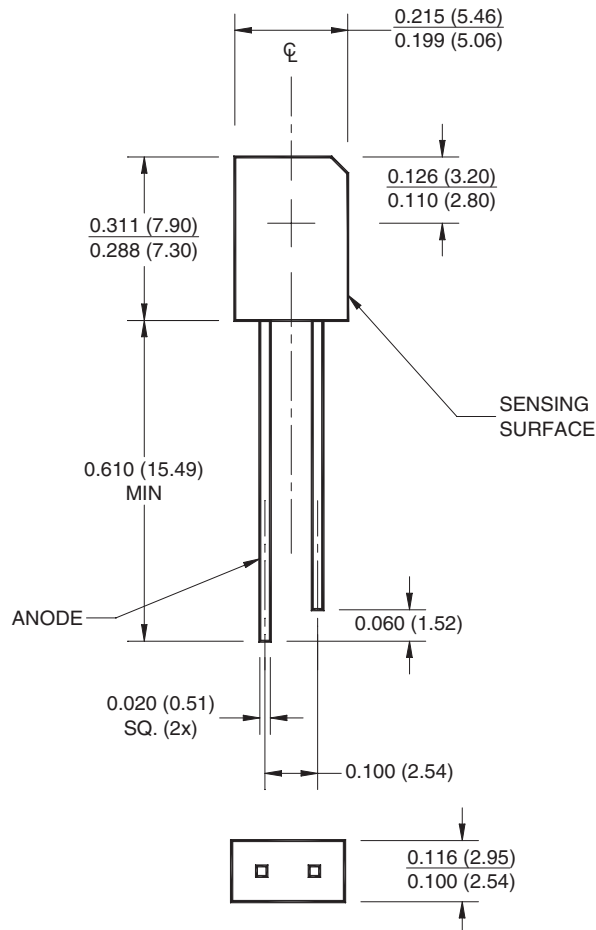

Schematic

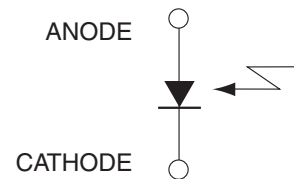

Notes:

1. Dimensions for all drawings are in inches (mm).
2. Tolerance of ± 0.010 (0.25) on all non-nominal dimensions unless otherwise specified.

Absolute Maximum Ratings ($T_A = 25^\circ\text{C}$ unless otherwise noted)

Stresses exceeding the absolute maximum ratings may damage the device. The device may not function or be operable above the recommended operating conditions and stressing the parts to these levels is not recommended. In addition, extended exposure to stresses above the recommended operating conditions may affect device reliability. The absolute maximum ratings are stress ratings only.

Symbol	Parameters	Value	Units
T_{OPR}	Operating Temperature	-40 to +85	$^\circ\text{C}$
T_{STG}	Storage Temperature	-40 to +85	$^\circ\text{C}$
$T_{\text{SOL-I}}$	Soldering Temperature (Iron) ⁽⁴⁾⁽⁵⁾⁽⁶⁾⁽⁷⁾	240 for 5 sec.	$^\circ\text{C}$
$T_{\text{SOL-F}}$	Soldering Temperature (Flow) ⁽⁴⁾⁽⁵⁾⁽⁷⁾	260 for 10 sec	$^\circ\text{C}$
V_{R}	Reverse Voltage	32	V
P_{D}	Power Dissipation ⁽³⁾	150	mW

Notes:

- Derate power dissipation linearly 2.50mW/ $^\circ\text{C}$ above 25 $^\circ\text{C}$.
- RMA flux is recommended.
- Methanol or Isopropyl alcohols are recommended as cleaning agents.
- Soldering iron tip 1/16" (1.6 mm) from housing.
- As long as leads are not under any stress or spring tension.

Electrical Characteristics ($T_A = 25^\circ\text{C}$)

Symbol	Parameter	Test Conditions	Min.	Typ.	Max.	Units
V_{R}	Reverse Voltage	$I_{\text{R}} = 0.1\text{mA}$, $E_{\text{e}} = 0\text{mW}/\text{cm}^2$	32			V
$I_{\text{R(D)}}$	Dark Reverse Current	$V_{\text{R}} = 10\text{V}$, $E_{\text{e}} = 0\text{mW}/\text{cm}^2$			30	nA
λ_{PK}	Peak Sensitivity	$V_{\text{R}} = 5\text{V}$		940		nm
Θ	Reception Angle at 1/2 Power			± 60		$^\circ$
I_{PH}	Photo Current ⁽⁸⁾	$E_{\text{e}} = 1.0\text{mW}/\text{cm}^2$, $V_{\text{R}} = 5\text{V}$	30			μA
I_{SC}	Short Circuit Current ⁽⁸⁾	$E_{\text{e}} = 1.0\text{mW}/\text{cm}^2$		18		μA
C	Capacitance	$V_{\text{R}} = 3\text{V}$		25		pF
t_{r}	Rise Time	$V_{\text{R}} = 5\text{V}$, $R_{\text{L}} = 1\text{k}\Omega$		50		ns
t_{f}	Fall Time	$V_{\text{R}} = 5\text{V}$, $R_{\text{L}} = 1\text{k}\Omega$		50		ns

Notes:

- Light source is an GaAs LED which has a peak emission wavelength of 940nm.
- All measurements made under pulse conditions.

Typical Performance Curves

Fig. 1 Relative Spectral Sensitivity vs. Wavelength

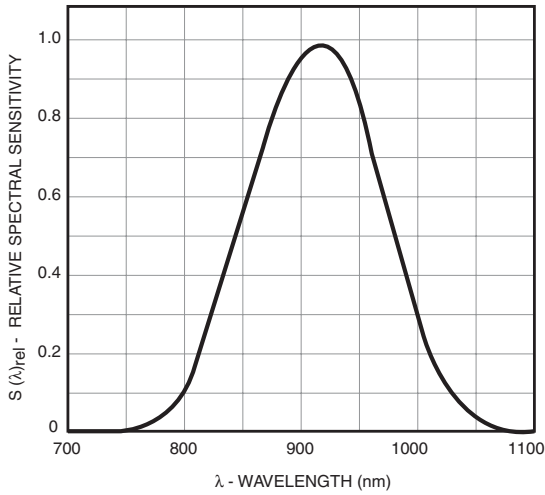

Fig. 2 Short Circuit Current vs. Irradiance

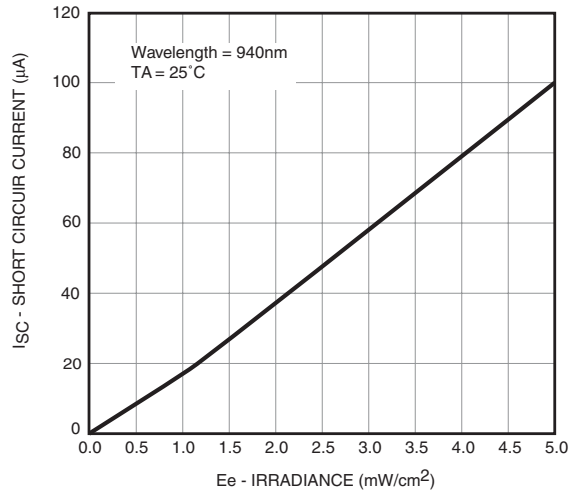

Fig. 3 Short Circuit Current vs. Temperature

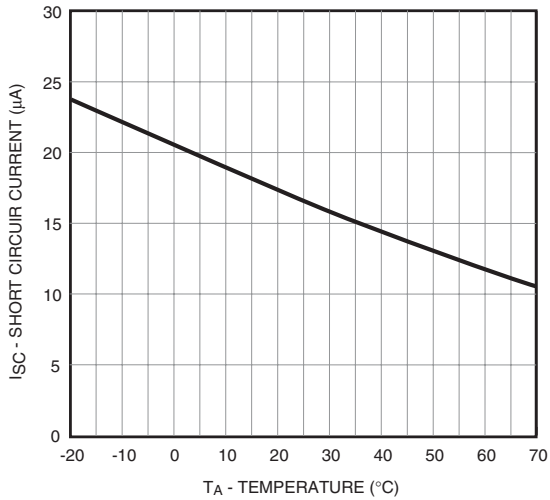

Fig. 4 Capacitance vs. Reverse Voltage

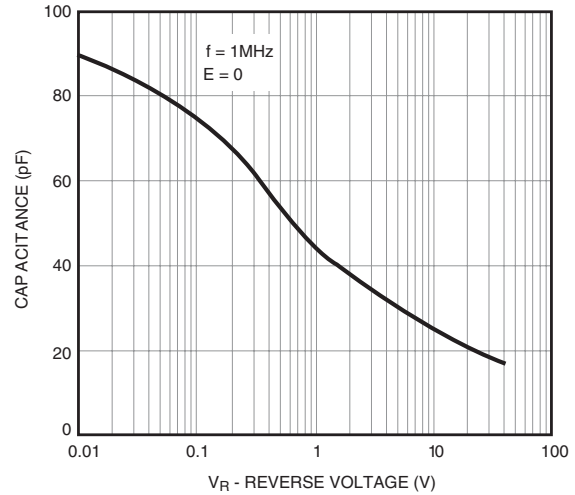

Fig. 5 Dark Current vs. Temperature

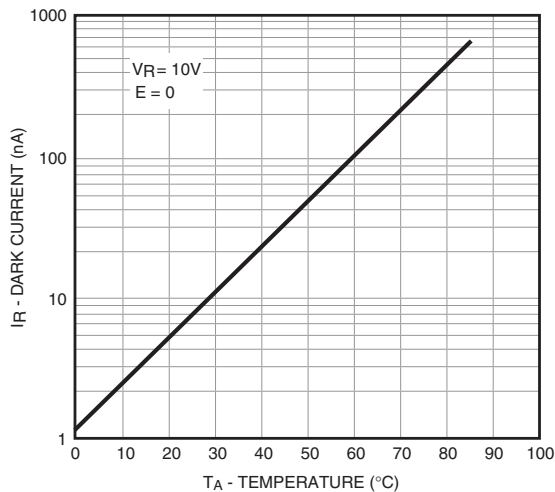

Fig. 6 Dark Current vs. Reverse Voltage

