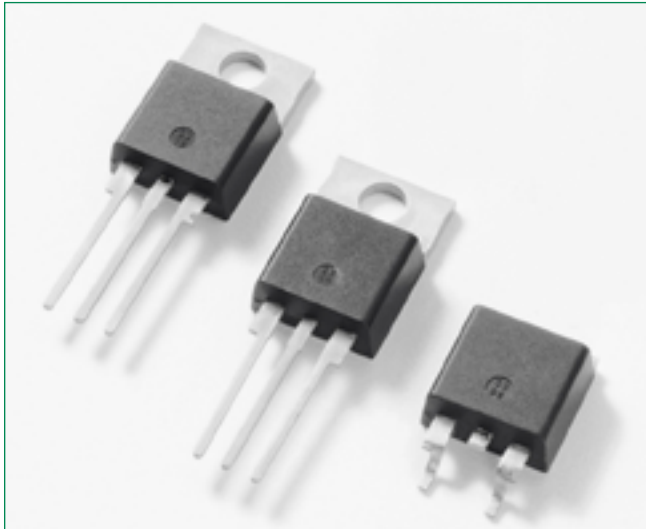

QVxx12xHx Series

12 A High Temperature Alternistor Triacs

HF RoHS

Agency Approvals and Environmental

Environmental Approvals	Agency Approvals
HF RoHS	 L Package: E71639

Product Summary

Symbol	Value	Unit
$I_{T(RMS)}$	12	A
V_{DRM}/V_{RRM}	600	V
$I_{GT(Q1)}$	35 or 50	mA

Schematic Symbol

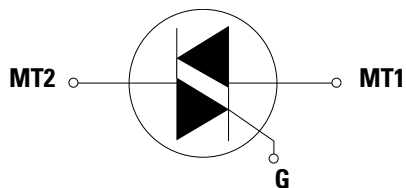

Description

This 12 A high temperature Alternistor TRIAC, offered in TO-220AB, TO-220 isolated, and TO-263 packages, has 150 °C maximum junction temperature (T_j) and 153 A ITSM (60 Hz).

This series enables easier thermal management and higher surge handling capability in AC power control applications such as heater control, motor speed control, lighting controls, and static switching relays. Alternistor TRIAC operates in quadrants I, II, and III, and offers high performance in applications requiring high commutation capability.

Features & Benefits

- High T_j of 150°C
- Voltage capability of 600 V
- Surge capability of 153 A at 60Hz half cycle
- Mechanically and thermally robust TO-220 clip-attach assembly
- Internally-isolated TO-220 package
- Halogen-free and RoHS-compliant
- High dv/dt up to 1000 V/μs

Applications

TRIAC is an excellent AC switch in applications such as heating, lighting, and motor speed controls.

Typical applications are:

- Heater control such as coffee brewer, tankless water heater, and infrared heater
- AC solid-state relays
- Light dimmers including incandescent and LED lighting
- Motor speed control in kitchen appliances, power tools, home/brow/white goods and light industrial applications such as compressor motor control

Alternistor TRIAC is used with high inductive loads requiring high commutation capability. Internally isolated packages offer better heat sinking with higher isolation voltage.

QVxx12xHx Series

12 A High Temperature Alternistor Triacs

Maximum Ratings – Alternistor Triac (3 Quadrants)

Symbol	Characteristic	Conditions	Value	Unit
$I_{T(RMS)}$	Rms On-State Current (Full Sine Wave)	QVxx12LHy $T_C = 120\text{ }^\circ\text{C}$	12	A
		QVxx12RHy / QVxx12NHy $T_C = 135\text{ }^\circ\text{C}$		
I_{TSM}	Non-Repetitive Surge Peak On-State Current (Single Half Cycle, T_J Initial = $25\text{ }^\circ\text{C}$)	$f = 50\text{ Hz}$, $t = 20\text{ ms}$	140	A
		$f = 60\text{ Hz}$, $t = 16.7\text{ ms}$	153	
I^2t	I^2t Value For Fusing	$t_p = 8.3\text{ ms}$	97	A^2s
di/dt	Critical Rate Of Rise Of On-State Current	$f = 60\text{ Hz}$, $T_J = 150\text{ }^\circ\text{C}$	100	$\text{A}/\mu\text{s}$
I_{GTM}	Peak Gate Trigger Current	$t_p \leq 10\text{ }\mu\text{s}$, $I_{GT} \leq I_{GTM}$, $T_J = 150\text{ }^\circ\text{C}$	4	A
$P_{G(AV)}$	Average Gate Power Dissipation	$T_J = 150\text{ }^\circ\text{C}$	0.5	W
T_{stg}	Storage Temperature Range	-	-40 to 150	$^\circ\text{C}$
T_{VJ}	Operating Junction Temperature Range	-	-40 to 150	$^\circ\text{C}$
V_{DSM}/V_{RSM}	Non Repetitive Surge Peak Off-State Voltage	pulse width = $100\text{ }\mu\text{s}$; $V_{DRM} = 600\text{ V}$	$V_{DSM}/V_{RSM} + 100$	V

xx = voltage/10; y = sensitivity

Thermal Characteristics

Symbol	Characteristic	Value	Unit
R_{thJC}	Thermal Resistance, Junction-To-Case (AC)	QVxx12RHy / QVxx12NHy	0.9
		QVxx12LHy	1.85

Electrical Characteristics ($T_J = 25\text{ }^\circ\text{C}$, unless otherwise specified) – Alternistor Triac (3 Quadrants)

Symbol	Description	Conditions	QVxx12xH4			QVxx12xH5			Unit	
			Min	Typ	Max	Min	Typ	Max		
I_{GT}	DC Gate Trigger Current	$V_D = 12\text{ V}$ $R_L = 60\Omega$	I – II – III	-	-	35	-	-	50	mA
V_{GT}	DC Gate Trigger Voltage		I – II – III	-	-	1.2	-	-	1.2	V
V_{GD}	Gate Non-trigger Voltage	$V_D = V_{DRM}$ $R_L = 3.3\text{ k}\Omega$ $T_J = 150\text{ }^\circ\text{C}$	I – II – III	0.15	-	-	0.15	-	-	V
I_H	Holding Current	$I_T = 100\text{ mA}$	-	-	50	-	-	50	mA	
dv/dt	Critical Rate-of-rise of Off-stage Voltage	$V_D = V_{DRM}$ Gate Open $T_J = 150\text{ }^\circ\text{C}$	-	500	-	-	750	-	-	$\text{V}/\mu\text{s}$
		$V_D = 2/3 V_{DRM}$ Gate Open $T_J = 150\text{ }^\circ\text{C}$	-	1000	-	-	1000	-	-	
$(dv/dt)_c$	-	$(di/dt)_c = 8.6\text{ A/ms}$ $T_J = 150\text{ }^\circ\text{C}$	-	50	-	-	50	-	-	$\text{V}/\mu\text{s}$
t_{gt}	Turn-on Time	$I_G = 2 \times I_{GT}$ $PW = 15\text{ }\mu\text{s}$ $I_T = 22.6\text{ A(pk)}$	I	-	1	-	-	1	-	μs
			II	-	2	-	-	2	-	
			III	-	7	-	-	10	-	

xx = voltage/10;
x = sensitivity

Static Characteristics

Symbol	Description	Conditions	Maximum Value	Unit
V_{TM}	Peak On-state Voltage	$I_T = 17\text{ A}$ $t_p = 380\text{ }\mu\text{s}$	1.60	V
I_{DRM}/I_{RRM}	Off-state Current, Peak Repetitive	$V_D = V_{DRM}/V_{RRM}$ $T_J = 25\text{ }^\circ\text{C}$	5	μA
		$V_D = V_{DRM}/V_{RRM}$ $T_J = 150\text{ }^\circ\text{C}$, $V_{DRM} = 600\text{ V}$	4	mA
V_{TO}	Threshold Voltage	$T_J = 150\text{ }^\circ\text{C}$	0.85	V
R_D	Dynamic Resistance	$T_J = 150\text{ }^\circ\text{C}$	23	$\text{m}\Omega$

QVxx12xHx Series

12 A High Temperature Alternistor Triacs

Performance Curves

Figure 1:
Definition of Quadrants

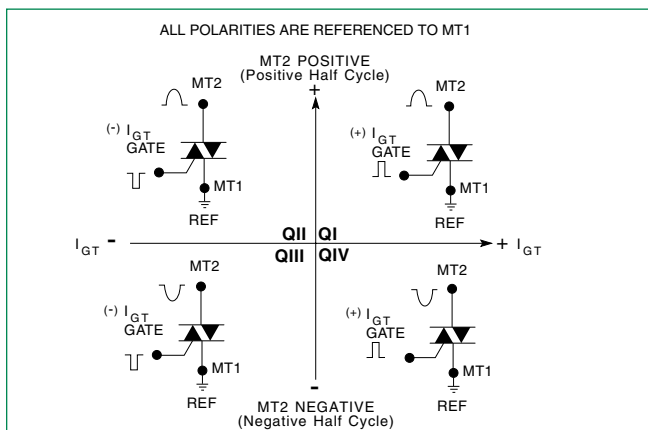

Note: Alternistors will not operate in QIV

Figure 2:
Normalized DC Gate Trigger Current for All Quadrants vs. Junction Temperature

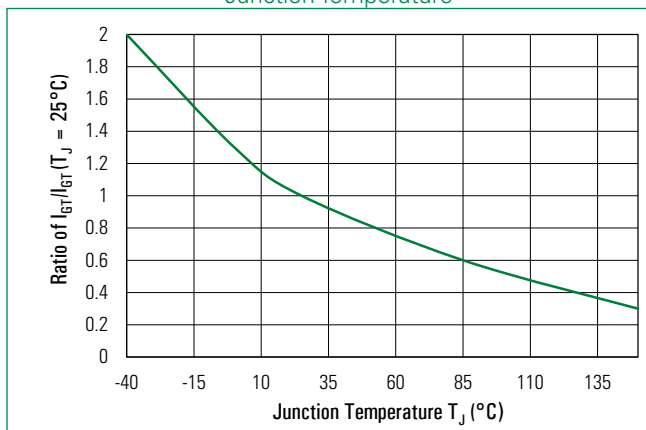

Figure 3:
Normalized DC Holding Current vs. Junction Temperature

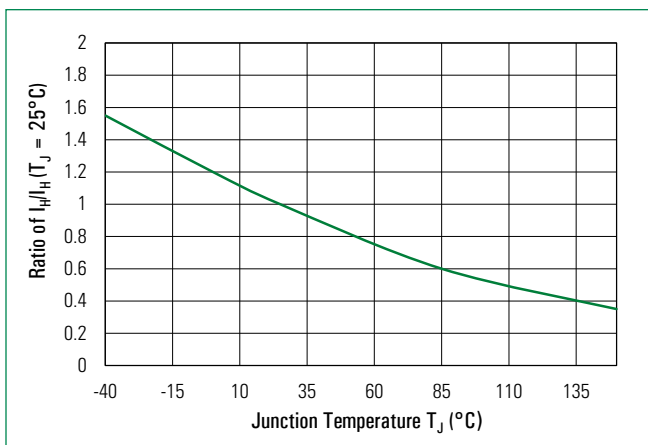

Figure 4:
Normalized DC Gate Trigger Voltage for All Quadrants vs. Junction Temperature

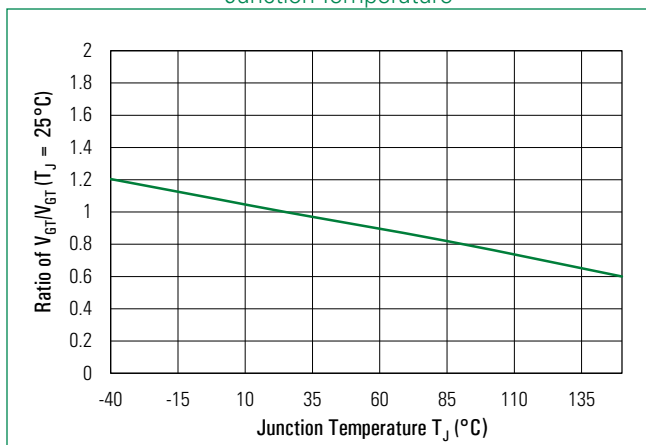

Figure 5:
Power Dissipation (Typical) vs. RMS On-State Current

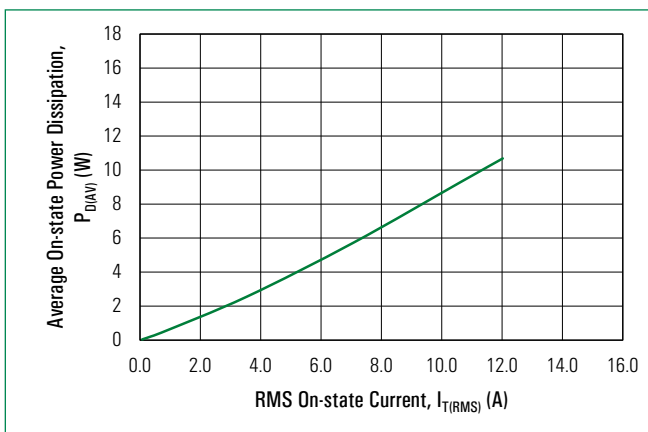
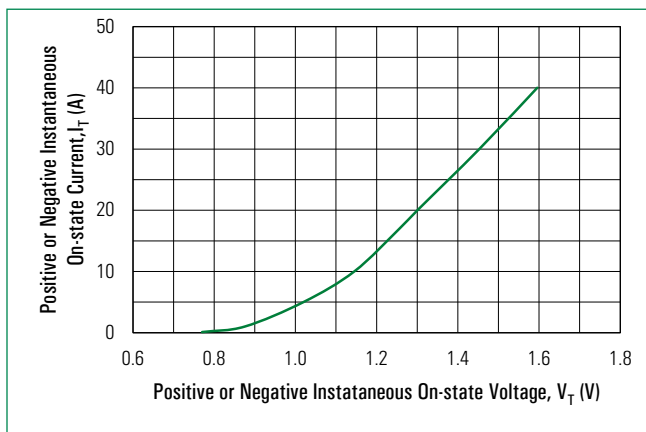

Figure 6:
On-State Current vs. On-State Voltage (Typical)



QVxx12xHx Series

12 A High Temperature Alternistor Triacs

Figure 7:
Maximum Allowable Case Temperature vs. RMS On-State Current

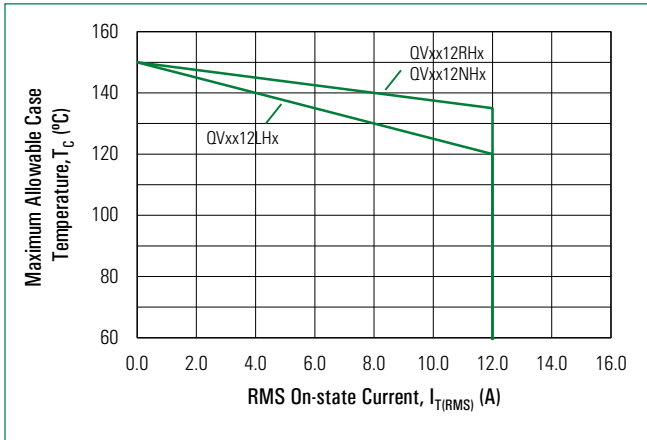
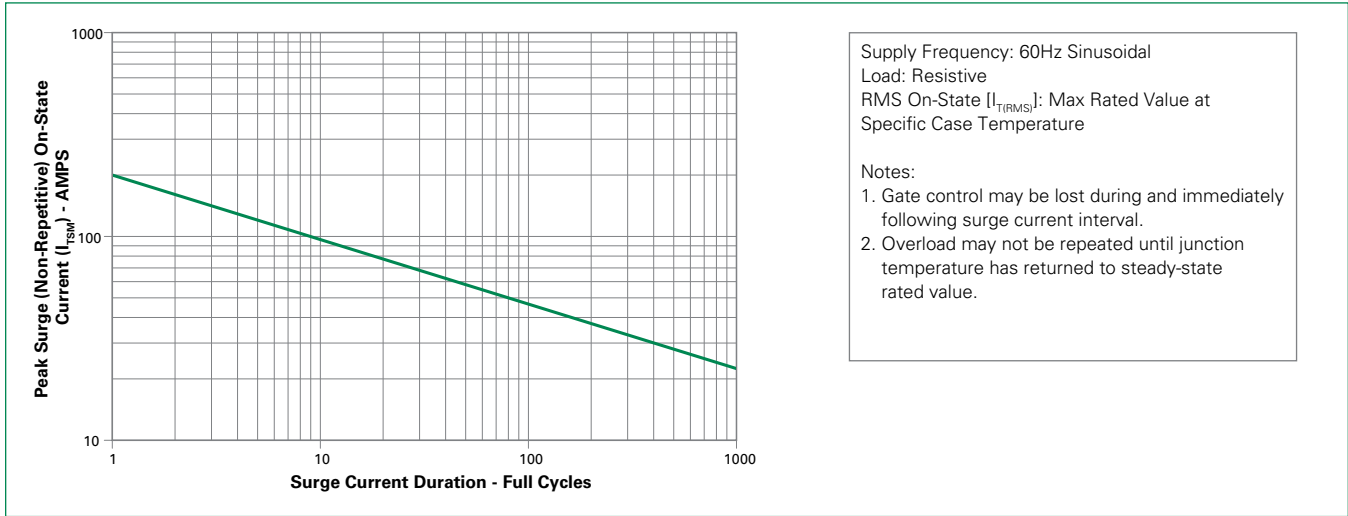
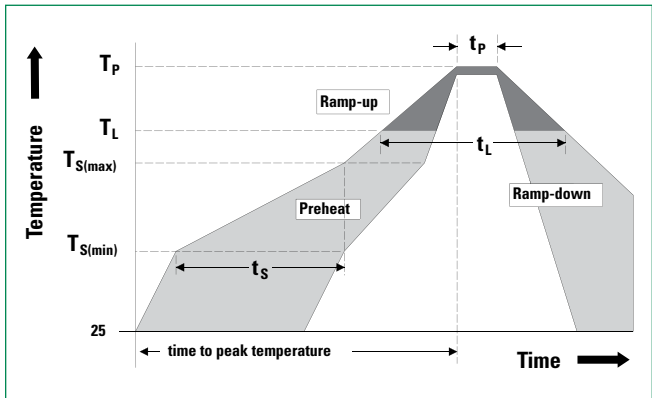

Figure 8: Surge Peak On-State Current vs. Number of Cycles



Soldering Parameters

Reflow Condition		Pb – Free assembly
Pre Heat	- Temperature Min ($T_{s(min)}$)	150°C
	- Temperature Max ($T_{s(max)}$)	200°C
	- Time (min to max) (t_s)	60 – 180 s
Average ramp up rate (Liquidus Temp) (T_L) to peak		5°C/s (Max)
$T_{S(Max)}$ to T_L - Ramp-up Rate		5°C/s (Max)
Reflow	- Temperature (T_L) (Liquidus)	217°C
	- Time (t_r)	60 – 150 seconds
Peak Temperature (T_p)		260 °C (± 5)
Time within 5°C of actual peak Temperature (t_p)		20 – 40 s
Ramp-down Rate		5°C/s (Max)
Time 25°C to peak Temperature (T_p)		8 minutes Max.
Do not exceed		280°C



QVxx12xHx Series

12 A High Temperature Alternistor Triacs

Physical Specifications

Terminal Finish	100% Matte Tin-plated
Body Material	UL Recognized compound meeting flammability rating 94V-0
Terminal Material	Copper Alloy

Design Considerations

Careful selection of the correct component for the application's operating parameters and environment will go a long way toward extending the operating life of the Thyristor. Good design practice should limit the maximum continuous current through the main terminals to 75% of the component rating. Other ways to ensure long life for a power discrete semiconductor are proper heat sinking and selection of voltage ratings for worst case conditions. Overheating, overvoltage (including dv/dt), and surge currents are the main killers of semiconductors. Correct mounting, soldering, and forming of the leads also help protect against component damage.

Environmental Specifications

Test	Specifications and Conditions
AC Blocking	MIL-STD-750, M-1040, Cond A Applied Peak AC voltage @ 150°C for 1008 hours
Temperature Cycling	MIL-STD-750, M-1051, 1000 cycles; -55°C to +150°C; 15-min dwell time
Temperature/Humidity	EIA / JEDEC, JESD22-A101, 1008 hours; 160V - DC: 85°C; 85% rel humidity
Resistance to Solder Heat	MIL-STD-750 Method 2031
Solderability	ANSI/J-STD-002, category 3, Test A
Lead Bend	MIL-STD-750, M-2036 Cond E
Moisture Sensitivity Level	Level 1, JEDEC-J-STD-020
UHAST	JESD22A-118, 96 hrs, 130°C/ 85% RH
IOL	MIL-STD-750 Method 1037

Dimensions - TO-220AB (R-Package) - Non-Isolated Mounting Tab Common with Center Lead

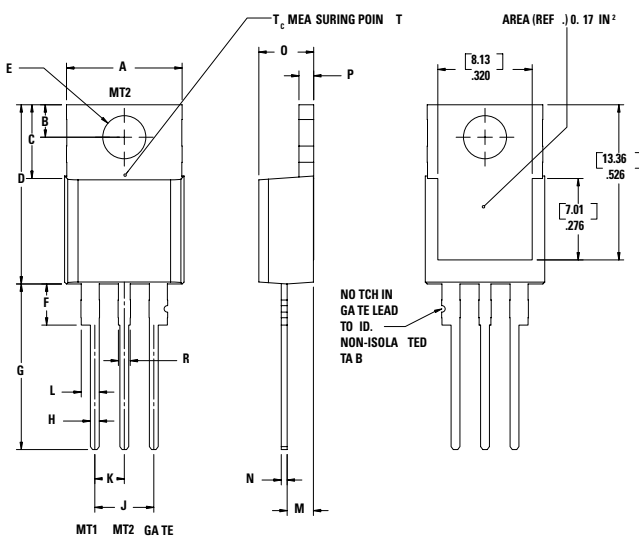

Note: Maximum torque to be applied to mounting tab is 8 in.-lbs. (0.904 Nm).

Dimension	Inches		Millimeters	
	Min	Max	Min	Max
A	0.380	0.420	9.65	10.67
B	0.105	0.115	2.66	2.92
C	0.230	0.250	5.84	6.35
D	0.590	0.620	14.99	15.75
E	0.142	0.147	3.61	3.73
F	0.110	0.130	2.79	3.30
G	0.540	0.575	13.72	14.61
H	0.025	0.035	0.64	0.89
J	0.195	0.205	4.95	5.21
K	0.095	0.105	2.41	2.67
L	0.060	0.075	1.52	1.91
M	0.085	0.095	2.16	2.41
N	0.018	0.024	0.46	0.61
O	0.178	0.188	4.52	4.78
P	0.045	0.060	1.14	1.52
R	0.038	0.048	0.97	1.22