

# Features

# Reference Design

- Complete isolated solution for CAN bus
- Contains galvanically-isolated CAN transceiver ISO1042
- Contains R1SX-3.305/H - 3.3V to 5V 1W DC-DC converter with 3kVDC isolation
- Up to 5Mbit data rate in CAN FD mode
- Input and output test points
- Meets ISO11898-2 (2016) standard

## R-REF03-CAN1

### Description

The R-REF03-CAN1 Reference Board demonstrates the ISO1042 isolated CAN transceiver supplied by the R1SX-3.305/H isolated DC/DC converter. To supply the reference board only one 3.3V external supply is required. The green LED indicates the presence of the VCC2 supply on the secondary (CAN bus) side. The reference board allows designers to quickly develop and analyze isolated systems.

The reference board is pre-configured with a “split” termination network (R2 and R4) with a common-mode capacitance and additional caps (C7, C8 and C9) on the CAN bus for protection. It also includes an option to populate a 120-Ω resistor R3 which can be used with the EVM as a terminated line end (CAN is defined for 120Ω impedance twisted pair cable). Protection components like TVS diodes (D1) and common mode (CM) choke (L1) are also provided with bypass paths if necessary. Using these options, the customer is allowed installation of the desired components.

The output of the R1SX-3.305/H (U2) is used to supply the secondary (CAN bus) side of the digital isolator U1 and the green LED (LED1) which indicates the presence of the voltage on VCC2. VCC2 is loaded with a 120Ω resistor R7, too, to keep the VCC2 safely below 5.3V. Since the reference board internally consumes about 80mA from the output of the U2, a user can use about 120mA to supply circuits outside of this reference board through connector J2-1 or test point TP10.

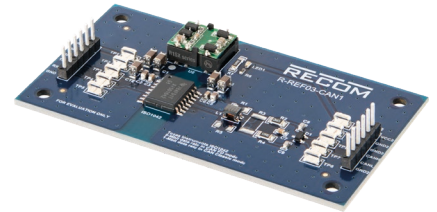

### R-REF03-CAN1 Top view

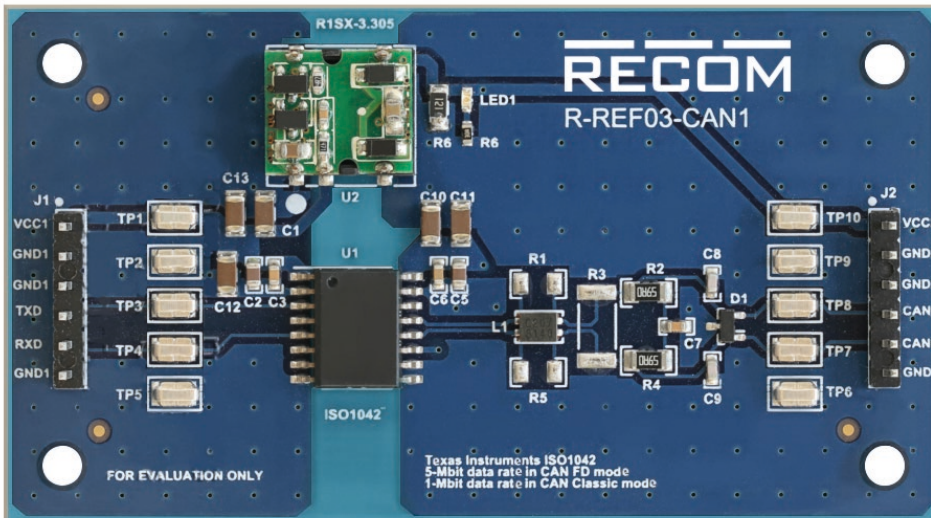

#### Caution:

ESD sensitive. Always follow ESD preventative procedures when handling the product!

**Specifications** (measured @ Ta= 25°C, full load after warm up unless otherwise stated)

**BASIC CHARACTERISTICS of the R1SX-3.305/H**

Parameter	Condition			Min.	Typ.	Max.
Input Voltage Range				±10.0%		
Internal Operating Frequency				20kHz	60kHz	100kHz
Output Ripple and Noise <sup>(1)</sup>	20MHz BW					100mVp-p
Output Accuracy						±5.0%
Isolation Voltage	I/P to O/P	with suffix "/H"	tested for 1 second rated for 1 minute			3kVDC 1.5kVAC
Isolation Resistance				10GΩ		
Isolation Capacitance						70pF
Leakage Current						3μA
Operating Temperature Range				-40°C to +100°C		
Operating Altitude						5000m

**Notes:**

Note1: Measurements are made with a 0.1μF MLCC across output. (low ESR)

**Footprint Details of R1SX (mm)**

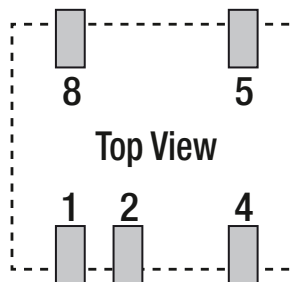

**Pin Connection**

Pin #	Single
1	-Vin
2	+Vin
4	-Vout
5	+Vout
8	NC

NC= no connection

**Basic Specification of the ISO1042**

The ISO1042 device is a galvanically-isolated controller area network (CAN) transceiver that meets the specifications of the ISO11898-2 (2016) standard. The device supports up to 5-Mbps data rate in CAN FD mode allowing much faster transfer of payload compared to classic CAN. This device uses a silicon dioxide (SiO<sub>2</sub>) insulation barrier with a withstand voltage of 5000 VRMS. Used in conjunction with isolated power supplies like R1SX from RECOM, the device prevents noise currents on a data bus or other circuits from entering the local ground and interfering with or damaging sensitive circuitry.

ISO1042 accepts 1.8V, 2.5V, 3.3V or 5.5V supply voltage on the primary side (VCC1) and 5V on the secondary (VCC2).

For more details about the ISO1042 please visit [www.ti.com/product/iso1042](http://www.ti.com/product/iso1042)

**Notes:**

Note2: The reference board may contain pre-production version of the ISO1042. This pre-production version part number is XISO1042 and this part number is printed on the IC. If your board is populated with the XISO1042, the prototype device waiver from Texas Instruments (included at the end of this document) is applicable.

Specifications (measured @ Ta= 25°C, full load after warm up unless otherwise stated)

### Typical Switching Waveforms

Input and output waveforms of the reference board for a 5Mbit signal

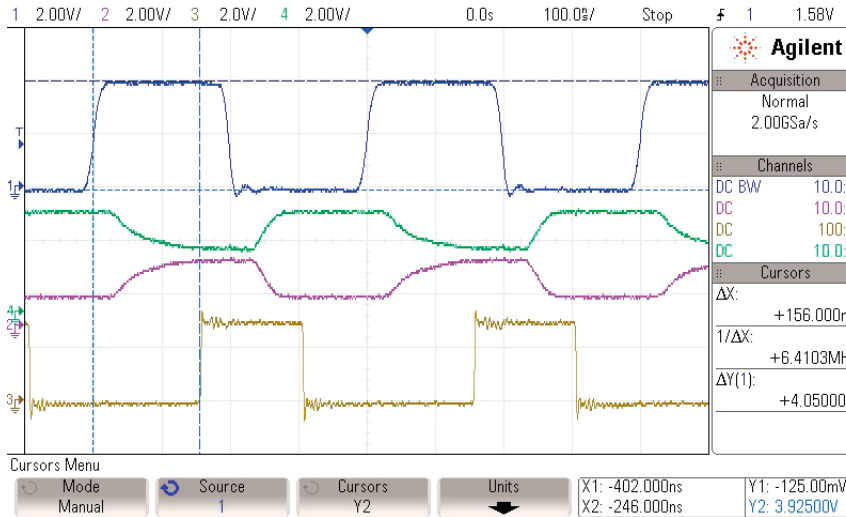

CH1 - TXD  
CH2 - CANL  
CH3 - RXD  
CH4 - CANH

### Quick Start Guide

- Apply 3.3V to VCC1/GND1 and observe 5V on the VCC2/GND2. The green LED on the board should light up
- Inject test signal up to 5-Mbit into the TXD input pin (TXD/GND1) using a signal generator or other source
- Check the CANH and CANL signals with a scope on the secondary side (CANH/GND2 and CANL/GND2)
- Check the RXD signal with a scope on the primary side (RXD/GND1)
- Turn off the signal generator
- Turn off the 3.3V supply. The LED should turn off

### Basic Test Setup

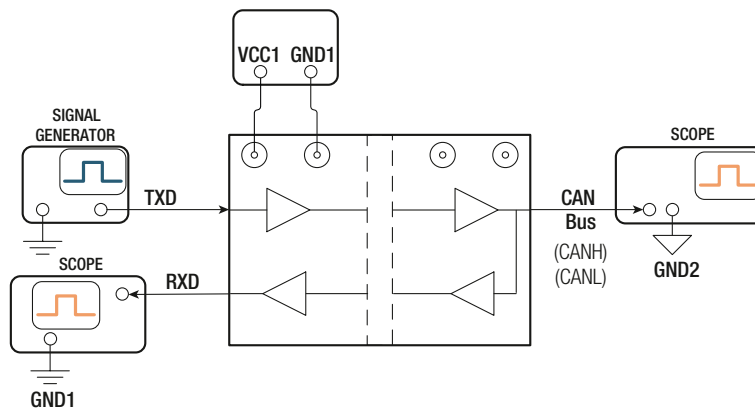

### Connector Description

#### Con1

Pin	Name	Description	Test Point
1	VCC1	Primary Supply 3.3V	TP1
2	GND1	Primary Ground	TP2
3	GND1	Primary Ground	
4	TXD	CAN transmit data input	TP3
5	RXD	CAN receive data output	TP4
6	GND1	Primary Ground	TP5

#### Con2

Pin	Name	Description	Test Point
1	VCC2	Secondary Supply 5V	TP10
2	GND2	Secondary Ground	TP9
3	GND2	Secondary Ground	
4	CANH	High-level CAN bus line	TP8
5	CANL	Low-level CAN bus line	TP7
6	GND2	Secondary Ground	TP6

Specifications (measured @ Ta= 25°C, full load after warm up unless otherwise stated)

Schematic

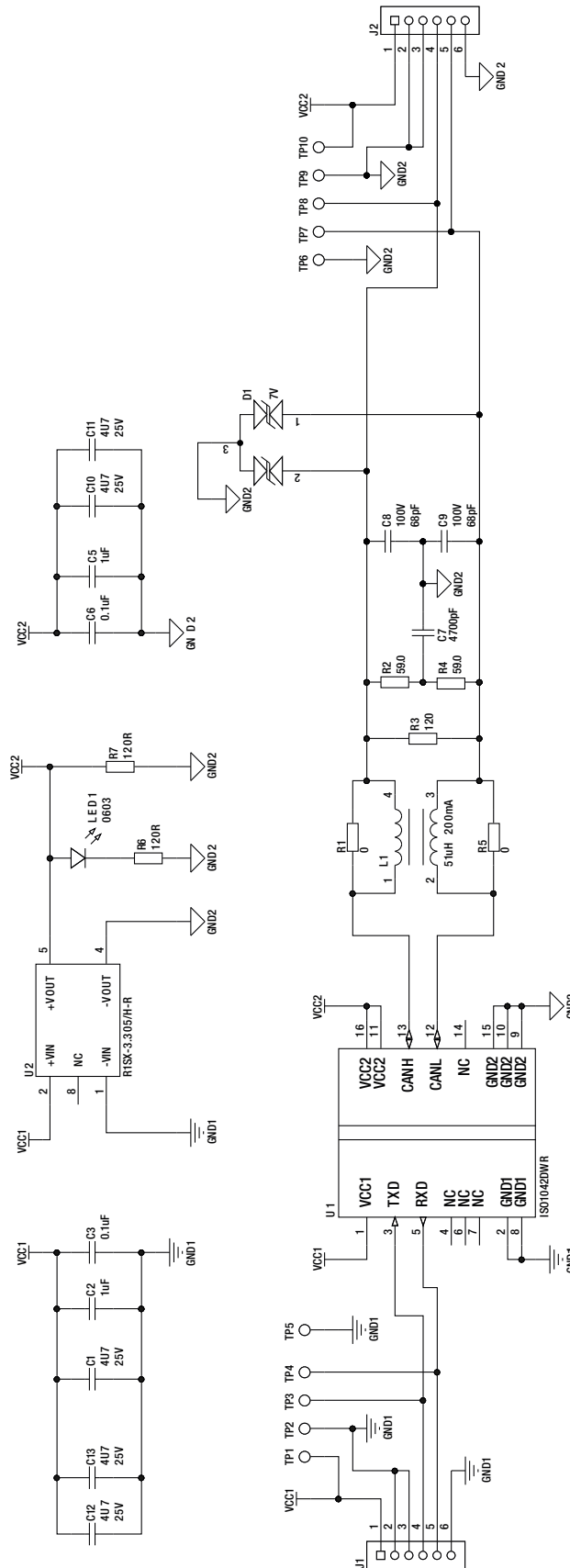

Specifications (measured @ Ta= 25°C, full load after warm up unless otherwise stated)

## DIMENSION AND PHYSICAL CHARACTERISTICS

Parameter	Type	Value
Dimension (LxWxH)		81.28 x 44.96 x 18.0mm
Weight		18.0g typ.

## Layout

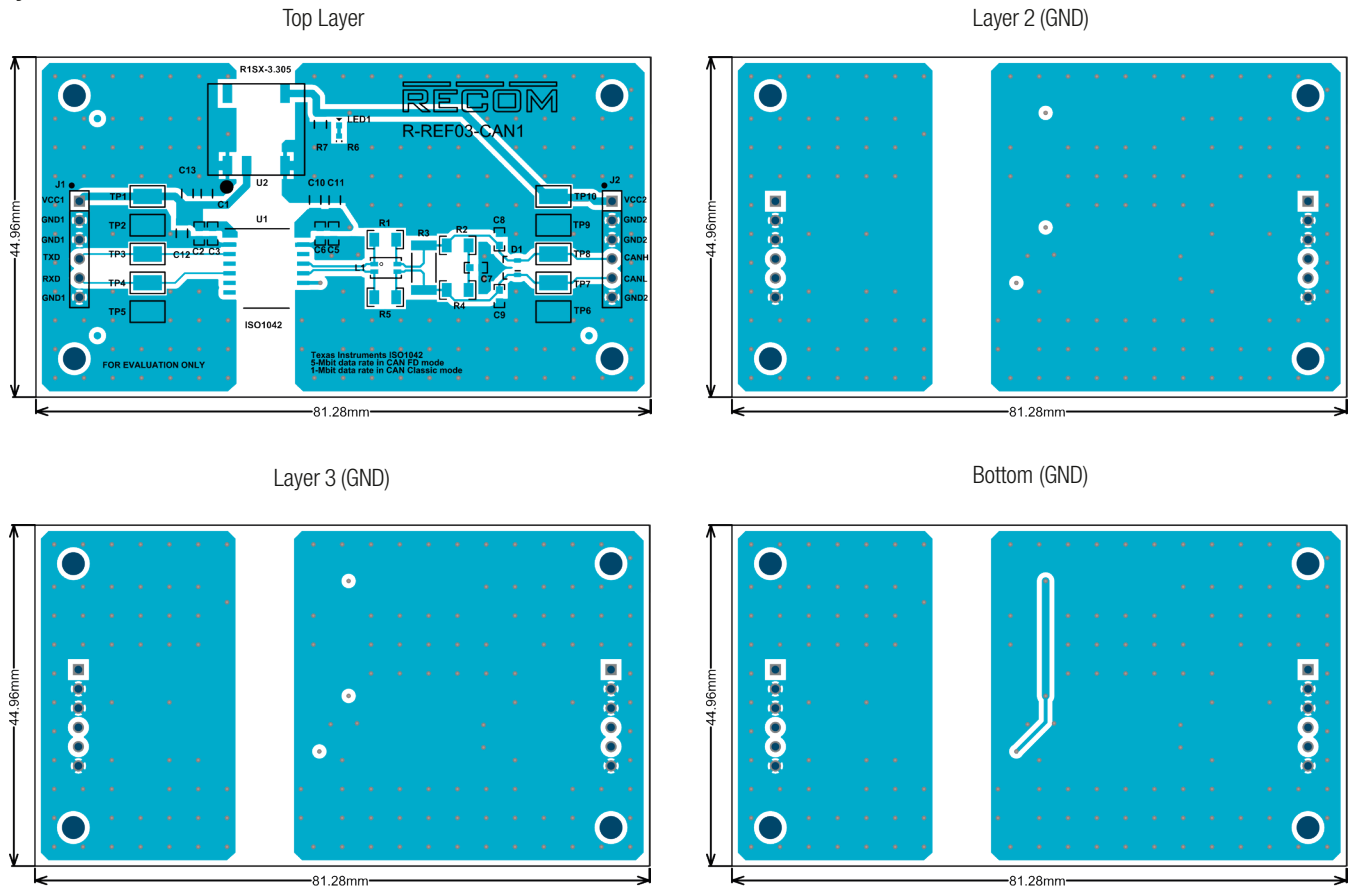

### Notes:

Note3: Visit [www.recom-power.com/eval-ref-boards](http://www.recom-power.com/eval-ref-boards) to download the Gerber files

## BOM

Comp.	Description	Manufacturer Part Number	Manufacturer	Qty.
U1	Isolated CAN transceiver	ISO1042DWR or XISO1042DWR	TI	1
U2	Isolated DC/DC converter 3.3V to 5V 3kVDC	R1SX-3.305 /H	RECOM	1
L1	Coupled inductor, 51 $\mu$ H, 0.2 A, 0.7 ohm, SMD	ACT1210-510-2P-TL00	TDK	1
R6	RES, 120, 1%, 0.1 W, 0603		Yageo	1
R1, R5	RES, 0, 5%, 0.25 W, 1206		Yageo	not mounted
R3	RES, 120, 1%, 1 W, 2512		Yageo	not mounted
R2, R4	RES, 59.0, 1%, 0.25 W, 1206		Yageo	2
R7	RES, 120, 1%, 0.25 W, 1206		Yageo	1
C7	CAP, CERM, 4700 pF, 50 V, +/- 10%, X7R, 0603		Murata	1

continued on next page