

# 10/100BASE-T TRANSFORMER MODULES

Industrial grade



- Compliant with IEEE 802.3 standards
- 350µH OCL with 8mA DC bias at 100KHz 100mV
- Lead finish: Pure tin
- Moisture Sensitivity Level: 1

## Electrical Specifications @ 25°C - Operating temperature : - 40°C to + 85°C

Part Number	Insertion Loss (dB MAX)	Return Loss (dB MIN)				Crosstalk (dB MIN)			DM to CM Rejection Ratio (dB MAX)			Dielectric Withstanding Voltage @60s (Vrms MIN)
		0.1-100 MHz	30 MHz	50 MHz	60 MHz	80 MHz	30 MHz	60 MHz	80 MHz	30 MHz	60 MHz	
R1001NL	-1.2	-18	-14	-12	-10	-44	-40	-35	-45	-40	-33	1500

Notes: 1. Add suffix "T" to part number for Tape & Reel package (ie: **R1001NLT**).

## Mechanical

R1001NL

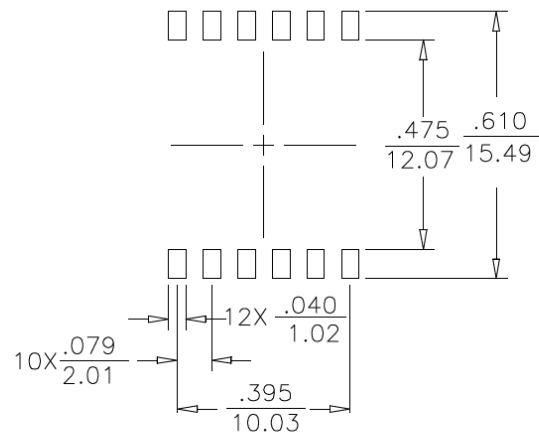
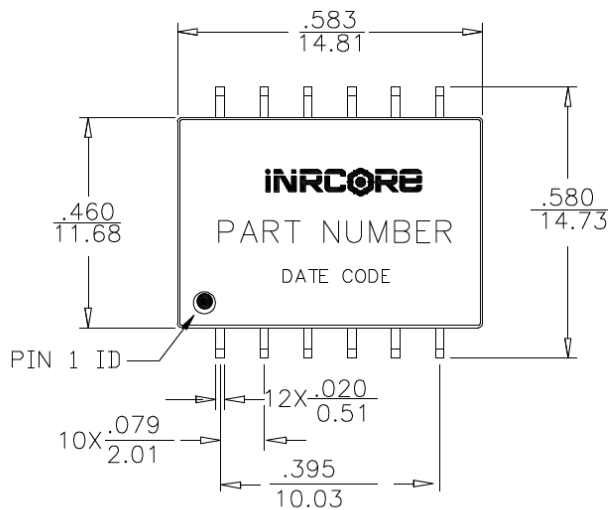

SUGGESTED LAND PATTERN

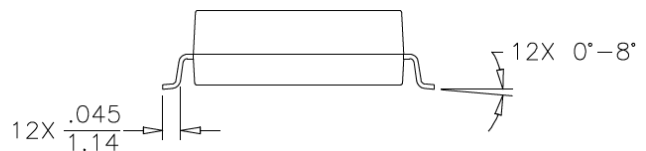
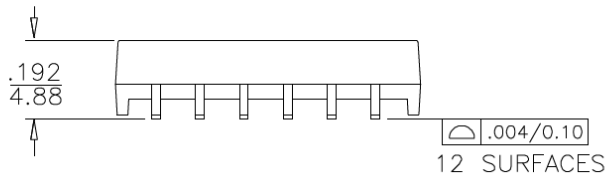

DIMENSIONS:  $\frac{\text{Inches}}{\text{mm}}$

UNLESS OTHERWISE SPECIFIED, ALL TOLERANCES ARE  $\pm \frac{.010}{0.25}$

Weight: 1.7 gram  
Tape and Reel: 340/reel  
Tube: 30/tube



# 10/100BASE-T TRANSFORMER MODULES

Industrial grade



## Electrical Schematic

R1001NL

