

**RIGHT ANGLE PLUG CRIMP TYPE**

**CABLE 2.6/50 S**

**R113.182.020**

Series : MCX

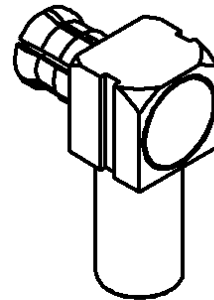
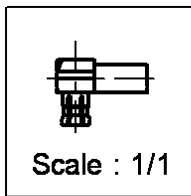
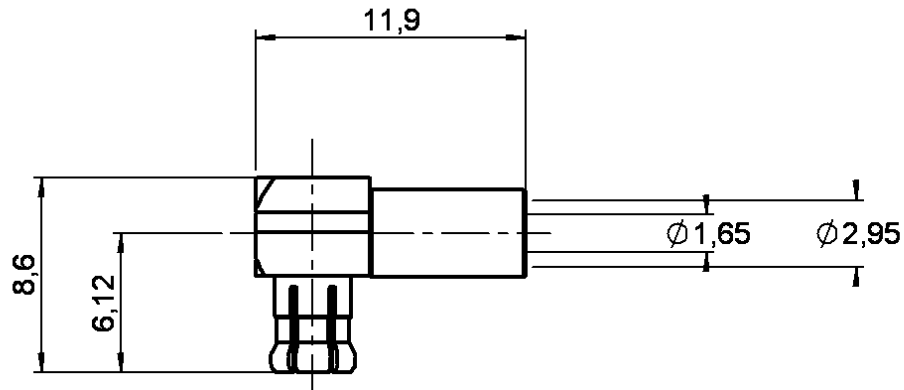

All dimensions are in mm.



COMPONENTS	MATERIALS	PLATING (µm)
BODY	BRASS	BBR 2
CENTER CONTACT	BRASS	.GOLD 1.3 OVER NICKEL 2
OUTER CONTACT	BERYLLIUM COPPER	BBR 2
INSULATOR	PTFE	
GASKET	-	
OTHERS PARTS	-	BBR 2
-	-	-
-	-	-

Issue : 0107 H

In the effort to improve our products, we reserve the right to make changes judged to be necessary.



**RIGHT ANGLE PLUG CRIMP TYPE**

**R113.182.020**

**CABLE 2.6/50 S**

Series : MCX

**PACKAGING**

Standard	Unit	Other
<b>100</b>	<b>'W' option</b>	<b>Contact us</b>

**SPECIFICATION**

**ELECTRICAL CHARACTERISTICS**

Impedance		<b>50</b> Ω
Frequency		<b>0-6</b> GHz
VSWR	<b>1.10 +</b>	<b>0,0750</b> x F(GHz) Maxi
Insertion loss		<b>0.5</b> √F(GHz) dB Maxi
RF leakage	- (	<b>NA</b> - F(GHz)) dB Maxi
Voltage rating		<b>170</b> Veff Maxi
Dielectric withstanding voltage		<b>500</b> Veff mini
Insulation resistance		<b>1000</b> MΩ mini

**CABLE ASSEMBLY**

Stripping	a	b	c	d	e	f
mm	2,00	5,00	8,00	0,00	6,00	0,00

Assembly instruction : **Crimp 08**

Recommended cable(s)

KX 22A

RG 188

RG 316

Characteristics indicated on this data sheet are those that can be achieved with the highest performance cable. Intrinsic limitations of the cable may diminish the performance of the assembly

Cable retention

- pull off **53** N mini  
- torque **1.3** N.cm

**MECHANICAL CHARACTERISTICS**

Center contact retention		
Axial force – Mating end	<b>10</b>	N mini
Axial force – Opposite end	<b>10</b>	N mini
Torque	<b>NA</b>	N.cm mini

**TOOLING**

Part Number	Description	Hexagon
.	.	.
R282.235.003	CRIMPING DIES	3.25
R282.271.000	CRIMPING TOOL	3.25
R282.293.000	CRIMPING TOOL M22520/5-01	-
R282.868.000	EXTRACTION ASSEMBLY TOOL	-

Recommended torque		
Mating	<b>NA</b>	N.cm
Panel nut	<b>NA</b>	N.cm
Clamp nut	<b>NA</b>	N.cm
A/F clamp nut	<b>0,0000</b>	mm

Mating life	<b>500</b>	Cycles mini
Weight	<b>1,1310</b>	g

**OTHER CHARACTERISTICS**

**ENVIRONMENTAL**

Operating temperature	<b>-55/+155</b>	° C
Hermetic seal	<b>NA</b>	Atm.cm3/s
Panel leakage	<b>NA</b>	

Issue : 0107 H

In the effort to improve our products, we reserve the right to make changes judged to be necessary.

