

**RIGHT ANGLE PLUG CRIMP TYPE**  
**NON MAGNETIC CABLE 2.6/50 S**

**R113.182.097**

Series : MCX

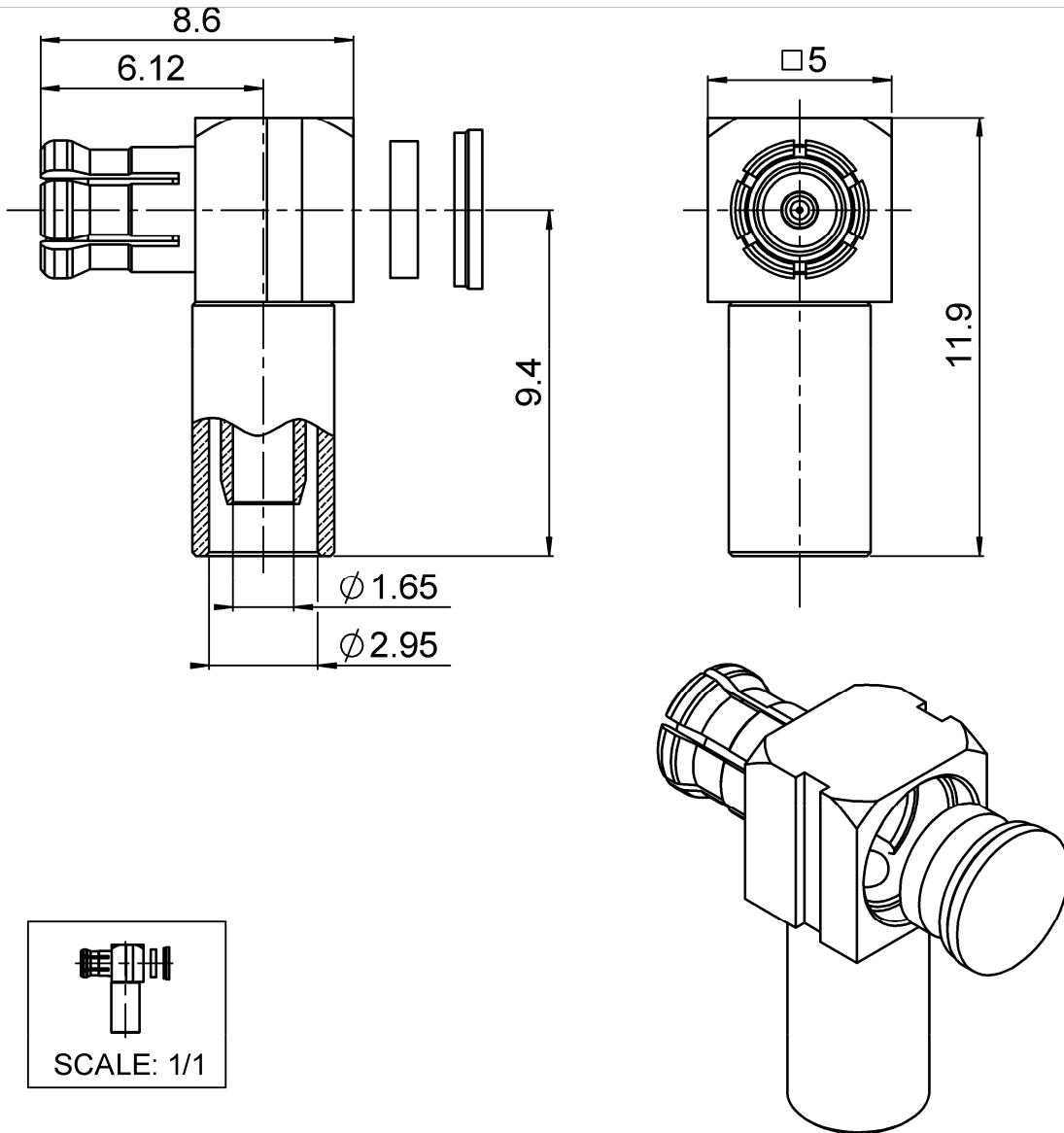

All dimensions are in mm.

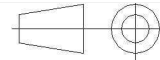

COMPONENTS	MATERIALS	PLATING ( $\mu\text{m}$ )
BODY	NON MAGNETIC BRONZE	BBR
CENTER CONTACT	NON MAGNETIC BRONZE	GOLD OVER COPPER
OUTER CONTACT	BERYLLIUM COPPER	BBR
INSULATOR	PTFE	
GASKET		
OTHERS PARTS	NON MAGNETIC BRONZE	BBR
-	-	-
-	-	-

Issue : 1145 A

In the effort to improve our products, we reserve the right to make changes judged to be necessary.



**RIGHT ANGLE PLUG CRIMP TYPE**

**R113.182.097**

**NON MAGNETIC CABLE 2.6/50 S**

Series : **MCX**

**PACKAGING**

Standard	Unit	Other
<b>100</b>	<b>'W' option</b>	<b>Contact us</b>

**SPECIFICATION**

**ELECTRICAL CHARACTERISTICS**

Impedance		<b>50</b> Ω
Frequency		<b>0-6</b> GHz
VSWR	<b>1.1 +</b>	<b>0,0750</b> x F(GHz) Maxi
Insertion loss		<b>0.5</b> √F(GHz) dB Maxi
RF leakage	- (	<b>NA</b> - F(GHz)) dB Maxi
Voltage rating		<b>170</b> Veff Maxi
Dielectric withstanding voltage		<b>500</b> Veff mini
Insulation resistance		<b>1000</b> MΩ mini

**CABLE ASSEMBLY**

Stripping	a	b	c	d	e	f
mm	2,00	5,00	8,00	0,00	6,00	0,00

Assembly instruction : **Crimp 08**

Recommended cable(s)  
RG 316

Characteristics indicated on this data sheet are those that can be achieved with the highest performance cable. Intrinsic limitations of the cable may diminish the performance of the assembly

Cable retention

- pull off **53** N mini  
- torque **NA** N.cm

**MECHANICAL CHARACTERISTICS**

Center contact retention		
Axial force – Mating end	<b>10</b>	N mini
Axial force – Opposite end	<b>10</b>	N mini
Torque	<b>NA</b>	N.cm mini

Recommended torque		
Mating	<b>NA</b>	N.cm
Panel nut	<b>NA</b>	N.cm
Clamp nut	<b>NA</b>	N.cm
A/F clamp nut	<b>0,0000</b>	mm

Mating life	<b>500</b>	Cycles mini
Weight	<b>1,1600</b>	g

**TOOLING**

Part Number	Description	Hexagon
.	.	.
R282.235.003	CRIMPING DIES M22520/5-03	3.25
R282.271.000	CRIMPING TOOL	3.25
R282.293.000	CRIMPING TOOL M22520/5-01	
R282.868.000	EXTRACTION ASSEMBLY TOOL	

**OTHER CHARACTERISTICS**

Distortion of the magnetic field :  
<= 0.5 ppm@ 10 mm @ Bo = 1.5 Tesla

**ENVIRONMENTAL**

Operating temperature	<b>-55/+125</b>	° C
Hermetic seal	<b>NA</b>	Atm.cm3/s
Panel leakage	<b>NA</b>	

Issue : **1145 A**

In the effort to improve our products, we reserve the right to make changes judged to be necessary.

