

STRAIGHT JACK CRIMP TYPE
NON MAGNETIC CABLE 2.6/50 S

R113.240.097

Series : MCX

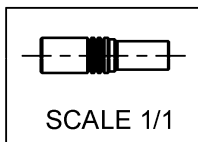
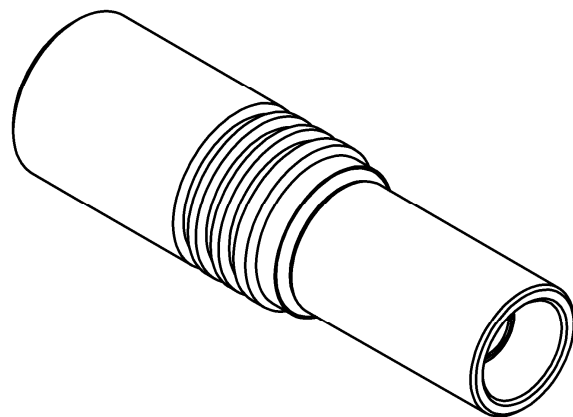
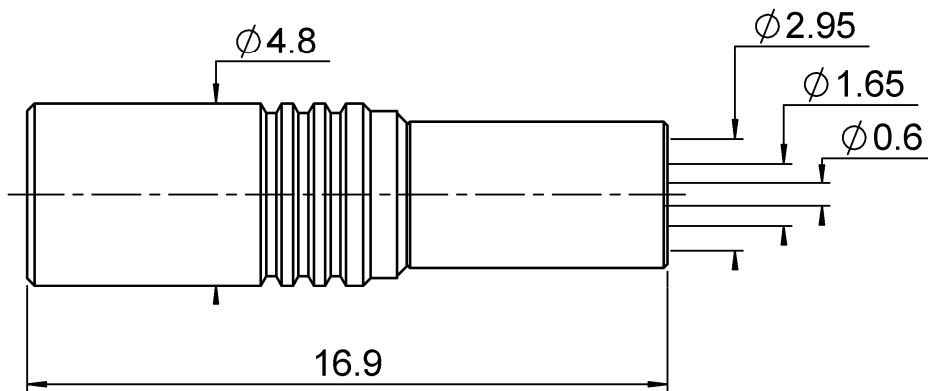

All dimensions are in mm.

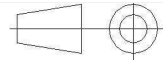

COMPONENTS	MATERIALS	PLATING (μm)
BODY	NON MAGNETIC BRONZE	BBR
CENTER CONTACT	BERYLLIUM COPPER	GOLD OVER COPPER
OUTER CONTACT		
INSULATOR	PTFE	
GASKET		
OTHERS PARTS	NON MAGNETIC BRONZE	BBR
-	-	-
-	-	-

Issue : 1145 A

In the effort to improve our products, we reserve the right to make changes judged to be necessary.



STRAIGHT JACK CRIMP TYPE
NON MAGNETIC CABLE 2.6/50 S

R113.240.097

Series : MCX

PACKAGING

Standard	Unit	Other
100	'W' option	Contact us

SPECIFICATION

ELECTRICAL CHARACTERISTICS

Impedance		50 Ω
Frequency		0-6 GHz
VSWR	1.1 +	0,0400 x F(GHz) Maxi
Insertion loss		0.25 √F(GHz) dB Maxi
RF leakage	- (NA - F(GHz)) dB Maxi
Voltage rating		170 Veff Maxi
Dielectric withstanding voltage		500 Veff mini
Insulation resistance		1000 MΩ mini

CABLE ASSEMBLY

Stripping	a	b	c	d	e	f
mm	2,50	6,00	10,0	0,00	7,50	0,00

Assembly instruction : **Crimp 02**

Recommended cable(s)
RG 316

Characteristics indicated on this data sheet are those that can be achieved with the highest performance cable. Intrinsic limitations of the cable may diminish the performance of the assembly

Cable retention

- pull off **53** N mini
- torque **NA** N.cm

MECHANICAL CHARACTERISTICS

Center contact retention		
Axial force – Mating end	NA	N mini
Axial force – Opposite end	NA	N mini
Torque	NA	N.cm mini

Recommended torque		
Mating	NA	N.cm
Panel nut	NA	N.cm
Clamp nut	NA	N.cm
A/F clamp nut	0,0000	mm

Mating life	500	Cycles mini
Weight	1,3140	g

TOOLING

Part Number	Description	Hexagon
.	.	.
R282.235.003	CRIMPING DIES M22520/5-03	3.25
R282.271.000	CRIMPING TOOL	3.25 - SQUARE 0.72
R282.293.000	CRIMPING TOOL M22520/5-01	

OTHER CHARACTERISTICS

Distortion of the magnetic field :
<= 0.5 ppm@ 10 mm @ Bo = 1.5 Tesla

ENVIRONMENTAL

Operating temperature	-55/+125	° C
Hermetic seal	NA	Atm.cm3/s
Panel leakage	NA	

Issue : 1145 A

In the effort to improve our products, we reserve the right to make changes judged to be necessary.

