

STRAIGHT CABLE PLUG-SOLDER TYPE
CABLE .085

PEN DEP90.R121.000

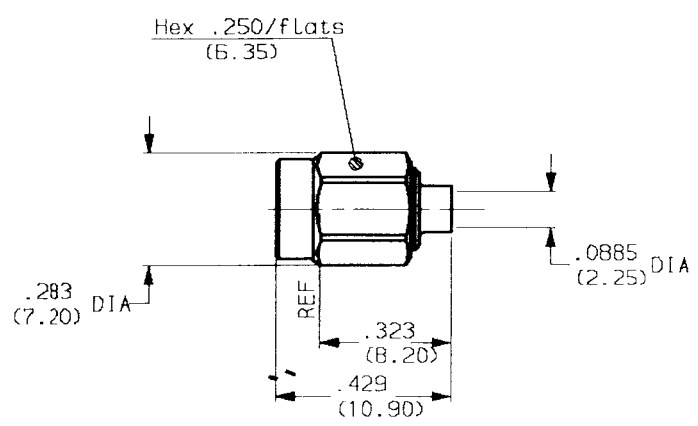

weight 0.053 oz (1.5 g) cables:RG 405

CHARACTERISTICS

NOMINAL IMPEDANCE	50 Ω
FREQUENCY RANGE	0-18 GHz
TEMPERATURE RATING	-65/+115 °C
VSWR	AD Max
RF INSERTION LOSS	AD \sqrt{f} dB Maxi
VOLTAGE RATING	250 Vrms Maxi
DIELECTRIC WITHSTANDING VOLTAGE	750 Vrms mini
INSULATION RESISTANCE	5000 Ma mini
HERMETIC SEAL	NA cc/s Atm.cm ³ /s
LEAKAGE (pressurized only)	NA psi MPa
-	-
-	-

STANDARDISATION	
CABLE RETENTION	45 Lb mini 200 N
CENTER CONTACT RETENTION	
Axial force - mating end	NA Lb mini N
Axial force - opposite end	NA Lb mini N
Torque (Min)	NA Inch.oz cm.N
RECOMMENDED TORQUES	
Mating	7.088 Inch.Lb 80 cm.N
Panel nut	NA Inch.Lb cm.N
Clamp nut	NA Inch.Lb cm.N

CONSTRUCTION

CONNECTOR PARTS	MATERIALS	FINISH
BODY	BERYLLIUM COPPER	Nickel
OUTER CONTACT	-	-
CENTER CONTACT	BERYLLIUM COPPER	Gold over nickel
INSULATORS	PTFE	-
COUPLING NUT	STAINLESS STEEL	Passivated
GASKET	SILICON	-
-	-	-
-	-	-
-	-	-

ISSUE	REVISION No	DESCRIPTION	BY	DATE
.
.
.
.

Initiated on 06-SEP-90
Superseded on - - - - -

The information given here is subject to change without notice. Design changes may be in order to improve the product.



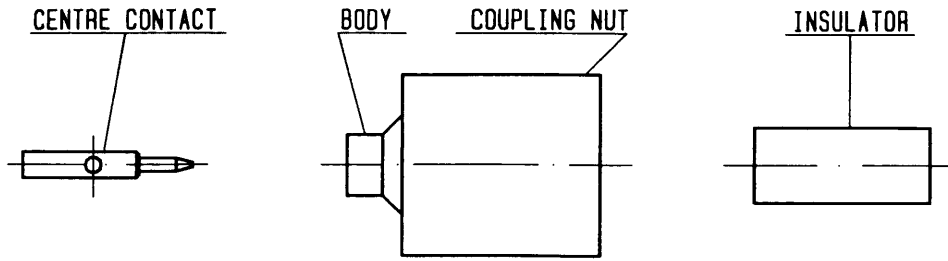

① Take the tool kit : R 282 118 000 .
Insert the cable into end B of the cable trimming tool (N° 21).
Saw through cable outer and into dielectric whilst turning the cable.
Cut through the dielectric.
Trim the end of the cable.

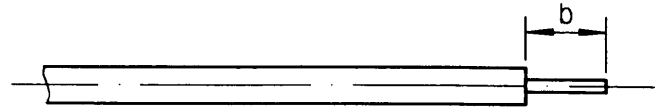

Stripping	a	b	c	d	e
inch	0	0.079 0	0	0	0
mm	-	2	-	-	-

② Place the cable into the assembly jig. (N° 10).
Slide contact onto the cable.
Insert solder gauge (N° 60) between contact and cable .
Tighten and solder the contact .

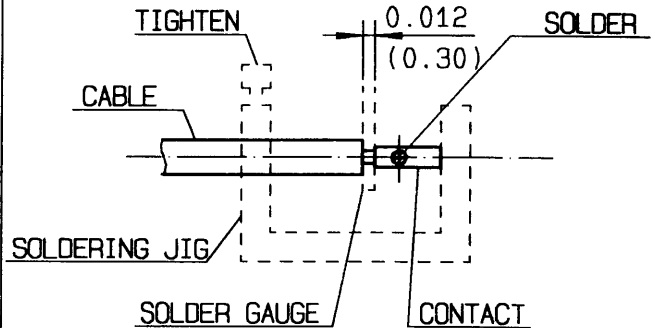

③ After cooling remove cable assembly from the jig .
Screw positioner (N° 75) into the connector .
Slide cable into the connector until it bottoms against positioner.
Tighten .
Put 3 rings of solder around the cable and solder .

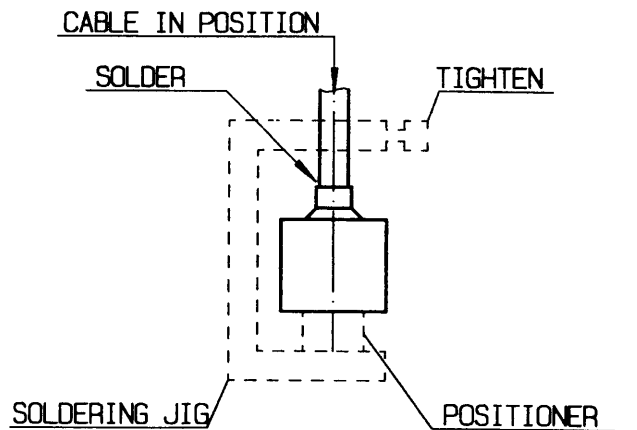

④ After cooling remove cable assembly from the jig .
Screw female dielectric insert tool onto connector and insert insulator with the dielectric plunger .
Dielectric insert tool (N° 30) and dielectric plunger (N° 32).

