

DEMONSTRATION BOARD

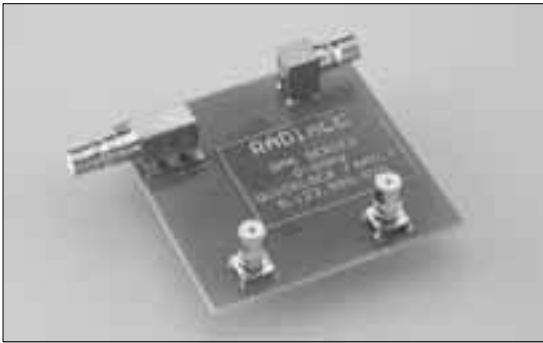

part number
R123 990 020W

QMA PIGTAIL

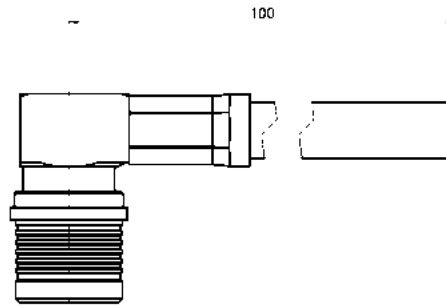

part number	description	length
R284 V01 01 003	R123 176 000+C291 320 007	10 cm

IN SERIES ADAPTERS

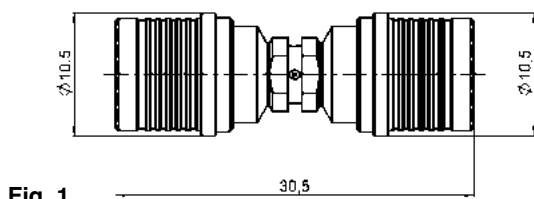

Fig. 1

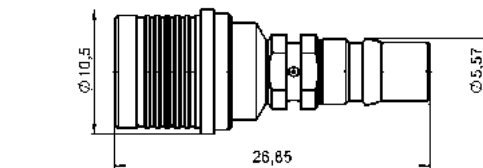

Fig. 2

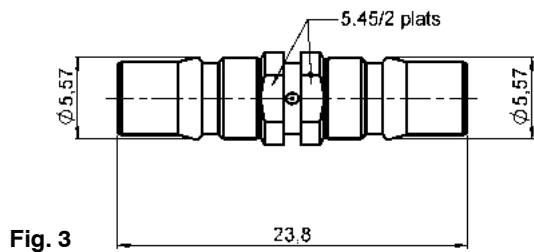

Fig. 3

part number	fig.	captive center contact	finish	note
R123 703 000	1	yes	BBR	QMA MALE - QMA MALE
R123 704 000	2	yes	BBR	QMA FEMALE - QMA MALE
R123 705 000	3	yes	BBR	QMA FEMALE - QMA FEMALE

Packaging: 100 pcs. For unit packaging, add "W" after the P/N.