

**STRAIGHT 2 HOLES FLANGE JACK SOLDER TYPE
CABLE .085**

**R124.252.003
SERIES SMA-COM**

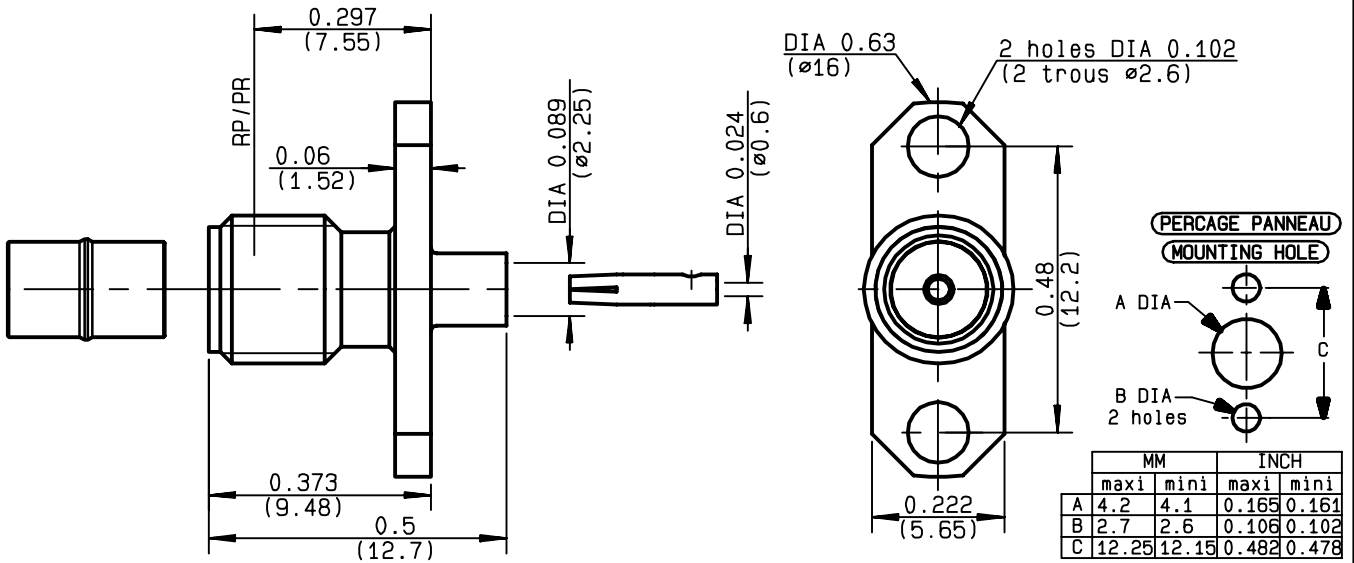

NOMINAL IMPEDANCE	50 Ω	CABLES : KS 1
FREQUENCY RANGE	0-18 GHz	RG 405
TEMPERATURE RATING	-65/+105 °C	
V.S.W.R	1.07 + .01 x F(GHz)Maxi	
RF INSERTION LOSS	0.05 √F(GHz) dB Maxi	
VOLTAGE RATING	335 Veff Maxi	
DIELECTRIC WITHSTANDING VOLTAGE	750 Veff Mini	
INSULATION RESISTANCE	5000 MΩMini	OTHERS CHARACTERISTICS
HERMETIC SEAL	NA Atm.cm ³ /s	CABLE RETENTION
LEAKAGE (pressurized only)	NA	130 N Mini
MECHANICAL DURABILITY	100 Cycles	CENTER CONTACT RETENTION
WEIGHT	1.9 gr	Axial force - mating end
SPECIFICATION		NA N Mini
		Axial force - opposite end
		NA N Mini
		Torque
		NA cm.N Mini
		RECOMMENDED TORQUES
		Mating
		NA cm.N
		Panel nut
		NA cm.N
		Clamp nut
		NA cm.N

CONNECTOR PARTS	MATERIALS	FINISH
BODY	BRASS	GOLD 0.2 OVER NICKEL 2
OUTER CONTACT		
CENTER CONTACT	BERYLLIUM COPPER	GOLD 1.3 OVER COPPER 2.5
INSULATOR	PTFE	-
GASKET		-
OTHERS PIECES		

(all values are given in micrometers)

ISSUE	CREATION DATE	FILE PART-NUMBER	
9847A00	21/11/1997	96-1200-075	

The information given here is subject to change without notice. Design changes may be in order to improve the product.

TRIQUES



R124.252.003

ISSUE **9847A00** SERIES **SMA-COM**

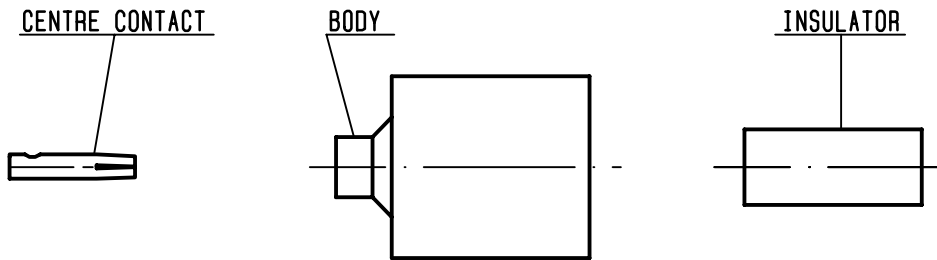

We recommend a cable thermal preconditioning before assembling

①

Take the tool kit : R282.120.000
 Strip the dielectric of the cable .
 Stripping tool cable : R282.051.000
 Trimmer : R282.063.000
 Clean the cable .
 -

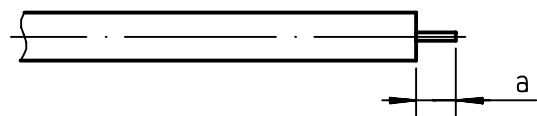

Stripping	a	b	c	d	e
inch	0.1250	0	0	0	0
mm	3.17				

②

Screw the positioner R282.744.220 onto the soldering jig R282.740.000
 Slide contact into positioner .
 Insert solder gauge R282.862.060 between contact and cable .
 Tighten and solder the contact .

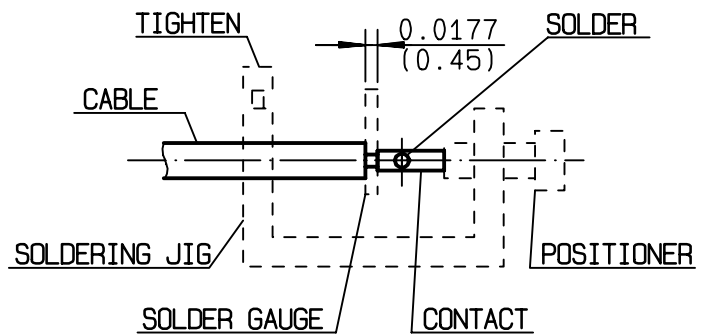

③

After cooling remove cable assembly from the jig .
 Screw positioner R282.744.010 into the connector .
 Slide cable into the connector until it bottoms againsts positioner R282.744.010 .
 Tighten .
 Put 3 rings of solder around the cable and solder .

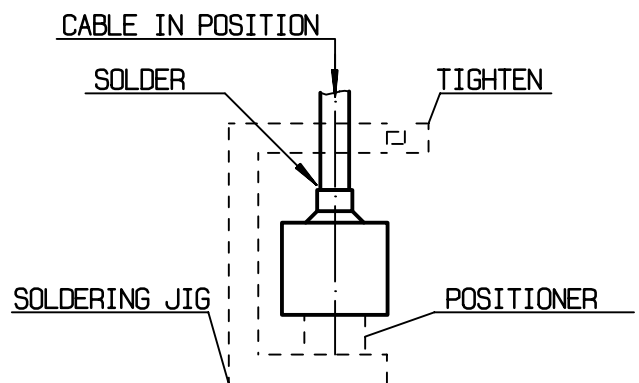

④

After cooling remove cable assembly from the jig .
 Screw positioner cut R282.914.010
 Cut the dielectric flush to clamp braid sleeve with tool R282.915.010.
 Screw female dielectric insert tool onto connector and insert insulator with the dielectric plunger R282.730.043

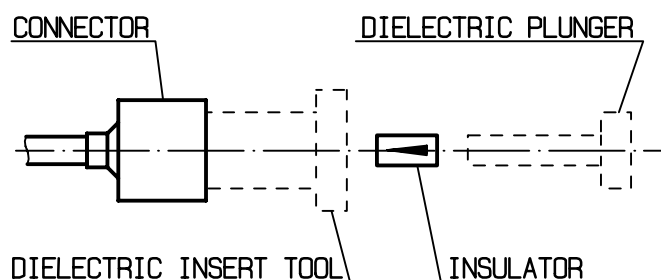

TRIQUES