

**SMA FEMALE - SMA FEMALE BULKHEAD
STRAIGHT ADAPTER**

R124.720.123

Series : SMA-COM

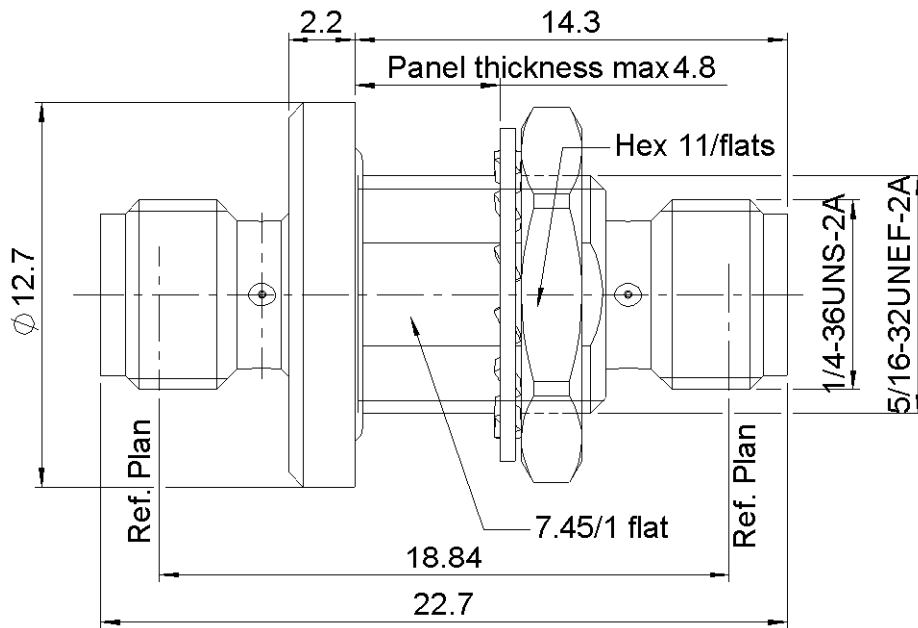

PANEL CUT OUT

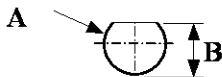

mm		
	Maxi	mini
A	8.00	7.90
B	7.65	7.55

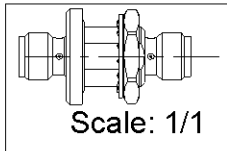
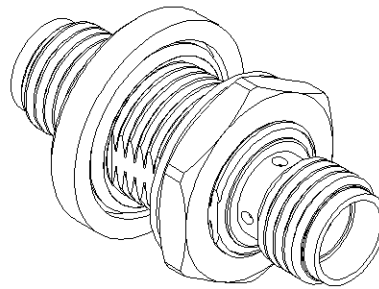

All dimensions are in mm.

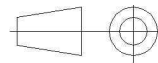

COMPONENTS	MATERIALS	PLATING (µm)
BODY	BRASS	GOLD 0.2 OVER NICKEL 2
CENTER CONTACT	BERYLLIUM COPPER	GOLD 1.3 OVER COPPER 2.5
OUTER CONTACT		
INSULATOR	PTFE	
GASKET	SILICONE RUBBER	
OTHERS PARTS	BRASS	GOLD 0.2 OVER NICKEL 2
-	-	-
-	-	-

Issue : 0850 A

In the effort to improve our products, we reserve the right to make changes judged to be necessary.



SMA FEMALE - SMA FEMALE BULKHEAD

R124.720.123

STRAIGHT ADAPTER

Series : SMA-COM

PACKAGING

SPECIFICATION

Standard	Unit	Other
100	'W' option	Contact us

ELECTRICAL CHARACTERISTICS

ENVIRONMENTAL

Impedance	50	Ω
Frequency	0-18	GHz
VSWR	1.05* + 0,0150	x F(GHz) Maxi
Insertion loss	0.07*	\sqrt{F} (GHz) dB Maxi
RF leakage	- (100)	- F(GHz)) dB Maxi
Voltage rating	500	Veff Maxi
Dielectric withstanding voltage	1000	Veff mini
Insulation resistance	5000	M Ω mini

Operating temperature	-65/+165	$^{\circ}$ C
Hermetic seal	NA	Atm.cm3/s
Panel leakage	NA	

OTHER CHARACTERISTICS

Assembly instruction **NA**

Others :
* up to 6GHz

MECHANICAL CHARACTERISTICS

Center contact retention		
Axial force – Mating end	27	N mini
Axial force – Opposite end	27	N mini
Torque	2.8	N.cm mini
Recommended torque		
Mating	NA	N.cm
Panel nut	200	N.cm
Mating life	100	Cycles mini
Weight	6,8300	g

Issue : 0850 A

In the effort to improve our products, we reserve the right to make changes judged to be necessary.

