

**STRAIGHT PLUG CLAMP TYPE
CABLE 2.2/50 D**

R125.002.200
SERIES SMA

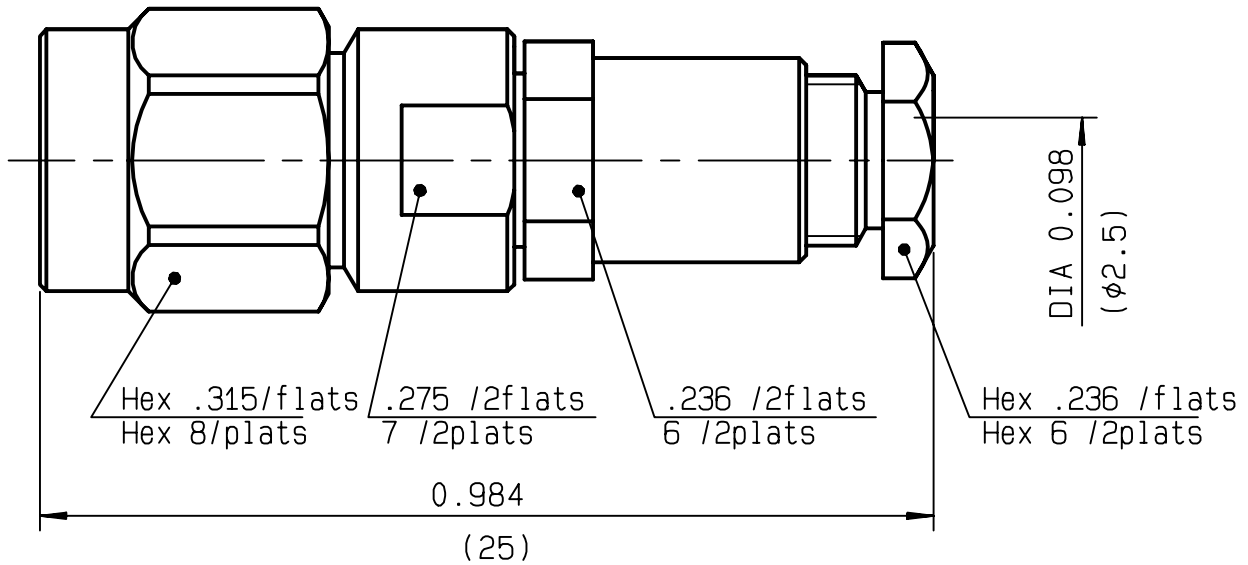

NOMINAL IMPEDANCE	50 Ω
FREQUENCY RANGE	0-12.4 GHz
TEMPERATURE RATING	-65/+165 °C
V.S.W.R	1.1 + .004 x F(GHz) Maxi
RF INSERTION LOSS	0.06 √F(GHz) dB Maxi
VOLTAGE RATING	335 Veff Maxi
DIELECTRIC WITHSTANDING VOLTAGE	750 Veff Mini
INSULATION RESISTANCE	5000 MΩMini
HERMETIC SEAL	NA Atm.cm ³ /s
LEAKAGE (pressurized only)	NA
MECHANICAL DURABILITY	500 Cycles
WEIGHT	7 gr
SPECIFICATION	

CABLES : TS 2619	
OTHERS CHARACTERISTICS	
CABLE RETENTION	120 N Mini
CENTER CONTACT RETENTION	
Axial force - mating end	27 N Mini
Axial force - opposite end	27 N Mini
Torque	NA cm.N Mini
RECOMMENDED TORQUES	
Mating	100 cm.N
Panel nut	NA cm.N
Clamp nut	40 cm.N

CONNECTOR PARTS	MATERIALS	FINISH	(all values are given in micrometers)
BODY	STAINLESS STEEL	PASSIVATED	.
OUTER CONTACT			
CENTER CONTACT	BRASS	GOLD 1.3 OVER NICKEL 2	
INSULATOR	PTFE	-	
GASKET	SILICONE RUBBER	-	
OTHERS PIECES	STAINLESS STEEL	PASSIVATED	.

ISSUE	CREATION DATE	FILE PART-NUMBER
9840B00	08/11/1993	92-0019-102



Y. PERRIN

The information given here is subject to change without notice.
Design changes may be in order to improve the product .

Connect to the future



R125.002.200

ISSUE **9840B00** SERIES **SMA**

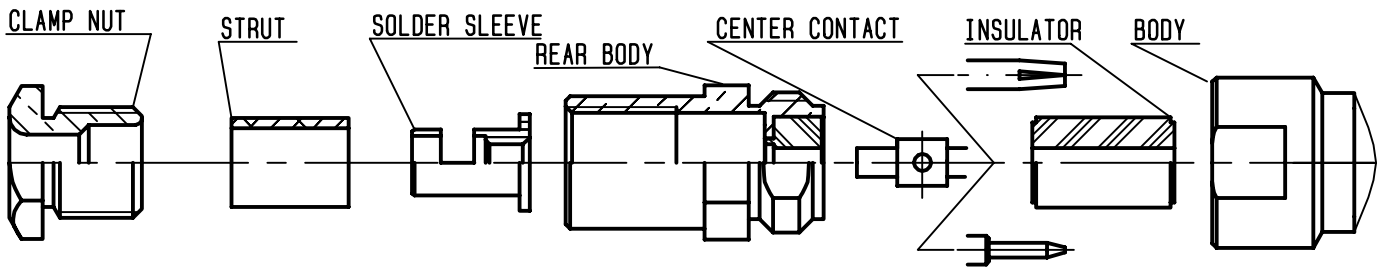

①

Slide the clamp nut ,
the strut onto the cable

Strip the cable .
Dip tinned centre conductor of cable .

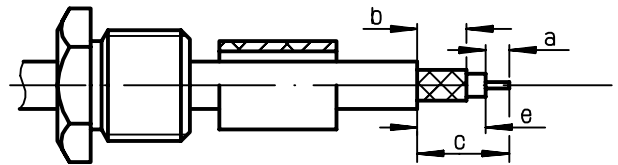

Stripping	a	b	c	d	e
inch	0.098	0.118	0.394	0	0.295
mm	2.5	3	10		7.5

②

Solder the solder sleeve onto the braid .
Slide the rear body until it bottoms
against the solder sleeve .
Slide the center contact until it bottoms
against the rear body .
Solder the center contact .
Mount the insulator on the
center contact .

-
-
-
-
-
-
-
-

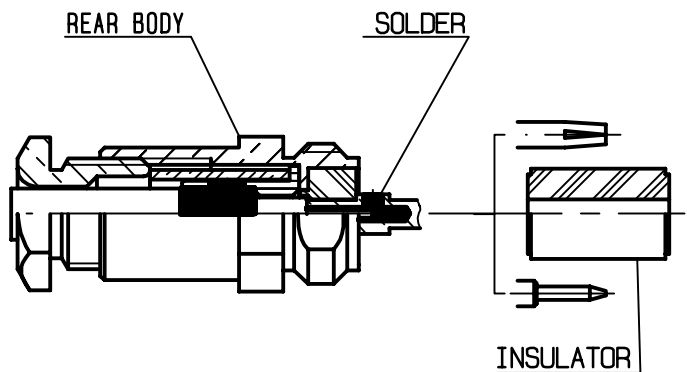
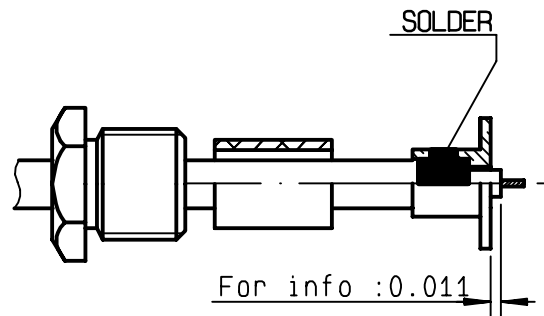

③

Screw sub-assembly into the connector
body .
(recommended coupling torque 3.53 in.lb)
Ref. wrench .236/flats : R282 318 000

-

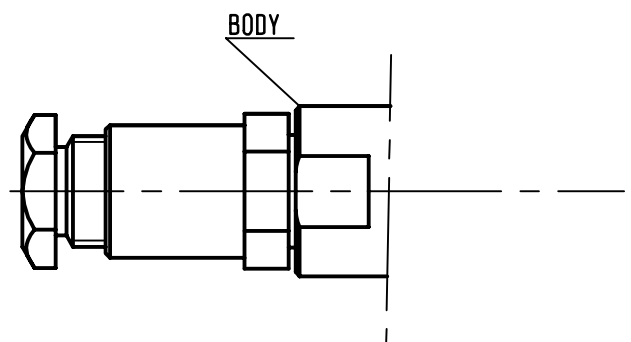

Y.PERRIN