

**STRAIGHT PLUG SOLDER TYPE**

**R125.055.702**

**CABLE .141**

Series : SMA-27

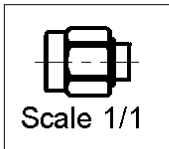
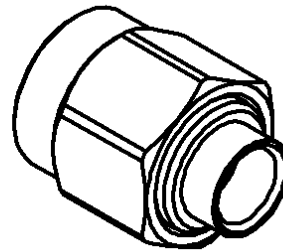
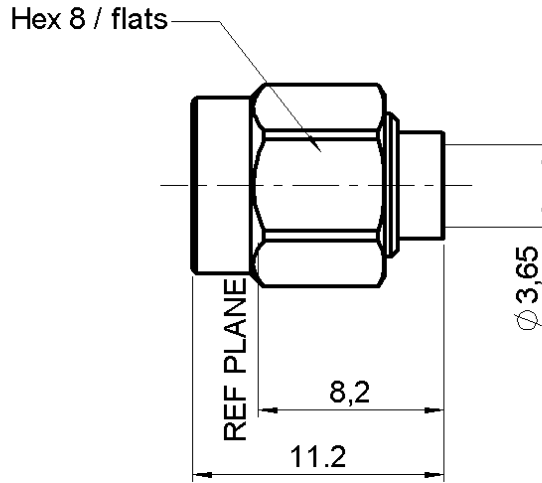

All dimensions are in mm.



COMPONENTS	MATERIALS	PLATINGS (µm)
BODY	STAINLESS STEEL	GOLD 0.5 OVER NICKEL 2
CENTER CONTACT	BRASS	GOLD 1.3 OVER NICKEL 2
OUTER CONTACT	-	-
INSULATOR	PTFE	-
GASKET	SILICONE RUBBER	-
OTHERS PARTS	STAINLESS STEEL	GOLD 0.5 OVER NICKEL 2
-	-	-
-	-	-

Issue : 0203 C

In the effort to improve our products, we reserve the right to make changes judged to be necessary.



**STRAIGHT PLUG SOLDER TYPE**

**R125.055.702**

**CABLE .141**

Series : SMA-27

**PACKAGING**

Standard	Unit	Other
<b>100</b>	<b>'W' option</b>	<b>Contact us</b>

**SPECIFICATION**

**ELECTRICAL CHARACTERISTICS**

Impedance		<b>50</b>	$\Omega$
Frequency		<b>0-27</b>	GHz
VSWR	<b>1.05</b> +	<b>0.008</b>	x F(GHz) Maxi
Insertion loss		<b>0.03</b>	$\sqrt{F}$ (GHz) dB Maxi
RF leakage	- (	<b>90</b>	- F(GHz)) dB Maxi
Voltage rating		<b>500</b>	Veff Maxi
Dielectric withstanding voltage		<b>1000</b>	Veff mini
Insulation resistance		<b>5000</b>	M $\Omega$ mini

**CABLE ASSEMBLY**

Stripping	a	b	c	d	e	f
mm	3.17	0.00	0.00	0.00	0.00	0.00

Assembly instruction :

Recommended cable(s)  
RG 402  
KS 2

Cable retention

- pull off **270** N mini  
- torque **NA** N.cm

**MECHANICAL CHARACTERISTICS**

Center contact retention			
Axial force – Mating end		<b>NA</b>	N mini
Axial force – Opposite end		<b>NA</b>	N mini
Torque		<b>NA</b>	N.cm mini

Recommended torque			
Mating		<b>100</b>	N.cm
Panel nut		<b>NA</b>	N.cm
Clamp nut		<b>NA</b>	N.cm
A/F clamp nut		<b>0.000</b>	mm

Mating life		<b>500</b>	Cycles mini
Weight		<b>2.226</b>	g

**TOOLING**

Part Number	Description	Hexagon
.	.	.
R282.053.000	STRIPPING TOOL	
R282.120.000	SMA BOX SOLDER TYPE	
R282.067.000	POINTER GAUGE	

**OTHERS CHARACTERISTICS**

-

**ENVIRONMENTAL**

Operating temperature		<b>-65/+105</b>	$^{\circ}$ C
Hermetic seal		<b>NA</b>	Atm.cm3/s
Panel leakage		<b>NA</b>	

Issue : 0203 C

In the effort to improve our products, we reserve the right to make changes judged to be necessary.

