

STRAIGHT JACK CRIMP TYPE

CABLE 5/50 S

R125.237.000

Series : SMA

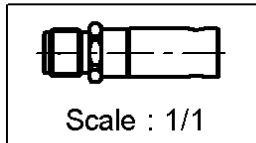
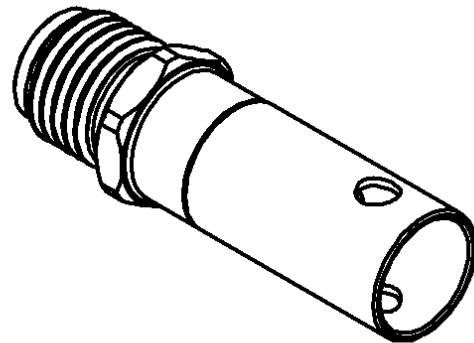
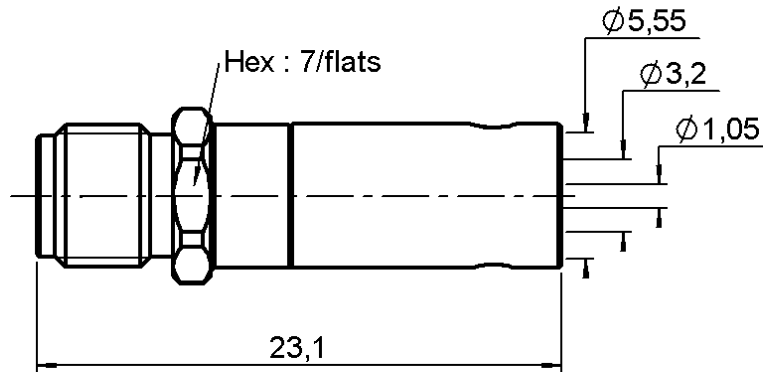

All dimensions are in mm.



COMPONENTS	MATERIALS	PLATINGS (µm)
BODY	STAINLESS STEEL	GOLD 0.5 OVER NICKEL 2
CENTER CONTACT	BERYLLIUM COPPER	GOLD 1.3 OVER NICKEL 2
OUTER CONTACT	-	-
INSULATOR	PTFE	-
GASKET	-	-
OTHERS PARTS	BRASS	GOLD 0.2 OVER NICKEL 2
-	-	-
-	-	-

Issue : 0319 J

In the effort to improve our products, we reserve the right to make changes judged to be necessary.



STRAIGHT JACK CRIMP TYPE

R125.237.000

CABLE 5/50 S

Series : SMA

PACKAGING

Standard	Unit	Other
100	'W' option	Contact us

SPECIFICATION

ELECTRICAL CHARACTERISTICS

Impedance		50 Ω
Frequency		0-12.4 GHz
VSWR	1.15 +	0.010 x F(GHz) Maxi
Insertion loss		0.06 √F(GHz) dB Maxi
RF leakage	- (60 - F(GHz)) dB Maxi
Voltage rating		335 Veff Maxi
Dielectric withstanding voltage		1000 Veff mini
Insulation resistance		5000 MΩ mini

CABLE ASSEMBLY

Stripping	a	b	c	d	e	f
mm	3.50	7.00	13.5	0.00	10.0	0.00

Assembly instruction : **Crimp 01**

Recommended cable(s)
 KX 15
 RG 58
 RG 141

Characteristics indicated on this data sheet are those that can be achieved with the highest performance cable. Intrinsic limitations of the cable may diminish the performance of the assembly

Cable retention

- pull off **180** N mini
 - torque **NA** N.cm

MECHANICAL CHARACTERISTICS

Center contact retention		
Axial force – Mating end	NA	N mini
Axial force – Opposite end	NA	N mini
Torque	NA	N.cm mini

TOOLING

Part Number	Description	Hexagon
.	.	.
R282.223.000	CRIMPING TOOL	5.40
R282.293.000	CRIMPING TOOL	-
R282.235.011	CRIMPING DIES	5.40

Recommended torque		
Mating	NA	N.cm
Panel nut	NA	N.cm
Clamp nut	NA	N.cm
A/F clamp nut	0.000	mm

Mating life	500	Cycles mini
Weight	3.100	g

OTHERS CHARACTERISTICS

-

ENVIRONMENTAL

Operating temperature	-65/+165	° C
Hermetic seal	NA	Atm.cm3/s
Panel leakage	NA	

Issue : 0319 J

In the effort to improve our products, we reserve the right to make changes judged to be necessary.

