

**STRAIGHT FLOATING SNAP-IN MOUNT JACK**  
**CRIMP TYPE CABLE 5/50 DTR**

**R128.238.701**

Series : BMA

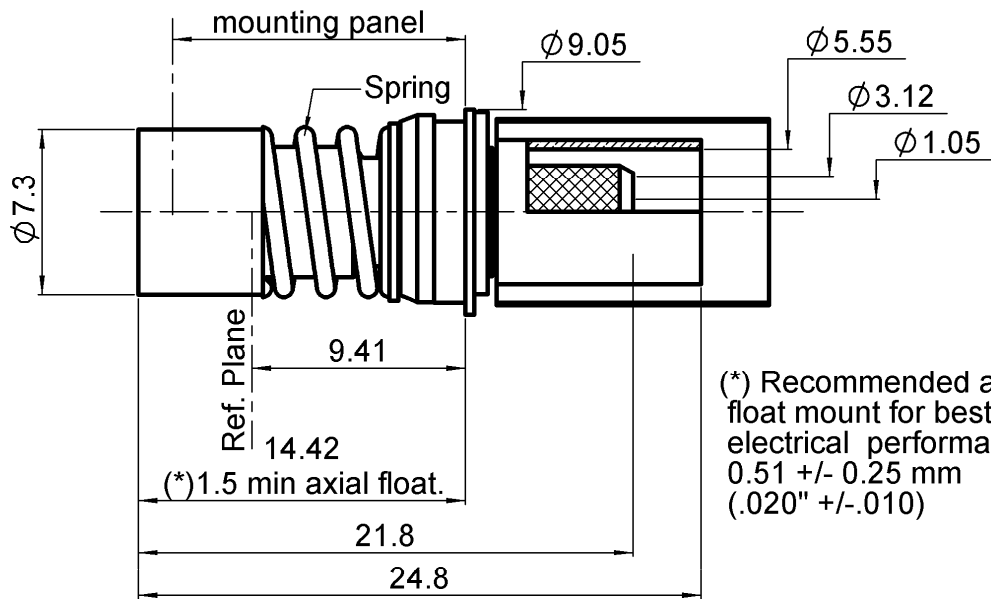

(\*) Recommended axial float mount for best electrical performance: 0.51 +/- 0.25 mm (.020" +/- .010)

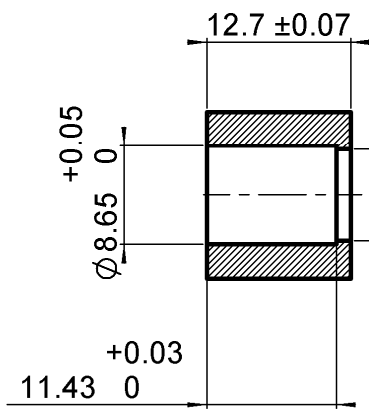

PANEL DRILLING

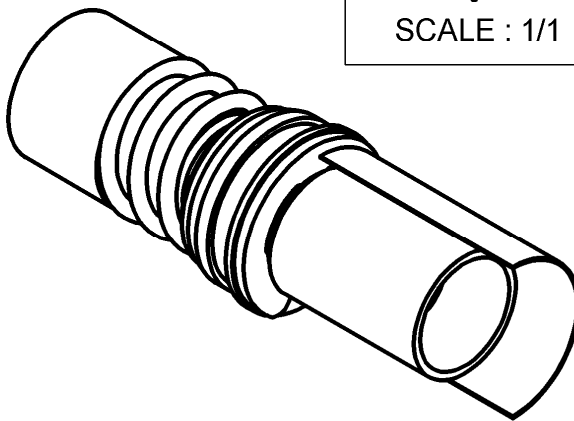
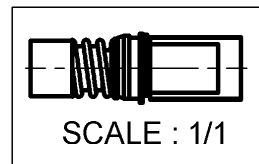

All dimensions are in mm.

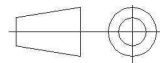

COMPONENTS	MATERIALS	PLATING (µm)
BODY	STAINLESS STEEL	PASSIVATION
CENTER CONTACT	BERYLLIUM COPPER, BRASS	GOLD 1.3 OVER NICKEL 2
OUTER CONTACT	BERYLLIUM COPPER	NPGR
INSULATOR	PTFE	
GASKET	-	
OTHERS PARTS	BRASS	NICKEL 2
-	-	-
-	-	-

Issue : 0940 B

In the effort to improve our products, we reserve the right to make changes judged to be necessary.



**STRAIGHT FLOATING SNAP-IN MOUNT JACK**

**R128.238.701**

**CRIMP TYPE CABLE 5/50 DTR**

Series : **BMA**

**PACKAGING**

Standard	Unit	Other
<b>100</b>	<b>'W' option</b>	<b>Contact us</b>

**SPECIFICATION**

**ELECTRICAL CHARACTERISTICS**

Impedance		<b>50</b> Ω
Frequency		<b>0-12.4</b> GHz
VSWR	<b>1.15</b> +	<b>0,0100</b> x F(GHz) Maxi
Insertion loss		<b>0.03</b> √F(GHz) dB Maxi
RF leakage	- (	<b>70</b> - F(GHz)) dB Maxi
Voltage rating		<b>350</b> Veff Maxi
Dielectric withstanding voltage		<b>1000</b> Veff mini
Insulation resistance		<b>5000</b> MΩ mini

**CABLE ASSEMBLY**

Stripping	a	b	c	d	e	f
mm	2,10	6,60	8,70	0,00	6,70	0,00

Assembly instruction : **Crimp 01**

Recommended cable(s)

RG 142  
RG 142 FTX  
KX 23  
RG 400  
RG 223

Characteristics indicated on this data sheet are those that can be achieved with the highest performance cable. Intrinsic limitations of the cable may diminish the performance of the assembly

Cable retention

- pull off **220** N mini  
- torque **NA** N.cm

**MECHANICAL CHARACTERISTICS**

Center contact retention		
Axial force – Mating end	<b>27</b>	N mini
Axial force – Opposite end	<b>27</b>	N mini
Torque	<b>NA</b>	N.cm mini

**TOOLING**

Part Number	Description	Hexagon
R282.223.000	CRIMPING TOOL	5.41
R282.235.011	CRIMPING DIES M22520/5-11	5.41
R282.293.000	CRIMPING TOOL M22520/5-01	

Recommended torque		
Mating	<b>NA</b>	N.cm
Panel nut	<b>NA</b>	N.cm
Clamp nut	<b>NA</b>	N.cm
A/F clamp nut	<b>0,0000</b>	mm

Mating life	<b>1000</b>	Cycles mini
Weight	<b>3,2600</b>	g

**ENVIRONMENTAL**

Operating temperature	<b>-55/+165</b>	°C
Hermetic seal	<b>NA</b>	Atm.cm3/s
Panel leakage	<b>NA</b>	

**OTHER CHARACTERISTICS**

Issue : **0940 B**

In the effort to improve our products, we reserve the right to make changes judged to be necessary.

