

STRAIGHT 2 HOLES FLANGE FLOATING JACK

R128.268.717

CRIMP TYPE FOR 5/50 DTR

Series : BMA-COM

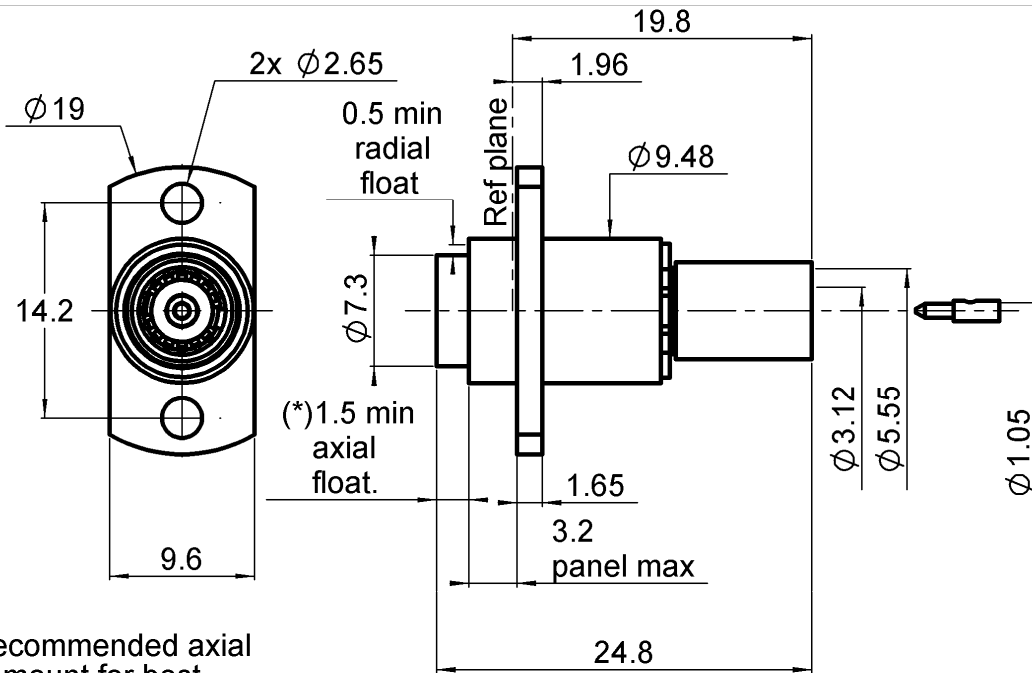

(*) Recommended axial float mount for best electrical performance: 0.51 +/- 0.25 mm (.020" +/- .010)

PANEL DRILLING

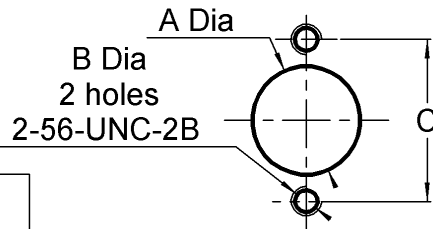

	maxi	mini
A	9.6	9.55
C	14.3	14.1

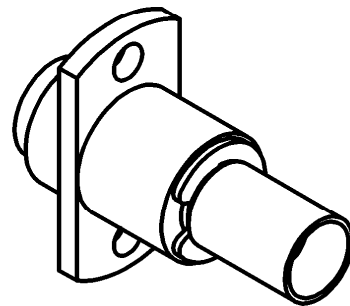
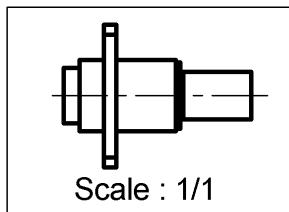

All dimensions are in mm.

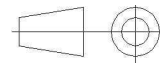

COMPONENTS	MATERIALS	PLATING (μm)
BODY	BRASS	BBR 2
CENTER CONTACT	BERYLLIUM COPPER, BRASS	NPGR
OUTER CONTACT	BERYLLIUM COPPER, BRASS	NPGR
INSULATOR	PTFE	
GASKET	-	
OTHERS PARTS	BRASS	BBR 2
-	-	-
-	-	-

Issue : 0903 B

In the effort to improve our products, we reserve the right to make changes judged to be necessary.



STRAIGHT 2 HOLES FLANGE FLOATING JACK

R128.268.717

CRIMP TYPE FOR 5/50 DTR

Series : **BMA-COM**

PACKAGING

Standard	Unit	Other
100	'W' option	Contact us

SPECIFICATION

ELECTRICAL CHARACTERISTICS

Impedance		50 Ω
Frequency		0-12.4 GHz
VSWR	1.15 +	0,0100 x F(GHz) Maxi
Insertion loss		0.03 √F(GHz) dB Maxi
RF leakage	- (70 - F(GHz)) dB Maxi
Voltage rating		335 Veff Maxi
Dielectric withstanding voltage		1000 Veff mini
Insulation resistance		5000 MΩ mini

CABLE ASSEMBLY

Stripping	a	b	c	d	e	f
mm	2,10	5,50	7,60	0,00	0,00	0,00

Assembly instruction : **Crimp 01**

Recommended cable(s)
 RG 142
 RG 142 FTX
 KX 23
 RG 400
 RG 223

Characteristics indicated on this data sheet are those that can be achieved with the highest performance cable. Intrinsic limitations of the cable may diminish the performance of the assembly

Cable retention

- pull off **180** N mini
 - torque **NA** N.cm

MECHANICAL CHARACTERISTICS

Center contact retention		
Axial force – Mating end	18	N mini
Axial force – Opposite end	18	N mini
Torque	NA	N.cm mini

Recommended torque		
Mating	NA	N.cm
Panel nut	NA	N.cm
Clamp nut	NA	N.cm
A/F clamp nut	0,0000	mm
Mating life	1000	Cycles mini
Weight	5,4600	g

TOOLING

Part Number	Description	Hexagon
R282.223.000	CRIMPING TOOL	5.41
R282.235.011	CRIMPING DIES M22520/5-11	5.41
R282.293.000	CRIMPING TOOL M22520/5-01	

ENVIRONMENTAL

Operating temperature	-65/+155	° C
Hermetic seal	NA	Atm.cm3/s
Panel leakage	NA	

OTHER CHARACTERISTICS

Issue : **0903 B**

In the effort to improve our products, we reserve the right to make changes judged to be necessary.

