

STRAIGHT CLIP-ON FLOATING JACK

R128.296.700

SOLDER TYPE - CABLE .141

Series : BMA

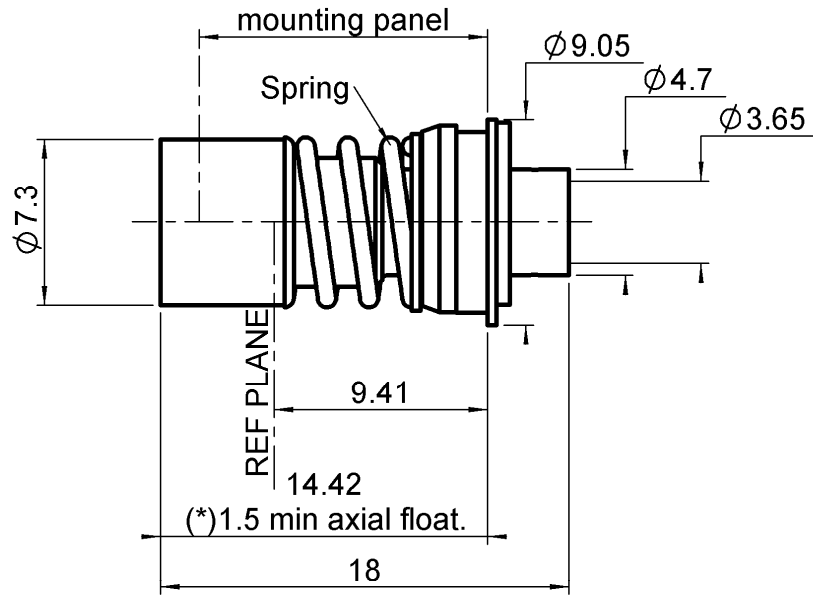

(* Recommended axial float mount for best electrical performance: 0.51 +/- 0.25 mm (.020" +/- .010)

PANEL DRILLING

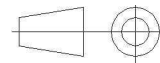
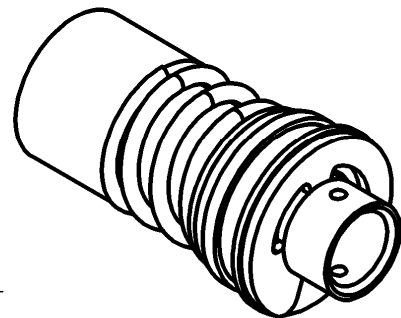
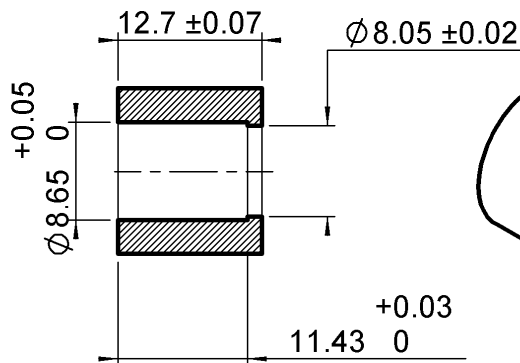
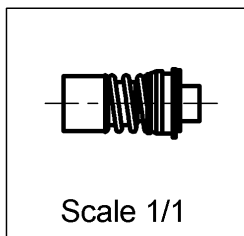

All dimensions are in mm.

COMPONENTS	MATERIALS	PLATING (μm)
BODY	STAINLESS STEEL	GOLD 0.5 OVER NICKEL 2
CENTER CONTACT	BERYLLIUM COPPER	GOLD 1.3 OVER NICKEL 2
OUTER CONTACT	BERYLLIUM COPPER	NPGR
INSULATOR	PTFE	
GASKET	-	
OTHERS PARTS	BERYLLIUM COPPER	NICKEL 2
-	-	-
-	-	-

Issue : 1102 B

In the effort to improve our products, we reserve the right to make changes judged to be necessary.



STRAIGHT CLIP-ON FLOATING JACK

R128.296.700

SOLDER TYPE - CABLE .141

Series : **BMA**

PACKAGING

Standard	Unit	Other
100	'W' option	Contact us

SPECIFICATION

ELECTRICAL CHARACTERISTICS

Impedance		50 Ω
Frequency		0-22 GHz
VSWR	1.05 +	0,0100 x F(GHz) Maxi
Insertion loss		0.03 √F(GHz) dB Maxi
RF leakage	- (90 - F(GHz)) dB Maxi
Voltage rating		500 Veff Maxi
Dielectric withstanding voltage		1500 Veff mini
Insulation resistance		5000 MΩ mini

CABLE ASSEMBLY

Stripping	a	b	c	d	e	f
mm	2,16	0,00	0,00	0,00	0,00	0,00

Assembly instruction :

Recommended cable(s)
RG 402
KS 2

Characteristics indicated on this data sheet are those that can be achieved with the highest performance cable. Intrinsic limitations of the cable may diminish the performance of the assembly

Cable retention

- pull off **272** N mini
- torque **NA** N.cm

MECHANICAL CHARACTERISTICS

Center contact retention		
Axial force – Mating end	27	N mini
Axial force – Opposite end	27	N mini
Torque	NA	N.cm mini

TOOLING

Part Number	Description	Hexagon
.	.	.
R282.053.000	STRIPPING TOOL	
R282.740.000	SOLDERING MOUNTING	
R282.066.000	POINTER GAUGE	
R282.860.130	SOLDER POSITIONER BMA	

Recommended torque		
Mating	NA	N.cm
Panel nut	NA	N.cm
Clamp nut	NA	N.cm
A/F clamp nut	0,0000	mm

Mating life	1000	Cycles mini
Weight	3,0100	g

OTHER CHARACTERISTICS

* Mated with waterproof male connector

It is recommended to use a service loop to facilitate the float features of the connector

ENVIRONMENTAL

Operating temperature	-65/+165	° C
Hermetic seal	NA	Atm.cm3/s
Panel leakage	*IP54	

Issue : **1102 B**

In the effort to improve our products, we reserve the right to make changes judged to be necessary.

