

RIGHT ANGLE 2 HOLES FLANGE FLOATING JACK

R128.360.701

SOLDER TYPE CABLE .085

Series : BMA

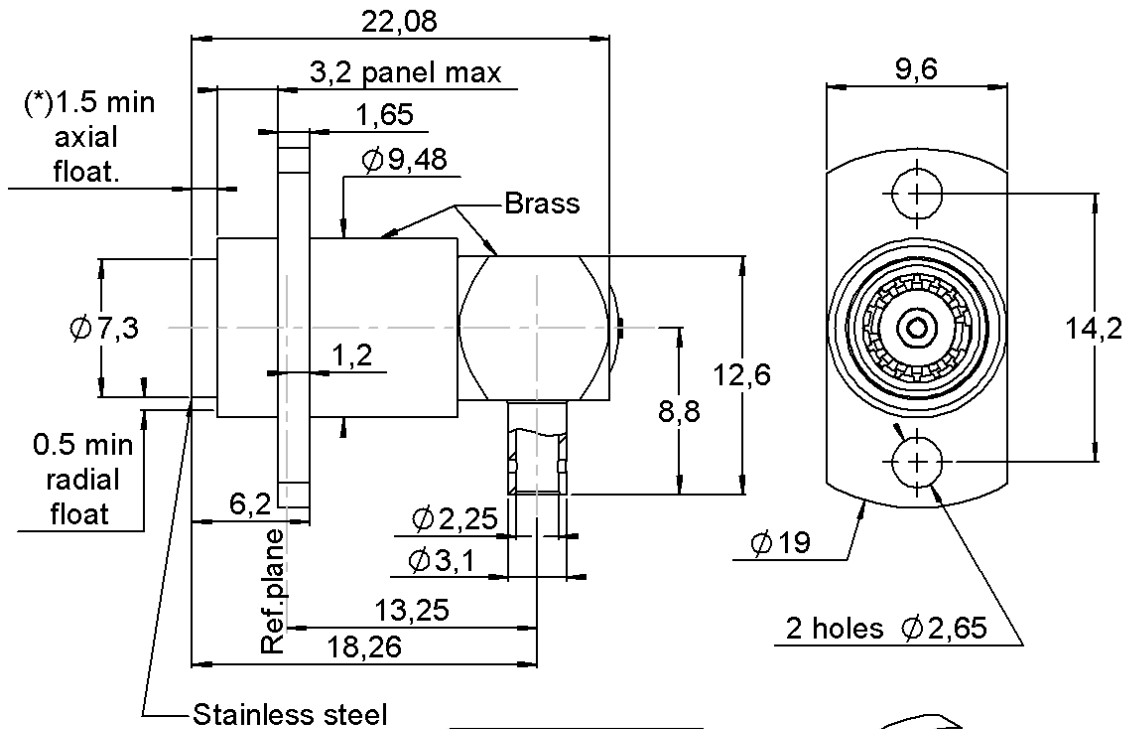

(*) Recommended axial float mount for best electrical performance: 0.51 +/- 0.25 mm (.020" +/- .010)

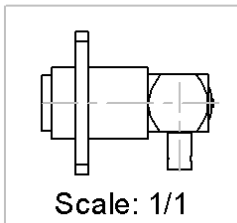

PANEL DRILLING

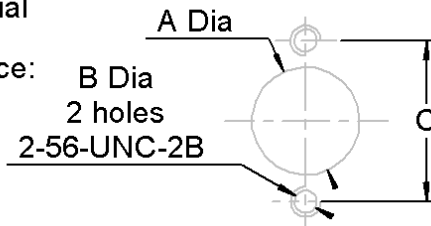
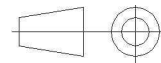
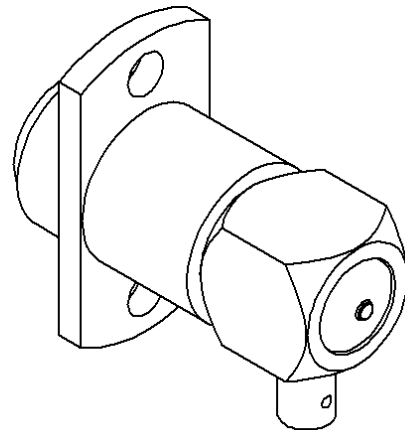

Table générale		
	maxi	mini
A	9.6	9.55
C	14.3	14.1



All dimensions are in mm.

COMPONENTS	MATERIALS	PLATING (µm)
BODY	STAINLESS STEEL + BRASS	GOLD , PASSIVATED
CENTER CONTACT	BERYLLIUM COPPER, BRASS	GOLD 1.3 OVER NICKEL2
OUTER CONTACT	BERYLLIUM COPPER	NPGR
INSULATOR	PTFE	
GASKET	-	
OTHERS PARTS	BRASS	NICKEL, GOLD
-	-	-
-	-	-

Issue : 1408 C

In the effort to improve our products, we reserve the right to make changes judged to be necessary.



RIGHT ANGLE 2 HOLES FLANGE FLOATING JACK

R128.360.701

SOLDER TYPE CABLE .085

Series : **BMA**

PACKAGING

Standard	Unit	Other
100	'W' option	Contact us

SPECIFICATION

ELECTRICAL CHARACTERISTICS

Impedance		50 Ω
Frequency		0-12.4 GHz
VSWR	1.15 +	0,0250 x F(GHz) Maxi
Insertion loss		0.07 √F(GHz) dB Maxi
RF leakage	- (80 - F(GHz)) dB Maxi
Voltage rating		350 Veff Maxi
Dielectric withstanding voltage		1000 Veff mini
Insulation resistance		5000 MΩ mini

CABLE ASSEMBLY

Stripping	a	b	c	d	e	f
mm	4,30	1,40	0,00	0,00	0,00	0,00

Assembly instruction : **NA**

Recommended cable(s)
 RG 405
 KS 1

Characteristics indicated on this data sheet are those that can be achieved with the highest performance cable. Intrinsic limitations of the cable may diminish the performance of the assembly

Cable retention

- pull off **136** N mini
 - torque **NA** N.cm

MECHANICAL CHARACTERISTICS

Center contact retention		
Axial force – Mating end	27	N mini
Axial force – Opposite end	27	N mini
Torque	NA	N.cm mini

Recommended torque		
Mating	NA	N.cm
Panel nut	NA	N.cm
Clamp nut	NA	N.cm
A/F clamp nut	0,0000	mm

Mating life	1000	Cycles mini
Weight	7,7100	g

TOOLING

Part Number	Description	Hexagon
R282740000	SOLDERING MOUNTING	

OTHER CHARACTERISTICS

It is recommended to use a service loop to facilitate the float features of the connector

ENVIRONMENTAL

Operating temperature	-65/+150	°C
Hermetic seal	NA	Atm.cm3/s
Panel leakage	NA	

Issue : **1408** **C**

In the effort to improve our products, we reserve the right to make changes judged to be necessary.

