

NON MAGNETIC RIGHT ANGLE PLUG CRIMP TYPE
CABLE 5/50 S-BR

R141.182.177

Series : BNC

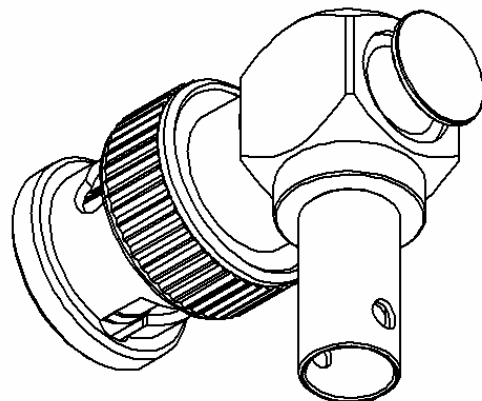
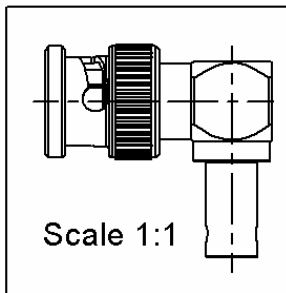
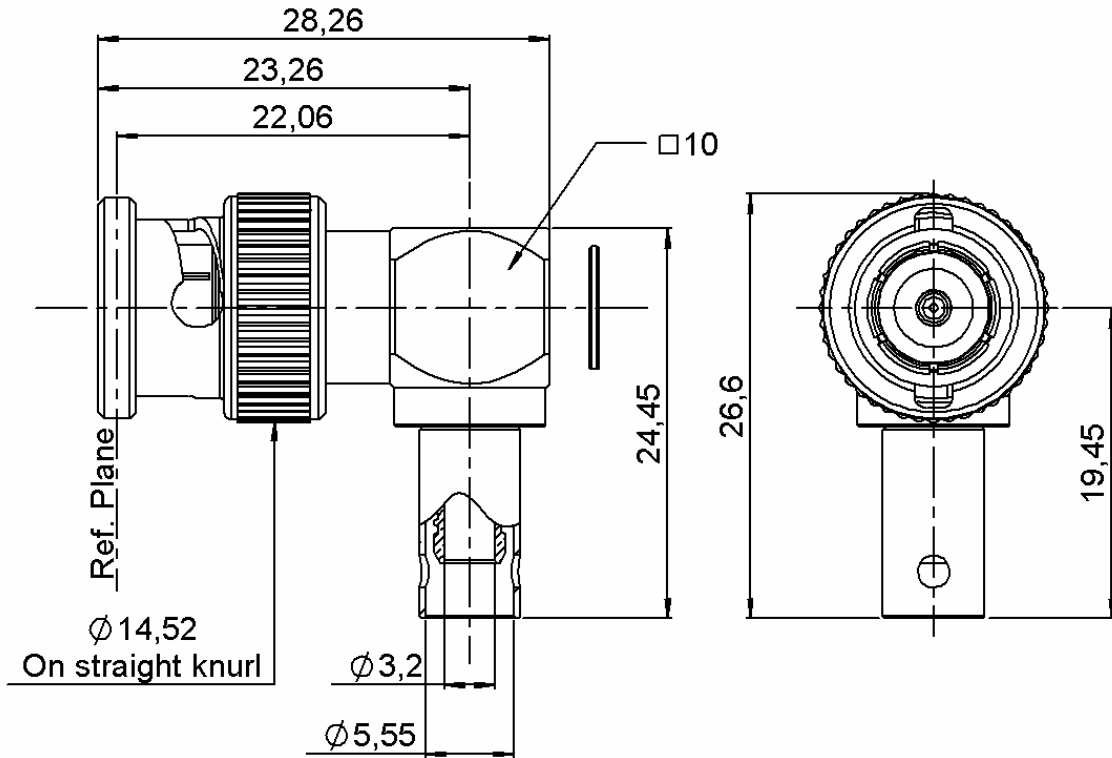

All dimensions are in mm.

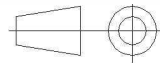

COMPONENTS	MATERIALS	PLATING (µm)
BODY	NON MAGNETIC BRONZE	BBR 2
CENTER CONTACT	NON MAGNETIC BRONZE	GOLD 1.3 OVER COPPER 2.5
OUTER CONTACT	BERYLLIUM COPPER	BBR 2
INSULATOR	PTFE	
GASKET	SILICONE	
OTHERS PARTS	BERYLLIUM COPPER	BBR 2
-	NON MAGNETIC BRONZE	-
-	-	-

Issue : 1143 B

In the effort to improve our products, we reserve the right to make changes judged to be necessary.



**NON MAGNETIC RIGHT ANGLE PLUG CRIMP TYPE
CABLE 5/50 S-BR**

R141.182.177

Series : BNC

PACKAGING

Standard	Unit	Other
100	'W' option	Contact us

SPECIFICATION

ELECTRICAL CHARACTERISTICS

Impedance		50 Ω
Frequency		0-4 GHz
VSWR	1.30 + 0,0000	x F(GHz) Maxi
Insertion loss		0.2 √F(GHz) dB Maxi
RF leakage	- (60 - F(GHz)) dB Maxi
Voltage rating		500 Veff Maxi
Dielectric withstanding voltage		1500 Veff mini
Insulation resistance		5000 MΩ mini

CABLE ASSEMBLY

Stripping	a	b	c	d	e	f
mm	2,00	7,50	16,0	0,00	14,0	0,00

Assembly instruction :

Recommended cable(s)
NON MAGNETIC CABLE

Characteristics indicated on this data sheet are those that can be achieved with the highest performance cable. Intrinsic limitations of the cable may diminish the performance of the assembly

Cable retention

- pull off	TBD N mini
- torque	NA N.cm

MECHANICAL CHARACTERISTICS

Center contact retention		
Axial force – Mating end	18	N mini
Axial force – Opposite end	18	N mini
Torque	NA	N.cm mini

TOOLING

Part Number	Description	Hexagon
.	.	.
R282.235.011	CRIMPING DIES M22520/5-11	5.41
R282.293.000	CRIMPING TOOL M22520/5-01	
R282.223.000	CRIMPING TOOL	5.41

Recommended torque		
Mating		N.cm
Panel nut		N.cm
Clamp nut		N.cm
A/F clamp nut	0,0000	mm
Mating life	500	Cycles mini
Weight	18,2000	g

OTHER CHARACTERISTICS

Distortion of the magnetic field <0.5ppm
at Bo = 1.5 Tesla
Force to engage and disengage : 13.6 N
Coupling mechanism retention axial force : 454 N

ENVIRONMENTAL

Operating temperature	-65/+165	° C
Hermetic seal		Atm.cm3/s
Panel leakage		

Issue : 1143 B

In the effort to improve our products, we reserve the right to make changes judged to be necessary.



RADIALL®