



TECHNICAL DATA

R141.183.000

Issue : 0629 D Page

RIGHT ANGLE CABLE PLUG-CRIMP TYPE
CABLE 5/50 DOUBLE-BRAIDED

Series : BNC

1 / 2

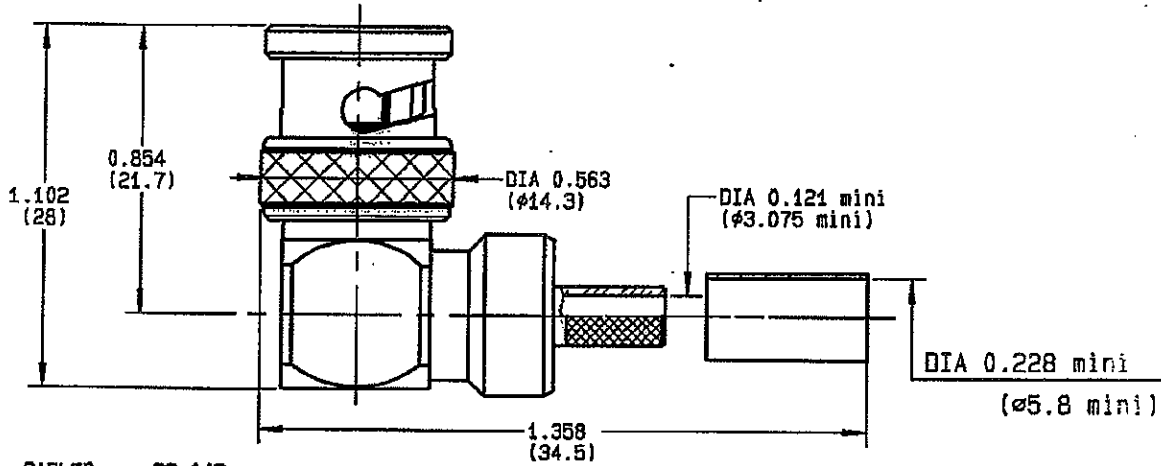

CABLES : RG 142

CHARACTERISTICS

NOMINAL IMPEDANCE	50 Ω
FREQUENCY RANGE	0-4 GHz
TEMPERATURE RATING	-65/+165 °C
VSWR	1.35 + 0 x F(GHz)Maxi
RF INSERTION LOSS	0.175 \sqrt{F} (GHz) dB Maxi
VOLTAGE RATING	500 Vrms Max
DIELECTRIC WITHSTANDING VOLTAGE	1500 Vrms min
INSULATION RESISTANCE	5000 M Ω min
HERMETIC SEAL	- cc/s NA Atm.cm3/s
LEAKAGE (pressurized only)	- psi NA MPa
WEIGHT	0.8571 Oz 24 g

STANDARDISATION

CECC 22120/BNC
CEI 169-8/BNC
MIL STD348-301/BNC
NF C93-564/KBN

CABLE RETENTION	49.39 230	lb min N
CENTER CONTACT RETENTION		
Axial force - mating end	6.06 27	lb min N
Axial force - opposite end	6.06 27	lb min N
Torque (Min)	NA	inch.oz cm.N
RECOMMENDED TORQUES		
Mating	0	inch.lb cm.N
Panel nut	0	inch.lb cm.N
Clamp nut	0	inch.lb cm.N

CONSTRUCTION

CONNECTOR PARTS	MATERIALS	FINISH
BODY	BRASS	NICKEL
OUTER CONTACT	BRASS	NICKEL
CENTER CONTACT	BRASS	GOLD
INSULATOR	PTFE	-
CENTER CONTACT	BERYLLIUM COPPER	GOLD
-	-	-
-	-	-
-	-	-
-	-	-

ISSUE	REVISION No	DESCRIPTION	BY	DATE
9509	94.06.005	Added harpoon on centre contact	BERTHET	19-01-95
9417	93.12.005	Changed ferrule + half-body	BERTHET	26-04-94

Initiated on 02/04/84

The information given here is subject to change without notice. Design changes may be in order to improve the product.



Approval by -

PERRIN

DEP84.R141.000



R141.183.000

Issue : 0629 D

Page

2 / 2

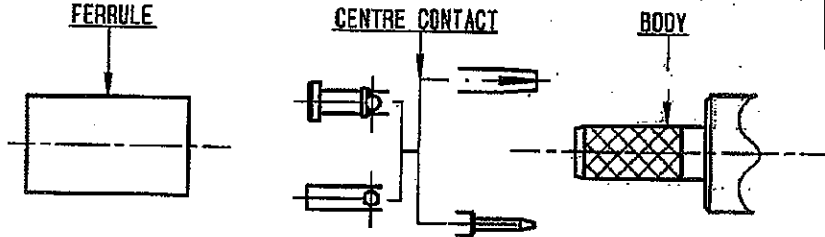

①

Slide onto the cable the ferrule
Strip the cable .

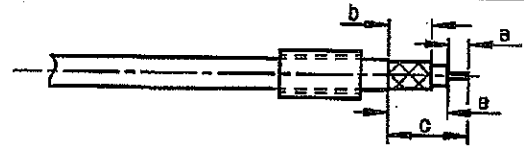

Stripping	a	b	c	d	e
inch	0.157	0.335	0.591	0	0.433
mm	4	8.5	15	-	11

②

Slide on centre contact until it
bottoms against cable dielectrique .
Solder or crimp centre contact .
Crimping tool : R282 223 000 (Hex. : .068)
or R282 293 000 (M22520/5-01)
+ dies R282 235 011 (M22520/5-11) .

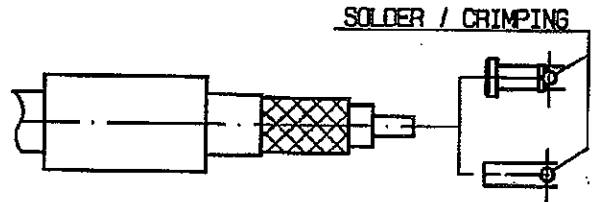

③

Fan the braid .
Slide cable into the body until
bottoms against insulator .
Slide ferrule over the braid .
(In direction F)

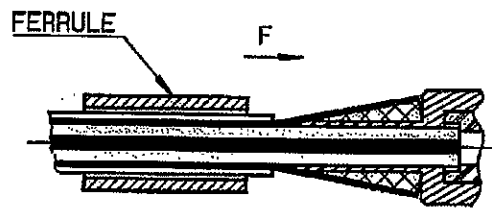

④

Crimp the ferrule with crimping tool
R 282 223 000 (Hex. : .213) or
crimping tool R282 293 000 (M22520/5-01)
+ dies R282 235 011 (M22520/5-11)
Cut the excess of braid .

