

PAGE 1/2	ISSUE 1422A	SERIES TNC-18	PART NUMBER R143068L60
----------	-------------	---------------	------------------------

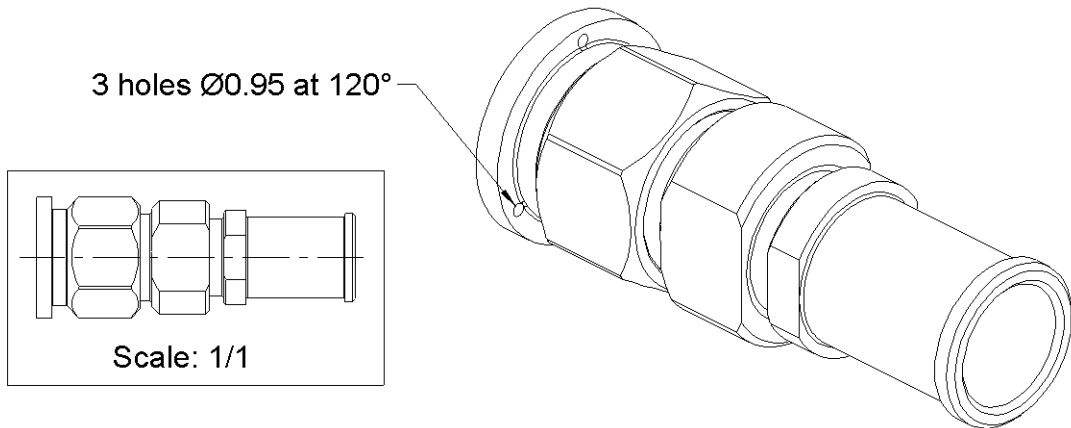

All dimensions are in mm.

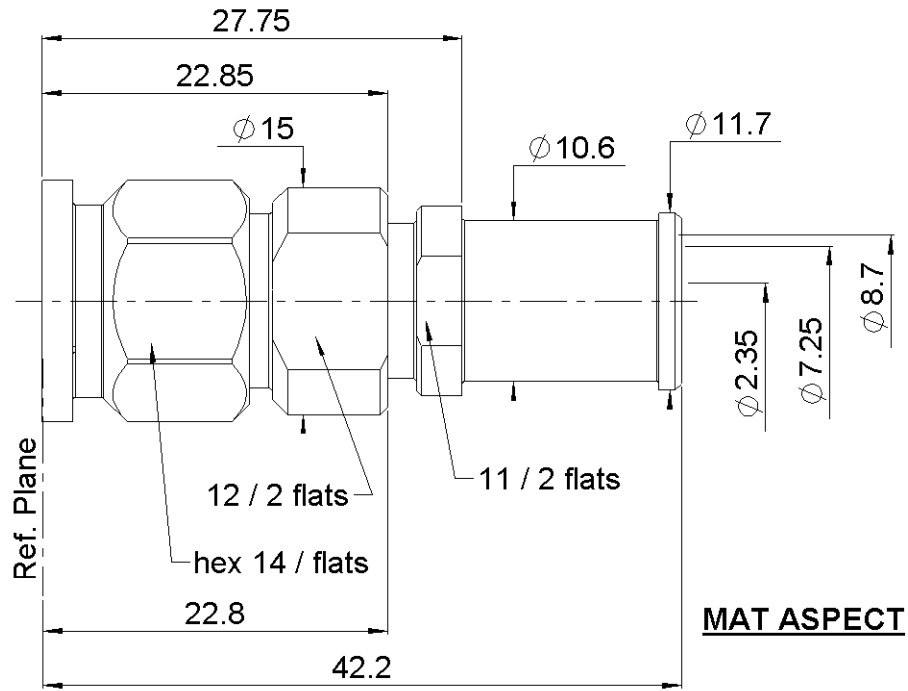
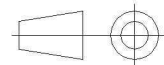

COMPONENTS	MATERIALS	PLATING ( $\mu\text{m}$ )
Body	<b>STAINLESS STEEL (316L)</b>	-
Center contact	<b>BRASS</b>	<b>GOLD 2.5 OVER NICKEL 2</b>
Outer contact	-	-
Insulator	<b>PTFE</b>	-
Gasket	<b>FLUOROSILICON</b>	-
Others parts	<b>STAINLESS STEEL, BRASS</b>	<b>GOLD , PASSIVATED</b>
-	-	-
-	-	-

PAGE <b>2/2</b>	ISSUE <b>1422A</b>	SERIES <b>TNC-18</b>	PART NUMBER <b>R143068L60</b>
-----------------	--------------------	----------------------	-------------------------------

### PACKAGING

Standard	Unit	Other
<b>25</b>	<b>Contact us</b>	<b>Contact us</b>

### ELECTRICAL CHARACTERISTICS

Impedance	<b>50</b>	$\Omega$
Frequency	<b>0-18</b>	GHz
VSWR	<b>1.15 + 0,0000</b>	x F(GHz) Maxi
Insertion loss	<b>0.06</b>	$\sqrt{F}$ (GHz) dB Maxi
RF leakage	- ( <b>90</b> )	- F(GHz)) dB Maxi
Voltage rating	<b>500</b>	Veff Maxi
Dielectric withstanding voltage	<b>1500</b>	Veff mini
Insulation resistance	<b>5000</b>	M $\Omega$ mini

### MECHANICAL CHARACTERISTICS

Center contact retention		
Axial force – Mating End	<b>27</b>	N mini
Axial force – Opposite end	<b>27</b>	N mini
Torque	<b>NA</b>	N.cm mini
Recommended torque		
Mating	<b>330</b>	N.cm
Panel nut		N.cm
Clamp nut	<b>300</b>	N.cm
A/F clamp nut	<b>11,0000</b>	mm
Mating life	<b>500</b>	Cycles mini
Weight	<b>24,1500</b>	g

### ENVIRONMENTAL

Operating temperature	<b>-65/+165</b>	$^{\circ}\text{C}$
Hermetic seal		Atm.cm3/s
Panel leakage	<b>*IP67</b>	

### SPECIFICATION

### CABLE ASSEMBLY

Stripping	a	b	c	d	e	f
mm	<b>3</b>	<b>13,5</b>	<b>0</b>	<b>0</b>	<b>0</b>	<b>0</b>

Assembly instruction: **SHF Solder 01**

Recommended cable(s)

**SHF8M**  
**SHF8**

Characteristics indicated on this data sheet are those that can be achieved with the highest performance cable. Intrinsic limitations of the cable may diminish the performance of the assembly

Cable retention

- pull off	<b>TBD</b>	N mini
- torque	<b>NA</b>	N.cm

### TOOLING

Part Number	Description	Hexagon
R282740043	CONNECTORS SOLDERING MOUNTING KIT	
R282862030	SOLDER GAUGE THCK 0.30	

### OTHER CHARACTERISTICS

**When mated to female connector**