

**RIGHT ANGLE PLUG CRIMP TYPE**

**R143.181.000**

**CABLE 2.6/50 S**

Series : TNC

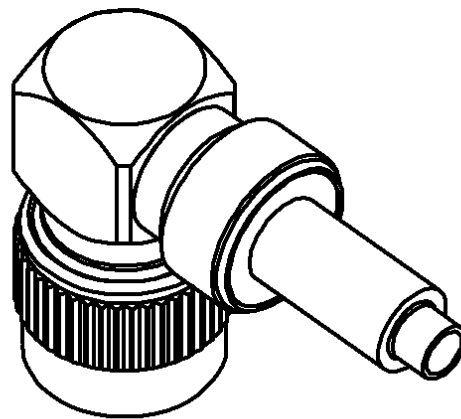
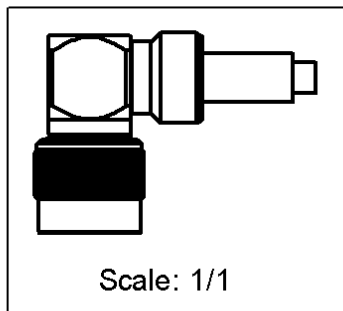
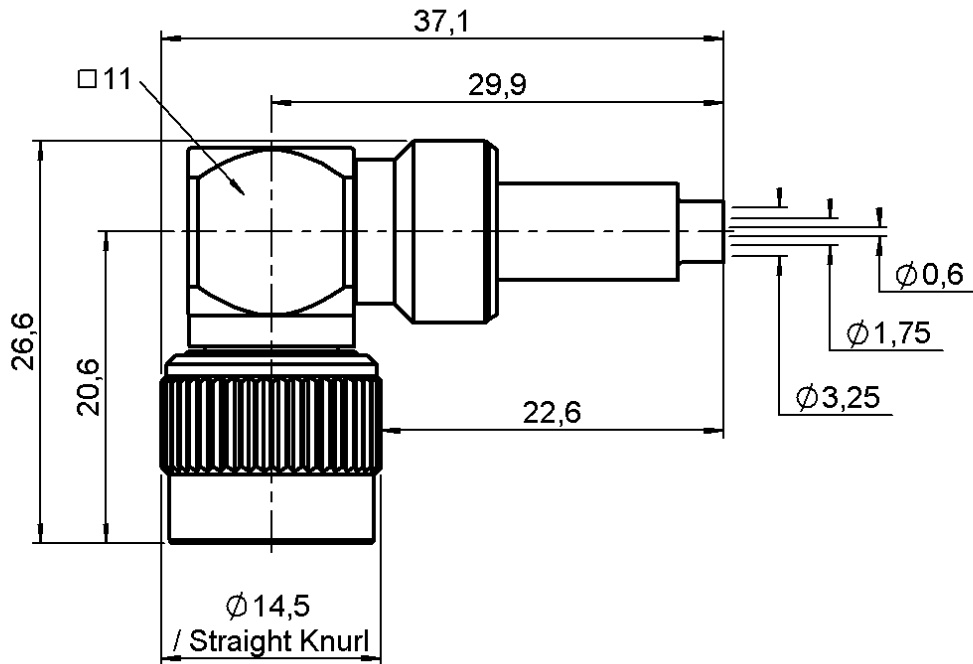

All dimensions are in mm.



COMPONENTS	MATERIALS	PLATINGS (µm)
BODY	BRASS	NICKEL 2
CENTER CONTACT	BRASS	GOLD 0.5 OVER NICKEL 2
OUTER CONTACT	-	-
INSULATOR	PTFE	-
GASKET	SILICONE RUBBER	-
OTHERS PARTS	BRASS	NICKEL 2
-	-	-
-	-	-

Issue : 0245 B

In the effort to improve our products, we reserve the right to make changes judged to be necessary.



**RIGHT ANGLE PLUG CRIMP TYPE**

**R143.181.000**

**CABLE 2.6/50 S**

Series : TNC

**PACKAGING**

Standard	Unit	Other
<b>1</b>	-	<b>Contact us</b>

**SPECIFICATION**

**ELECTRICAL CHARACTERISTICS**

Impedance		<b>50</b> Ω
Frequency		<b>0-11</b> GHz
VSWR	<b>1.40</b> +	<b>0.000</b> x F(GHz) Maxi
Insertion loss		<b>0.07</b> √F(GHz) dB Maxi
RF leakage	- (	<b>57</b> - F(GHz)) dB Maxi
Voltage rating		<b>335</b> Veff Maxi
Dielectric withstanding voltage		<b>1000</b> Veff mini
Insulation resistance		<b>5000</b> MΩ mini

**CABLE ASSEMBLY**

Stripping	a	b	c	d	e	f
mm	4.00	14.0	18.5	0.00	14.5	0.00

Assembly instruction : **Crimp 03**

Recommended cable(s)  
 KX 22A  
 RG 188  
 RG 316

Cable retention  
 - pull off **40** N mini  
 - torque **NA** N.cm

**MECHANICAL CHARACTERISTICS**

Center contact retention		
Axial force – Mating end	<b>27</b>	N mini
Axial force – Opposite end	<b>27</b>	N mini
Torque	<b>NA</b>	N.cm mini

**TOOLING**

Part Number	Description	Hexagon
.	.	.
R282.223.000	CRIMPING TOOL	1.73-5.41
R282.235.011	CRIMPING DIES	1.73-5.40
R282.293.000	CRIMPING TOOL	-

Recommended torque		
Mating	<b>NA</b>	N.cm
Panel nut	<b>NA</b>	N.cm
Clamp nut	<b>NA</b>	N.cm
A/F clamp nut	<b>0.000</b>	mm

Mating life	<b>500</b>	Cycles mini
Weight	<b>24.410</b>	g

**OTHERS CHARACTERISTICS**

-

**ENVIRONMENTAL**

Operating temperature	<b>-65/+165</b>	° C
Hermetic seal	<b>NA</b>	Atm.cm3/s
Panel leakage	<b>NA</b>	

Issue : 0245 B

In the effort to improve our products, we reserve the right to make changes judged to be necessary.

