

RIGHT ANGLE PLUG CRIMP TYPE

R161.194.190

CABLE 8.07/50

Series : N

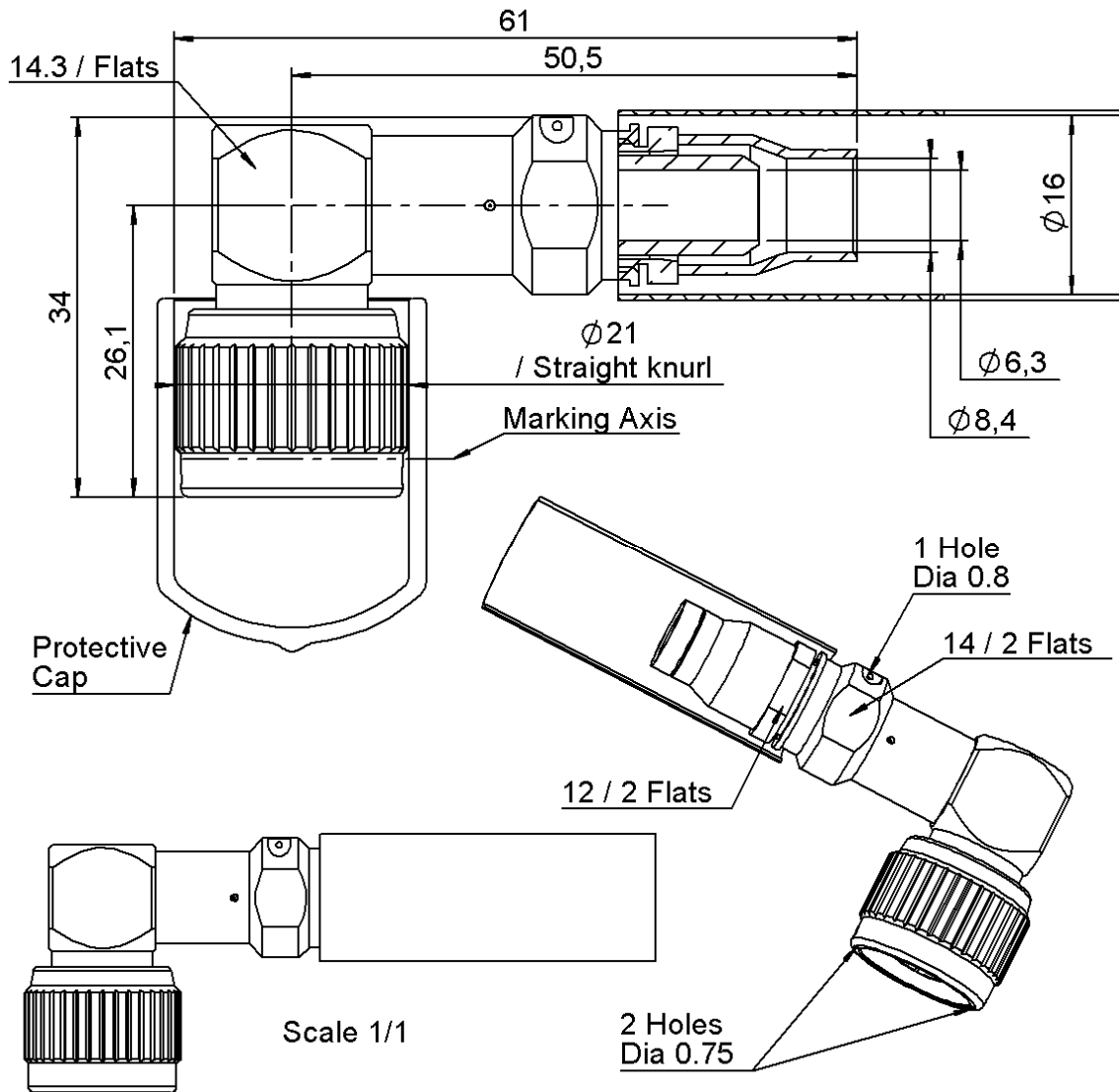

All dimensions are in mm.

| COMPONENTS | MATERIALS | PLATING (µm) |
|----------------|-----------------|-----------------------|
| BODY | BRASS | NICKEL 2 |
| CENTER CONTACT | BRASS | GOLD 1.3 OVER NICKEL2 |
| OUTER CONTACT | BRASS | NICKEL 2 |
| INSULATOR | PTFE | |
| GASKET | SILICONE RUBBER | |
| OTHERS PARTS | BRASS | NICKEL 2 |
| - | - | - |
| - | - | - |

Issue : 1406 B

In the effort to improve our products, we reserve the right to make changes judged to be necessary.



RIGHT ANGLE PLUG CRIMP TYPE

R161.194.190

CABLE 8.07/50

Series : N

PACKAGING

| Standard | Unit | Other |
|----------|------|-------------------|
| 1 | - | Contact us |

SPECIFICATION

**ASNE0462-FC02
QAE 06-02 -**

ELECTRICAL CHARACTERISTICS

| | | |
|---------------------------------|---------------------|--------------------------|
| Impedance | 50 | Ω |
| Frequency | 0-3 | GHz |
| VSWR | 1.2 + 0,0000 | x F(GHz) Maxi |
| Insertion loss | 0.07 | \sqrt{F} (GHz) dB Maxi |
| RF leakage | - (NA) | - F(GHz)) dB Maxi |
| Voltage rating | 1000 | Veff Maxi |
| Dielectric withstanding voltage | 1500 | Veff mini |
| Insulation resistance | 5000 | M Ω mini |

CABLE ASSEMBLY

| Stripping | a | b | c | d | e | f |
|-----------|------|------|------|------|------|------|
| mm | 9,00 | 9,00 | 27,0 | 0,00 | 0,00 | 0,00 |

Assembly instruction :

Recommended cable(s)
ASNE0406-WD
ASNE0692-WN

Characteristics indicated on this data sheet are those that can be achieved with the highest performance cable. Intrinsic limitations of the cable may diminish the performance of the assembly

Cable retention

| | | |
|------------|------------|--------|
| - pull off | 400 | N mini |
| - torque | | N.cm |

MECHANICAL CHARACTERISTICS

| | | |
|----------------------------|-----------|-----------|
| Center contact retention | | |
| Axial force – Mating end | 27 | N mini |
| Axial force – Opposite end | 27 | N mini |
| Torque | NA | N.cm mini |

TOOLING

| Part Number | Description | Hexagon |
|-------------|--|---------------|
| 282247 | CRIMPING DIE M 22520/5-61 | 10.9 |
| 282291 | CRIMPING TOOL M22520/1-01 | 2x4 (loc8) |
| 282997 | POSITIONER FOR TOOL 282.291(M22520/1-13) | Red |
| R282293000 | CRIMPING TOOL M22520/5-01 | |

| | | |
|--------------------|----------------|------|
| Recommended torque | | |
| Mating | NA | N.cm |
| Panel nut | NA | N.cm |
| Clamp nut | 370 | N.cm |
| A/F clamp nut | 12,0000 | mm |

| | | |
|-------------|----------------|-------------|
| Mating life | 500 | Cycles mini |
| Weight | 69,1140 | g |

ENVIRONMENTAL

| | | |
|-----------------------|-----------------|--------------|
| Operating temperature | -65/+165 | $^{\circ}$ C |
| Hermetic seal | NA | Atm.cm3/s |
| Panel leakage | NA | |

OTHER CHARACTERISTICS

Issue : 1406 B

In the effort to improve our products, we reserve the right to make changes judged to be necessary.

