

STRAIGHT BULKHEAD JACK FULL CRIMP

R164.329.000

PANEL SEAL CABLE 5/50 S

Series : QN

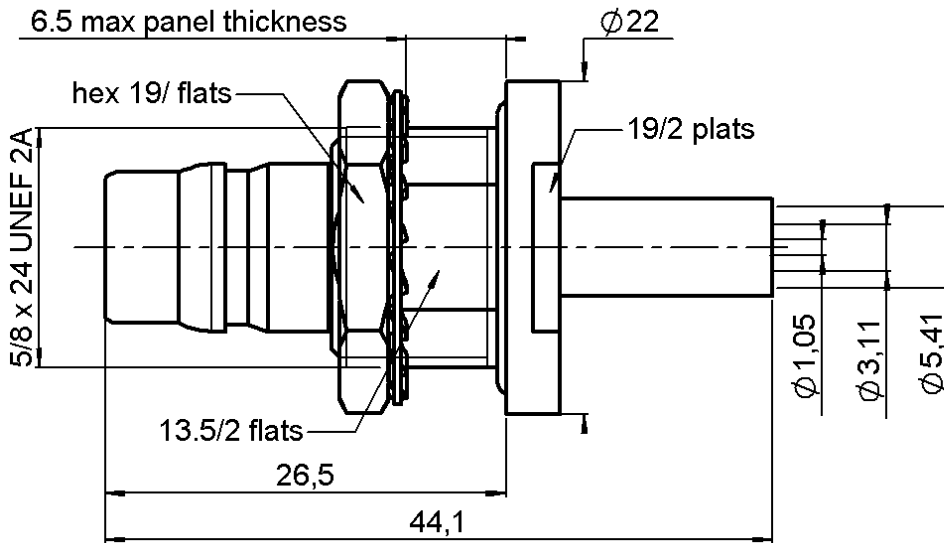

PANEL CUT OUT

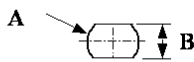

		mm	
		Maxi	mini
A		16.3	16
B		13.9	13.6

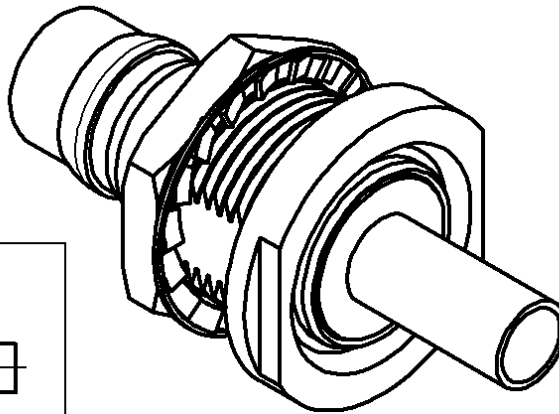
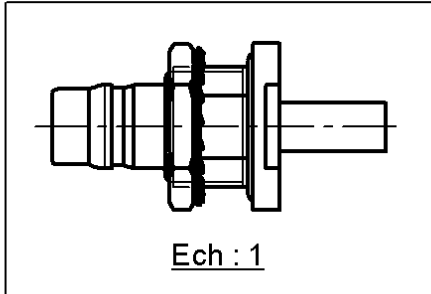

All dimensions are in mm.

COMPONENTS	MATERIALS	PLATING (µm)
BODY	BRASS	BBR 0.5 OVER SILVER 3
CENTER CONTACT	BERYLLIUM COPPER	PASSIVIERUNG SILBER 5 AUF KUPFLER 0.5
OUTER CONTACT	-	-
INSULATOR	PTFE	-
GASKET	SILICONE RUBBER	-
OTHERS PARTS	BRASS	BBR 2
-	-	-
-	-	-

Issue : 0505 B

In the effort to improve our products, we reserve the right to make changes judged to be necessary.



STRAIGHT BULKHEAD JACK FULL CRIMP

R164.329.000

PANEL SEAL CABLE 5/50 S

Series : QN

PACKAGING

Standard	Unit	Other
50	'W' option	Contact us

SPECIFICATION

ELECTRICAL CHARACTERISTICS

Impedance		50 Ω
Frequency		0-6* GHz
VSWR	1.05 +	0,0250 x F(GHz) Maxi
Insertion loss		0.048 √F(GHz) dB Maxi
RF leakage	- (** - F(GHz)) dB Maxi
Voltage rating		850 Veff Maxi
Dielectric withstanding voltage		1500 Veff mini
Insulation resistance		5000 MΩ mini

CABLE ASSEMBLY

Stripping	a	b	c	d	e	f
mm	4,50	8,00	15,0	0,00	10,5	0,00

Assembly instruction : **Crimp 02**

Recommended cable(s)
 BSSM 742
 KX 15
 RG 141
 ECO 142
 RG 58

Characteristics indicated on this data sheet are those that can be achieved with the highest performance cable. Intrinsic limitations of the cable may diminish the performance of the assembly

Cable retention

- pull off **90** N mini
 - torque **NA** N.cm

MECHANICAL CHARACTERISTICS

Center contact retention		
Axial force – Mating end	27	N mini
Axial force – Opposite end	27	N mini
Torque	NA	N.cm mini

TOOLING

Part Number	Description	Hexagon
.	.	.
R282.223.000	CRIMPING TOOL	1.73 - 5.41
R282.235.011	CRIMPING DIES	1.73 - 5.41
R282.293.000	CRIMPING TOOL	-

Recommended torque		
Mating	NA	N.cm
Panel nut	500	N.cm
Clamp nut	NA	N.cm
A/F clamp nut	19,0000	mm

Mating life	100	Cycles mini
Weight	34,0850	g

OTHER CHARACTERISTICS

* usable 0-11GHz
 ** Connector only : -90dB min DC<F<3GHz
 -80dB min 3<F<6GHz

ENVIRONMENTAL

Operating temperature	-55/+125	° C
Hermetic seal	NA	Atm.cm3/s
Panel leakage	RUISS	

Issue : 0505 B

In the effort to improve our products, we reserve the right to make changes judged to be necessary.

