

**17.5 SQUARE FLANGE RECEPTACLE  
WITH CYLINDRIQUE CONTACT PANEL SEAL**

**R164.418.320**

Series : QN

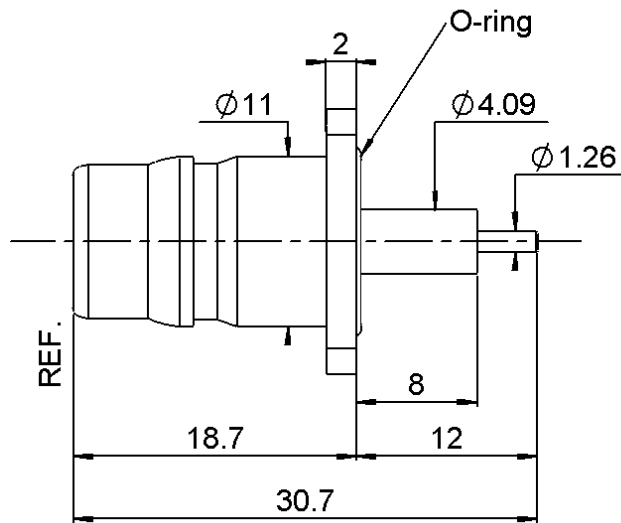
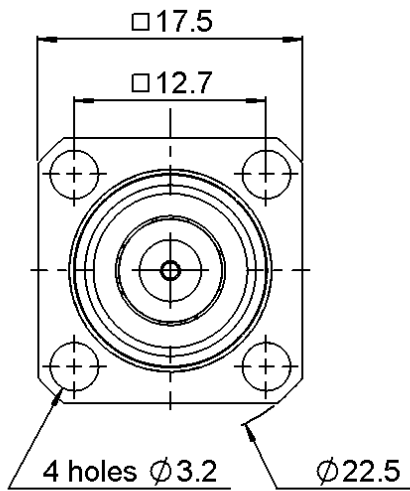

**PANEL CUT OUT**

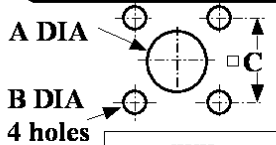

	mm	
	Maxi	mini
A	7.85	7.95
B	3.4	3.3
C	12.75	12.65

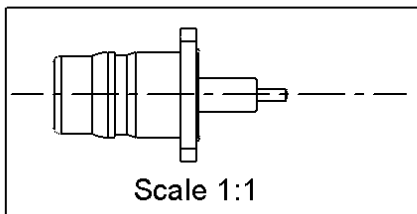
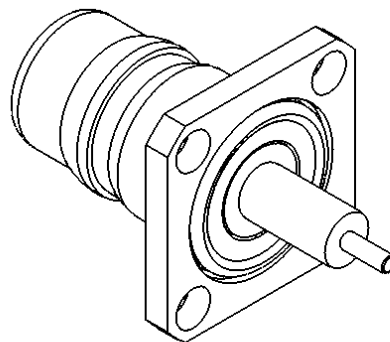

All dimensions are in mm.



COMPONENTS	MATERIALS	PLATING (µm)
BODY	BRASS	BBR 0.5 OVER SILVER 3
CENTER CONTACT	BERYLLIUM COPPER	GOLD 1.3 OVER COPPER 2.5
OUTER CONTACT	-	
INSULATOR	PTFE	
GASKET	SILICONE RUBBER	
OTHERS PARTS	-	
-	-	
-	-	

Issue : 0623 A

In the effort to improve our products, we reserve the right to make changes judged to be necessary.



**17.5 SQUARE FLANGE RECEPTACLE  
WITH CYLINDRIQUE CONTACT PANEL SEAL**

**R164.418.320**

Series : QN

**PACKAGING**

**SPECIFICATION**

Standard	Unit	Other
<b>50</b>	<b>'W' option</b>	<b>Contact us</b>

**ELECTRICAL CHARACTERISTICS**

Impedance	<b>50</b>	$\Omega$
Frequency	<b>0-6</b>	GHz
VSWR	<b>1.05 + 0,0300</b>	x F(GHz) Maxi
Insertion loss	<b>0.048</b>	$\sqrt{F}$ (GHz) dB Maxi
RF leakage	- ( <b>90</b> )	- F(GHz)) dB Maxi
Voltage rating	<b>1000</b>	Veff Maxi
Dielectric withstanding voltage	<b>2000</b>	Veff mini
Insulation resistance	<b>5000</b>	M $\Omega$ mini

**ENVIRONMENTAL**

Operating temperature	<b>-55/+125</b>	$^{\circ}$ C
Hermetic seal	<b>NA</b>	Atm.cm3/s
Panel leakage	<b>IP67</b>	

**OTHER CHARACTERISTICS**

Assembly instruction

Others :

Usable 0-11 GHz

RF Leakage: -80dBm

PIM3: -11.2dBm(2 X 20W at 1.8Ghz)

**MECHANICAL CHARACTERISTICS**

Center contact retention		
Axial force – Mating end	<b>18</b>	N mini
Axial force – Opposite end	<b>18</b>	N mini
Torque	<b>2.8</b>	N.cm mini
Recommended torque		
Mating	<b>NA</b>	N.cm
Panel nut	<b>NA</b>	N.cm
Mating life	<b>100</b>	Cycles mini
Weight	<b>12,0600</b>	g

Issue : 0623 A

In the effort to improve our products, we reserve the right to make changes judged to be necessary.



PRELIMINARY