

# CABLE CLAMP TYPE FOR FLEXIBLE CABLE

## Square flange straight jack

CABLE GROUP	5/50	6/75 + 93
PART NUMBER	R 166 256	R 166 262 ●
a Dia.	.220 (5.6)	.255 (6.5)
Assembly code	M02 page 16	

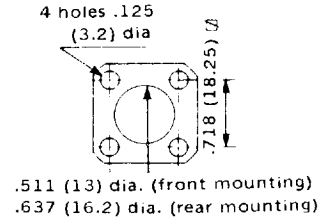
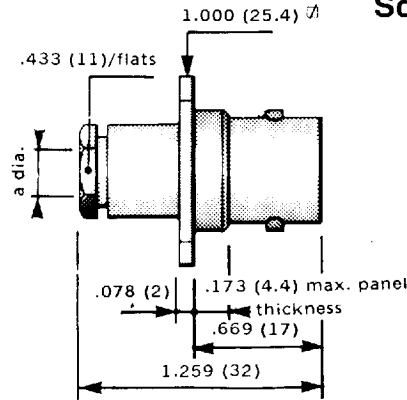

## Square flange straight jack

CABLE GROUP	10 + 11/50	
PART NUMBER	R 166 268	
MIL (UG)	UG 571 A/U	
a Dia.	.440 (11.2)	
Assembly code	M03 page 16	

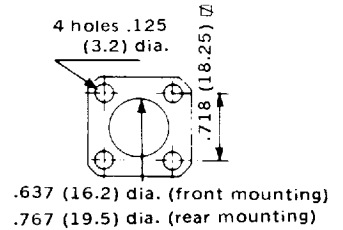
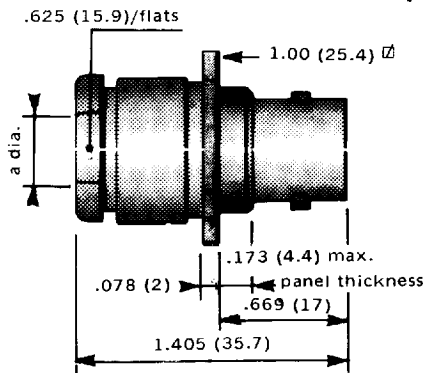

## Bulkhead panel sealed straight jack

CABLE GROUP	5/50	6/75 + 93
PART NUMBER	R 166 326	R 166 328 ●
MIL (UG)	UG 631 A/U	
a Dia.	.220 (5.6)	.255 (6.5)
Assembly code	M02 page 16	

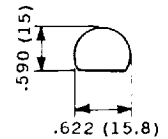
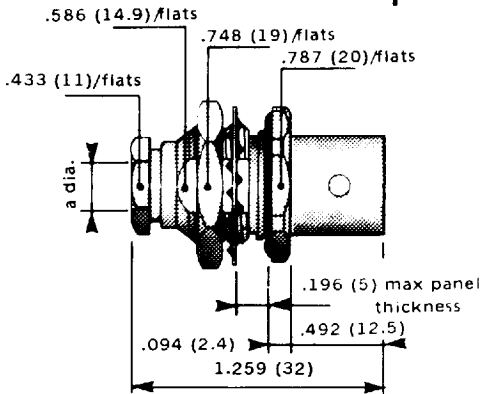

## Bulkhead panel sealed straight jack

CABLE GROUP	10 + 11/50	
PART NUMBER	R 166 332	
MIL (UG)	UG 570 A/U	
a Dia.	.440 (11.2)	
Assembly code	M03 page 16	

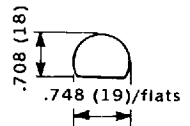
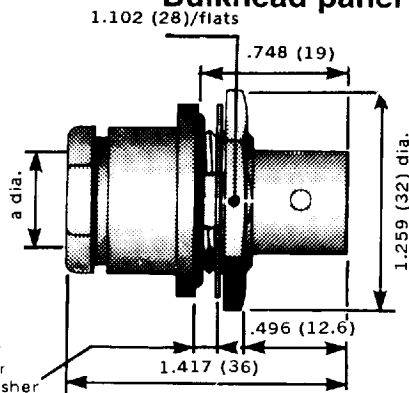

max. panel thickness  
1 with washer  
4 without washer

● Manufactured upon request. Please consult us.